

**Standardtype**

Ventil in Ruhestellung geschlossen-NC. Der erregte Magnet öffnet eine Vorsteuerbohrung und hebt direkt oder unterstützt von der Druckdifferenz den Kolben vom Hauptsitz. Das Ventil schließt durch Federkraft.

**Standard type**

Valve normally closed - NC. When energised, the solenoid will open/free the pilot chamber and the valve will open directly or servo assisted by the pressure differential of the flow medium. The valve closes by spring power.



Steuerungsart: Type of control:	zwangsgesteuert force pilot operated	Metall. Innenteile: Metallic internals:	Messing und Edelstahl 1.4104 Brass and stainless steel (AISI 430F)
Konstruktion: Construction:	Kolbensitzventil Piston design	Dichtung: Sealing:	NBR NBR
Anschluss: Connection:	G1/4-G1, DIN ISO 228 G1/4-G1, DIN ISO 228	Einbaulage: Installation:	nur mit stehendem Magneten actuator only in upright position
Druck: Pressure:	0-40 bar 0-40 bar	Anschlussspannung: Supply voltage:	AC: 24,42,110,230V 50Hz DC: 24,110,205V=
Durchflussmedium: Medium:	neutrale, gasförmige u. flüssige Medien neutral, gaseous and liquid medium	Spannungstoleranz: Voltage tolerance:	+5% / -10% +5% / -10%
Viskosität: Viscosity:	22mm <sup>2</sup> /s 22mm <sup>2</sup> /s	Leistungsaufnahme: Power-consumption:	1702/3702 = 25 Watt 1322/3322 = 30 Watt
Mediumtemperatur: Medium temperature:	-10 bis +80°C -10 up to +80°C	Schutzart: Protection class:	IP65 nach DIN 40050 IP65 according to DIN 40050
Umgebungstemperatur: Ambient temperature:	+35°C +35°C	Einschaltdauer: Duty factor:	100% ED-VDE 0580 100% ED-VDE 0580
Ventilgehäuse: Body material:	../10/.. = Messing / Brass ../08/.. = Edelstahl 1.4581 / St. steel (AISI 316Ti)	Kabelanschluss: Cable connection:	Gerätestecker DIN 43650 / Klemmkasten DIN 43650 - Plug / terminal box

G	Sitz Orifice Ømm	Kv-Wert Flow-rate m <sup>3</sup> /h	Standardtype Standard type P40	max. Druck bei Magnettype max. pressure regarding solenoid type	
				.702	.322
1/4	13	1,8	A3521/1001/....	0-40	-
3/8	13	4,0	A3522/1001/....	0-40	-
1/2	13	4,5	A3523/1001/....	0-40	-
3/4	25	11,5	A3524/1001/....	-	0-40
1	25	13,0	A3525/1001/....	-	0-40

Maßzeichnung Standardausführung  
Dimensional drawing of standard type

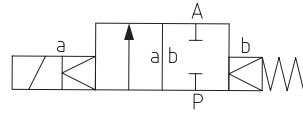
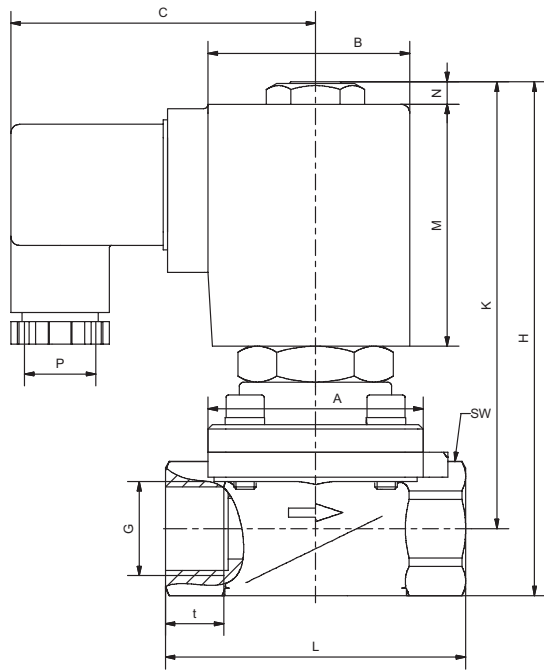

Schaltfunktion/Function:  
in Ruhestellung gesperrt - NC.  
normally closed - NC.

Anschlussplan / Connection diagram

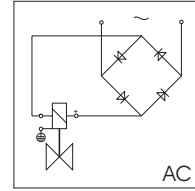
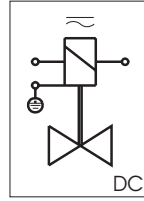

Für Gleichspannung.  
For DC.

Mit vorgeschaltetem Gleichrichter  
für Wechselspannung.  
With rectifier for AC connection.

Erdung oder Schutzschaltung nach Vorschrift des zuständigen EVU.  
Grounding or earthing of the protective circuit in accordance  
with regulations of the responsible electric supply company.

Absicherung entsprechend der Stromaufnahme vorsehen.  
Appropriate protection according to the power-consumption.

Magnet Solenoid	.702	.322
Type	3521-3523	3524-3525
G	1/4 - 1/2	3/4 - 1
A	48	70
B	35x35	Ø63
C	66	76
H	115	162
K	100	136,5
L	67	96
M	50	59
N	10	16
SW	27	41
T	12	16
P	M20x1,5	M20x1,5
kg	0,55	1,4

Ventilloptionen / Valve options

Stromlos geöffnet = NO  
Non energised open = NO

Dichtung = FKM, EPDM, PTFE  
Sealing = FKM, EPDM, PTFE

Stellungsanzeiger (Endschalter ab G3/4 mit Magnet /.322) = EH  
Position indicator (reed contact from G3/4 with solenoid /.322) = EH

Ex-Schutz = Ex II 2G Ex e mb II T4  
Explosion proof = Ex II 2G Ex e mb II T4

Weitere Ex-Schutzarten auf Anfrage  
Further Ex-plosion proof protection classes on demand

Handbetätigung = HA  
Manual override = HA

Öl und fettfrei = OF  
Free of oil and grease = OF (for oxygen applications)

NPT-Anschlussgewinde = NG  
NPT-connection = NG

Stückliste - Parts list

Baureihe / Type A3521-3523

- K1.1 Armatur / Valve body
- K2.1 Deckel / Bonnet
- K2.2 Schraube / Screw
- \*K3.1 Vorsteuersitz / Pilot seat
- \*K3.2 Ventilkolben komplett / Complete valve piston
- \*K3.3 Führungsstern / Guiding insert
- \*K3.4 Vorsteuerspindel / Pilot spindle
- \*K3.5 Kolbenführungsband / Piston ring
- \*K3.6 Vorsteuerspindel / Pilot spindle
- \*K3.7 Mutter / Nut
- \*K3.10 Sicherungsring / Clip
- \*K3.11 Sicherungsring / Clip
- \*K3.15 O-Ring / O-ring
- \*K3.16 O-Ring / O-ring
- \*K3.20 Feder / Spring
- \*K3.21 Feder / Spring
- K5.1 Tubus / Solenoid tube
- K5.2 Scheibe / Washer
- K5.3 Mutter / Nut
- K6.1 Magnet / Solenoid
- K7.1 Stecker / Plug
- K7.2 Dichtung / Seal

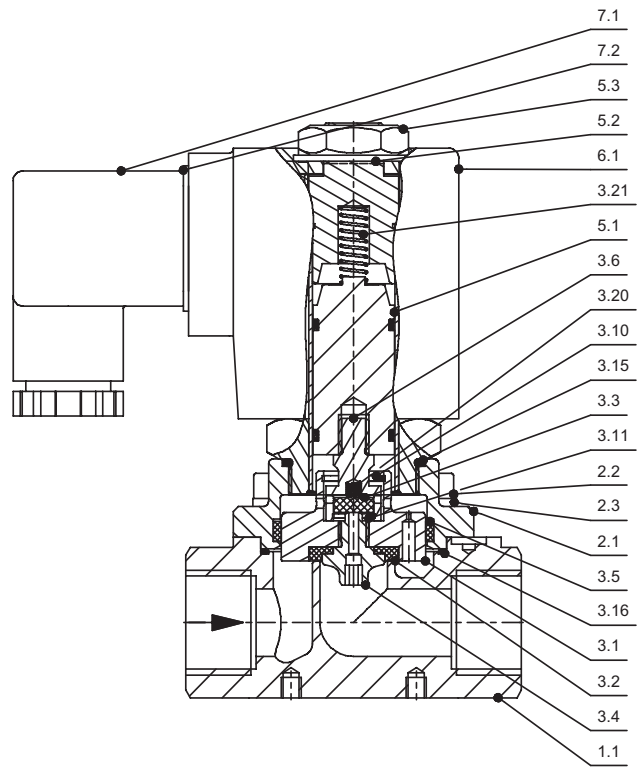

\* = Bestandteil des Ersatzteilpäckchens  
(je nach Ausführung freibleibend)  
\* = Part of the service-set (these specifications  
are without obligation).

Baureihe / Type A3524-3525

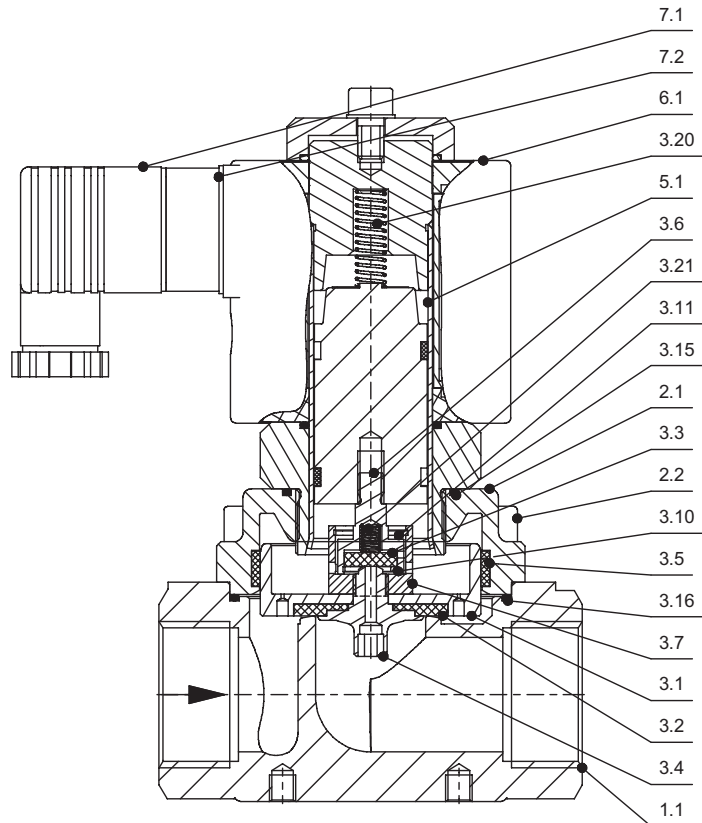

Ventiloptionen / Valve options

Handbetätigung - HA  
Manual operation - HA

- K3.61 Zwischenverschraubung / Screw joint
- K3.62 Spindel / Spindle
- K3.63 Verschraubung / Screw joint
- K3.64 Scheibe / Disk
- K3.65 Nutring / U-ring
- K3.66 O-Ring / O-ring
- K3.67 Handrad / Handwheel
- K3.68 Zyl.-schraube / Cylinder screw
- K3.69 Scheibe / Disk

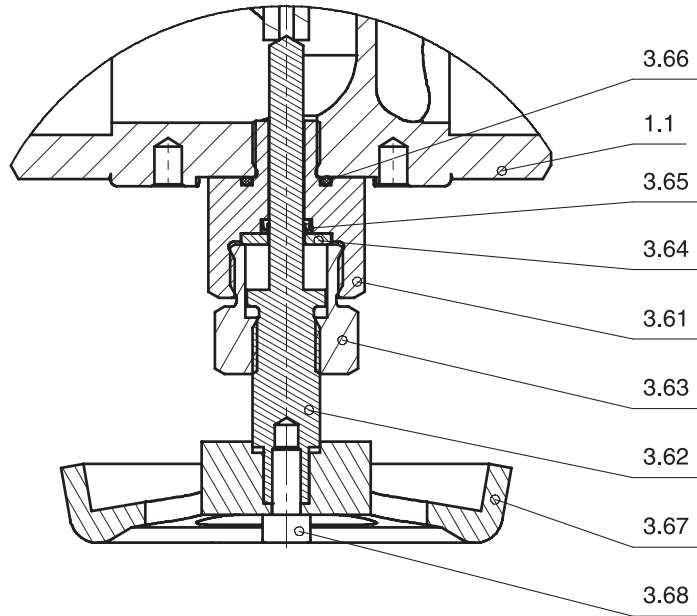

Stellungsanzeiger - EH (ab G1/4 mit Magnet / .322)  
Position indicator - EH (from G1/4 with solenoid / .322)

- K3.33 Feder / Spring
- K3.75 Zwischenverschraubung / Screw joint
- K3.76 Spindel / Spindle
- K3.77 Schutzrohr / Protection tube
- K3.79 O-Ring / O-ring
- K3.82 Senkschraube / Countersunk bolt
- K3.83 Permanentmagnet / Permanent magnet
- K3.84 Klemmring / Clamp ring
- K3.85 Verschraubung / Screw joint
- K3.86 Endschafter / Position indicator
- K3.87 6-kt. Mutter / Hexagon nut
- K5.2 Anker / Plunger
- K5.5 O-Ring / O-ring
- K5.6 Scheibe / Disk

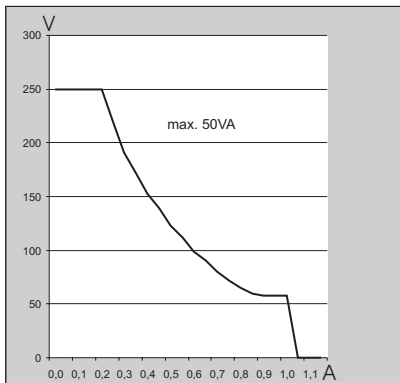
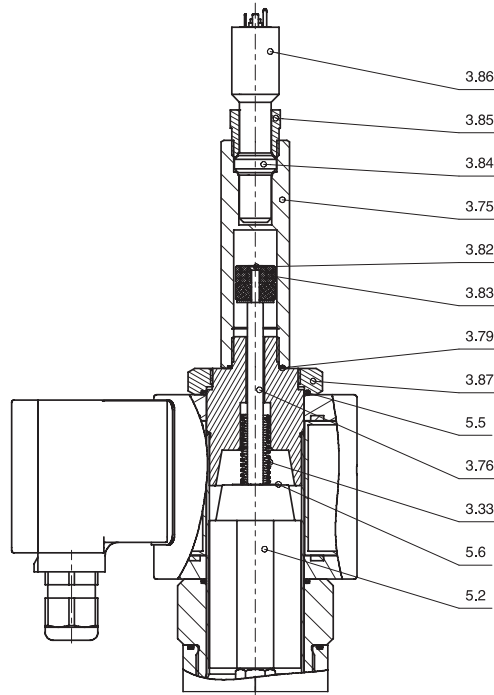

Schaltleistungsdiagramm  
Braking capacity diagram

Anschlussplan /  
Connection diagram

Endschalter / Position indicator

