

Stop Valve 8040

GS 1 series, DN 15 up to DN 150

Pneumatic piston operated stop valve for switching of neutral through to highly aggressive media in process engineering, chemical industry and for plant equipment.

- Space saving wafer-type construction
- Lowest possible weight (especially in larger sizes)
- Low operation noise level
- Control of high differential pressures with small actuators
- Greatly reduced energy consumption rates due to short strokes and low actuating force

Technical Information

Body design	flangeless, wafer-type construction dimensions acc. DIN EN 558-1 series 20 for flanges acc. DIN EN 1092-1 form B more versions see on data-sheet 8040-GS3		
Nominal sizes	DN 15 up to DN 150		
Nominal pressure	PN 40 according DIN 2401 also for flanges PN 10 to PN 25		
Media temperature with metal bonnet	body 1.0619	-10°C up to +350°C	
	body 1.4581	-60°C up to +350°C	
Ambient temperature	body 1.0619	-10°C up to +150°C	
	body 1.4581	-20°C up to +150°C	
Pilot pressure	maximum 10 bar (higher on demand)		
Leakage	disc pair carbon-stainless steel	disc pair SFC	disc pair STN 2
(% of Kvs)	< 0,0001	< 0,0005	< 0,001
IEC 60534-4	IV-S1	IV-S1	IV
EN 12266-1	D	E	E

Kvs-values see data sheet 8001.



Packing tested according to TA-Luft as defined in DIN EN ISO 15848-1 and VDI 2440

Options:

- stainless steel bellows
- electrical position indicator
 - inductive switches
 - contact switches
 - manual operation
- pilot valve
 - 230 V AC
 - 24 V DC
- AS-I control head
- complete stainless steel version
- version free of oil and grease

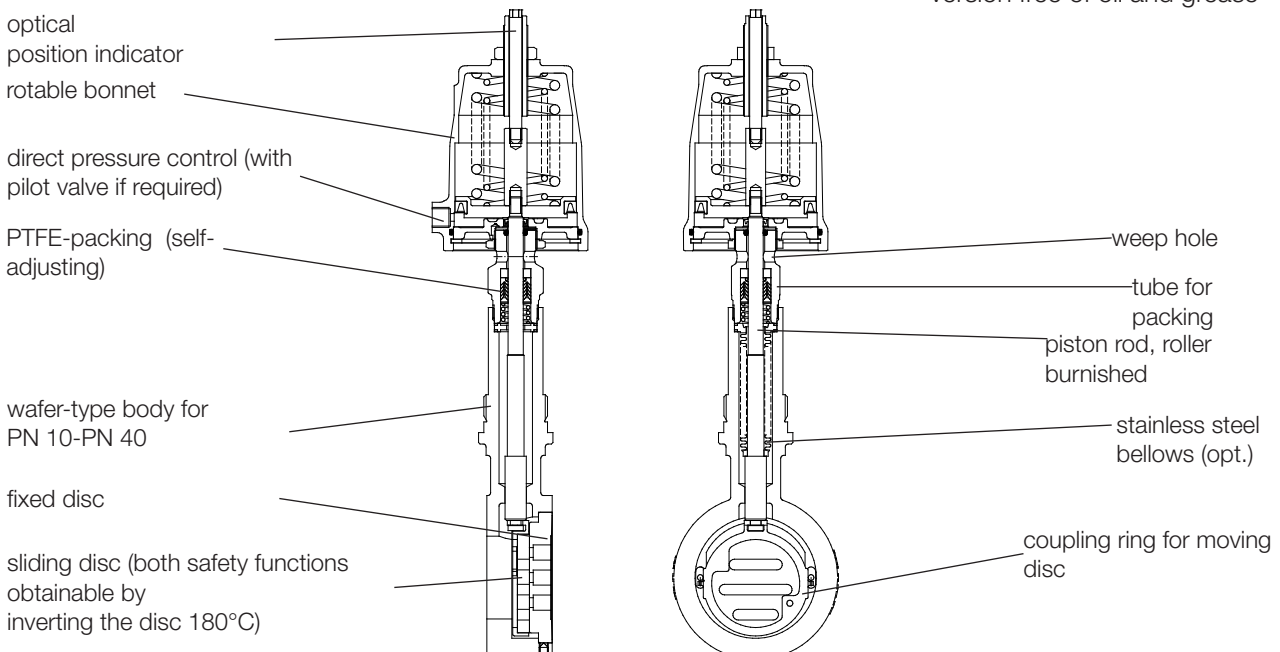

Admissible Differential Pressure (For temperatures of up to 120°C)

For temperatures of 120°C and above: obey application limits !

		Disc pair carbon/SFC-stainless steel coatet	
DN	actuator	max. working pressure (bar)	required pilot pressure (bar)
15	50	33	3,8
20	50	28	3,8
25	50	24	3,8
32	50	19	3,9
40	50	15	4,2
50	50	9	4,8
65	50	8	5
80	50	5	5,3
100	50	3	5,5
125	50	2	5,6
150	50	1,5	5,6
15	80	40	3,1
20	80	40	3,1
25	80	40	3,1
32	80	40	3,2
40	80	40	3,6
50	80	26	4,1
65	80	22	4,3
80	80	14	4,5
100	80	9	4,7
125	80	6	4,8
150	80	4	4,9
15	125	40	1,8
20	125	40	1,8
25	125	40	1,8
32	125	40	1,8
40	125	40	2,1
50	125	38	2,4
65	125	32	2,5
80	125	20	2,6
100	125	13	2,7
125	125	8,5	2,8
150	125	6,5	2,8

		STN2-disc pair	
DN	actuator	max. working pressure (bar)	required pilot pressure (bar)
15	50	23	3,8
20	50	18	4
25	50	13	4,4
32	50	10	4,7
40	50	6,5	4,9
50	50	4	5,4
65	50	3	5,4
80	50	2	5,5
100	50	1	5,6
125	50	--	--
150	50	--	--
15	80	40	3,1
20	80	40	3,3
25	80	36	3,7
32	80	27	4
40	80	18	4,3
50	80	11	4,6
65	80	9	4,7
80	80	5	4,8
100	80	3	4,9
125	80	2	4,9
150	80	1,5	5
15	125	40	1,8
20	125	40	1,9
25	125	40	2,1
32	125	39	2,3
40	125	27	2,5
50	125	16	2,7
65	125	13	2,7
80	125	8	2,8
100	125	5	2,8
125	125	3	2,8
150	125	2	2,8

Special versions for very low pilot pressures or higher working pressures on request.

Applications limits for GS1-Valves

PN 40

DN	Sliding unit: carbon/SFC - stainless steel, coated						Sliding unit: carbon - STN2					
	max. admissible pressures for GS1-valves						max. admissible pressures for GS1-valves					
	100°C	150°C	200°C	250°C	300°C	350°C	100°C	150°C	200°C	250°C	300°C	350°C
15 - 25	40	36	31	28	26	24	40	36	31	28	26	24
32	40	36	31	28	26	24	40	36	31	28	25	22
40	40	36	31	28	26	24	26	25	24	19	16	14
50	40	36	31	28	26	24	40	36	31	28	26	24
65	40	36	31	28	26	24	37	35	31	27	22	19
80	40	36	31	28	26	24	22	20	19	16	13	11
100	24	23	22	19	17	16	13	12	12	9	8	6
125	16	15	14	13	11	10	8	8	7	6	5	4
150	16	16	16	16	14	13	10	10	9	7	6	5

Limitation for SFC-sliding discs: 300°C

Materials

Body	carbon steel 1.0619	stainless steel 1.4581 or 1.4408
Bonnet	brass, chrome coated (actuator Ø50 mm, Ø80 mm) aluminium anodised (actuator Ø125 mm)	
Actuating springs	stainless steel 1.4310 (actuator Ø50 mm, Ø80 mm), spring steel wire C, zinc coated (actuator Ø125 mm)	
Packing	PTFE carbon filled (spring 1.4310)	
Piston rod	stainless steel 1.4571, roller burnished	
Bellows	stainless steel 1.4571	
Fixed disc	stainless steel 1.4571, coated	STN2-disc
Moving disc	standard: special carbon material	SFC-disc STN2-disc
Coupling ring for disc	stainless steel 1.4581	

Ordering Number System

1 2 3 4 5 6 7 8 9 10 11 12 13 14 15 16

8	0	4	0	/			V	B			M			Z		S
---	---	---	---	---	--	--	---	---	--	--	---	--	--	---	--	---

1 - 5 : Please quote all 5 sections
6 - 12: Quote only if required

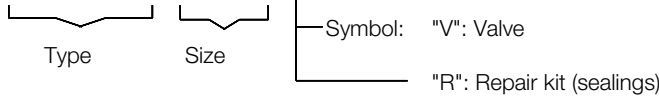

1. Type	2. Connection	3. Body material	4. Safety position	5. Actuator	6. Special versions	7. Springs	8. Stem sealing
B long design (type 8040)	0 flangeless design for flanges acc. DIN 2632-2635 (PN 10-PN 40)	0 carbon steel 1.0619 1 stainless steel 1.4581 or 1.4408 2 carbon steel 1.0619 reduced design 3 stainless steel 1.4581 or 1.4408 reduced design	0 spring closes 1 spring opens 3 double acting	0 piston 50 mm 1 piston 80 mm 2 piston 125 mm	M state, if further sections are quoted	- standard 1 one spring 3 two springs	- PTFE-packing, self adjusting (standard) 1 additional bellows 1.4571

9. Moving disc	10. Fixed plate	11. Kvs-values	12. Characteristic	13. Accessories	14. Switches etc.	15. Pilot valves	16. Specialversions
- carbon material 9 STN2-disc S SFC-disc	- stainless steel 1.4571, coated 1 STN2-disc	- 100 % (Stand.) A red. to 63 % 1 red. to 40 % B red. to 25 % 2 red. to 16 % C red. to 10 % 3 red. to 6,3 % 4 red. to 2,5 % 5 red. to 1 % 6 red. to 20 % 7 red. to 12 % 8 red. to 2 % 9 red. to 0,4%	- linear 1 equal percentage	Z accessories (pos.14 et seq) el. position indicator (cable bushing) N el. position indicator (plug connection)	- without 1 one micro switch 2 two micro switches 3 manual operation 4 stroke limitation 8 two inductive switches P one inductive switch 10-36 VDC PNP	- without 6 pilot valve 230 VAC 7 pilot valve 24 VDC	S further special versions

Ordering examples: 8040/050VB0000M-1 - - - -Z-6

GS-stop valve, DN 50, PN10/40, carbon-steel, spring closes, actuator Ø 50 mm, additional stainless steel bellows 1.4571, sliding disc carbon material, fixed disc stainless steel Kvs-value 100%, flow characteristic linear, pilot valve 230V AC

Dimensions and Weights

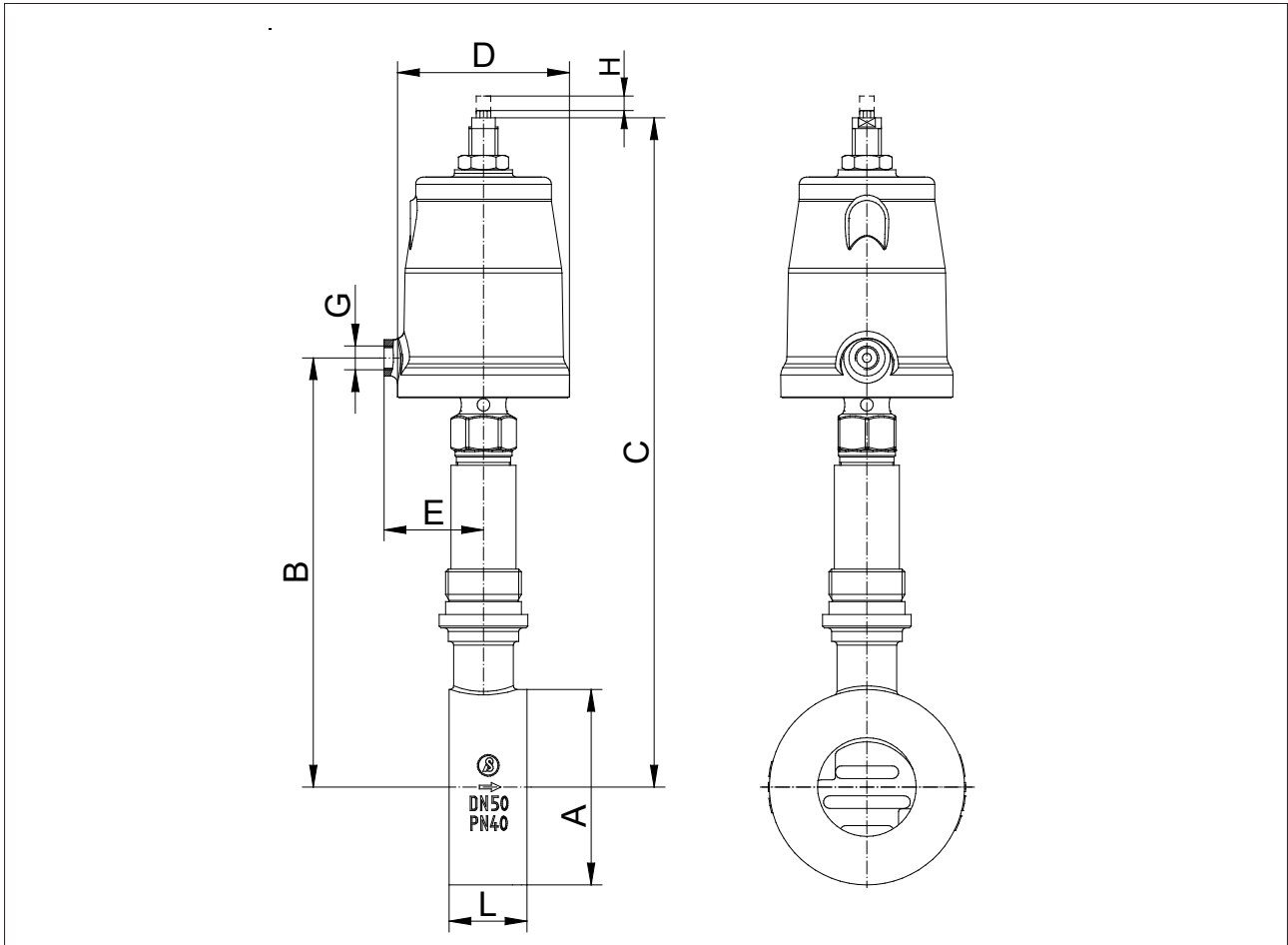

DN	A	B actuator			C max actuator			L	Weight kg actuator			Stroke
		50	80	125	50	80	125		50	80	125	
15	53	205	209	211	302	340	358	33	2,8	5	6,4	6
20	62	210	214	216	307	345	363	33	2,9	5,1	6,5	6
25	72	215	219	222	312	350	369	33	3	5,2	6,6	6
32	82	219	223	226	316	354	373	33	3,1	5,3	6,7	6
40	92	224	228	231	321	359	378	33	3,2	5,4	6,8	6
50	108	234	238	241	333	371	390	43	4,3	6,5	7,9	8
65	127	244	248	250	343	381	399	46	4,8	7	8,4	8
80	142	252	256	258	351	389	407	46	5,5	7,7	9,1	8
100	164	264	268	270	363	401	419	52	6,7	8,9	10	8,5
125	194	277	281	283	376	414	432	56	8,5	11	12	8,5
150	219	292	296	298	391	429	447	56	11	13	14	8,5

Dimension C „reduced design“ shortened by 25,4 mm

Dimensions in mm

Actuator mm	D	G	E
50	62	1/8"	35
80	96	1/4"	55
125	146	1/4"	80

Dimensions in mm