

PHV Singles and Multi Filter Housings

Air / Gas filtration



- Atmospheric pressure range of vent housings
- Available in 1, 3, 5, 8 and 12 round in 10 to 40"
- Range of industry standard connections
- Suitable for group 2 gases



Specifications

Materials of Construction

Housing: 316L/1.4404

Surface Finish

Internal: Mechanical polishing
External: Mechanical mirror polishing

Cartridge Socket: C (226) style
Number of Cartridges: 1, 3, 5, 8, 12

ATEX Regulation: Group 2, CAT 2 Gas & Dust
Fluid GR IIC, Zone 1 & 21

Certification: Supplied as standard with IOMI and vessel inspection certificate

Dimensions

Cartridge number and height	A	B				Weld	C	Handles	ØD	ØE
		Clamp ASME BPE	DIN 11851 Liner Part	DIN 11851 Male part						
01 x 10"	315	43	59	64	70	300	No	88.9	130	
01 x 20"	565	43	59	64	70	550	No	88.9	130	
01 x 30"	815	43	59	64	70	800	No	88.9	130	
01 x 40"	1065	43	59	64	70	1050	No	88.9	130	
03 x 10"	351	97	127	126	143	300	No	219	400	
03 x 20"	601	97	127	126	143	550	Yes	219	400	
03 x 30"	851	97	127	126	143	800	Yes	219	400	
03 x 40"	1101	97	127	126	43	1050	Yes	219	400	
05 x 10"	345	106	133	142	150	300	No	219	400	
05 x 20"	595	106	133	142	150	550	Yes	219	400	
05 x 30"	845	106	133	142	150	800	Yes	219	400	
05 x 40"	1095	106	133	142	150	800	Yes	219	400	
08 x 10"	349	120	147	156	164	300	No	273	440	
08 x 20"	599	120	147	156	164	550	yes	273	440	
08 x 30"	849	120	147	156	164	800	yes	273	440	
08 x 40"	1099	120	147	156	164	1050	yes	273	440	
12 x 10"	346	N.A.	179	192	202	300	No	400	570	
12 x 20"	596	N.A.	179	192	202	550	Yes	400	570	
12 x 30"	846	N.A.	179	192	202	800	Yes	400	570	
12 x 40"	1096	N.A.	179	192	202	1050	Yes	400	570	

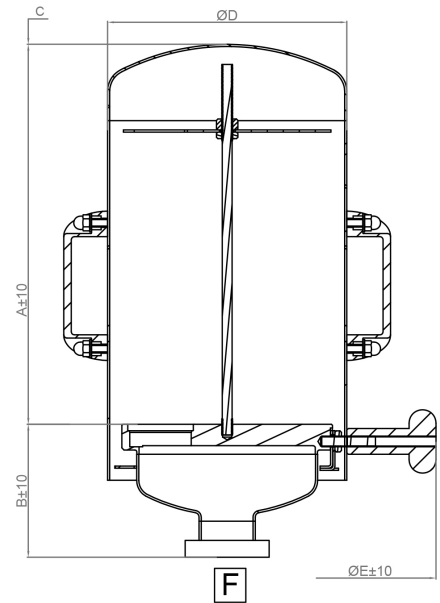
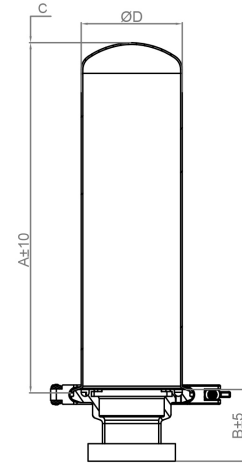

Ordering Information

PHV **XX** **X** **7** **XXXX**

Code	Cartridge Number	Code	Length (Nominal)	Code	Clamp ASME BPE ^F	Available for filter housing
01	1 cartridge	1	10" (250mm)	T020	2"	01
03	3 cartridges	2	20" (500mm)	T030	3"	03
05	5 cartridges	3	30" (750mm)	T040	4"	05, 08
08	8 cartridges	4	40" (1000mm)			
12	12 cartridges					

Code	DIN 11851 Liner Part ^F	Available for filter housing
L050	DN50	01
L080	DN80	03
L100	DN100	05, 08
L150	DN150	12

Code	DIN 11851 Male Part ^F	Available for filter housing
M050	DN50	01
M080	DN80	03
M100	DN100	05, 08
M150	DN150	12

Code	Weld ASME BPE ^F	Available for filter housing
W051	Ø50.8 x 1.65	01
W076	Ø76.2 x 1.65	03
W101	Ø101.2 x 2.11	05, 08

Code	Weld ISO 1127-1 ^F	Available for filter housing
W168	Ø168.3 x 2.00	12



Parker has a continuous policy of product development and although the company reserves the right to change specifications, it attempts to keep customers informed of any alterations. This publication is for general information only and customers are requested to contact our sales department for detailed information and advice on a products suitability for specific applications. All products are sold subject to the company's standard of sale.