

GS 1 series - DN 15 up to DN 150

Pneumatic sliding gate valve optionally with integrated positioner for regulating or shutting off liquid and gaseous media for industrial applications

- Space saving wafer type construction
- Lowest possible weight
- Quiet operation
- Fast response time
- Control of high differential pressures with small actuators
- Greatly reduced energy consumption rates due to short strokes and low actuating forces on the throttle element
- High Kvs-values
- Meets the requirements of TA-Luft 2021



Technical Information

Body design	flangeless, wafer-type construction dimensions acc. DIN EN 558-1 series 20 for flanges acc. DIN EN 1092-1, form B more versions see data-sheet 8021-GS3		
Nominal size	DN 15 to DN 150		
Nominal pressure	PN 40 acc. DIN 2401 (also for flanges PN 10 to PN 25)		
Fluid temperature	carbon steel body	-10°C to +350°C	
	stainless steel body	-60°C to +350°C	
Flange gaskets (customer side)	DIN EN 1514-1 or ANSI B16.21 in the respective nominal pressure rating		
Ambient temperature*	digital positioner -10°C up to +75°C analog positioner -15°C up to +60°C		
Flange gaskets (customer side)	DIN EN 1514-1 or ANSI B16.21 in the respective nominal pressure rating		
Rangeability / Characteristic analog positioner	30 : 1		
digital positioner	40 : 1 linear / 80 : 1 equal percentage		
Leakage **	Disc pair Carbon-stainless steel	Disc pair SFC	Disc pair STN 2
% of Kvs	< 0,0001	< 0,0005	< 0,001
IEC 60534-4	IV-S1	IV-S1	IV
EN 12266-1	E	F	F
Marking ATEX non electric	II 2G Ex h IIC T6...T1 X Gb II 2D Ex h IIIC 85°C...530°C X Db		
Specific leakage rate shaft and body sealing	ISO FE - BH - CC3 - SSA0 - t (-40°C / +350 °C) - PN40 - ISO 15848-1		

* Please consider the limitation of use of the positioner!

**With DN15 with reduction of less than 25%, different leakage rates possible.

Kvs-values see data sheet 8001.

Materials

Body	Carbon steel 1.0619	Stainless steel 1.4408	
Diaphragm housing	Aluminium, KTL- coated		
Actuator springs	Stainless steel 1.4310		
Packing	PTFE carbon filled (spring 1.4310)		
Actuating stem	Stainless steel 1.4571, roller burnished		
Bellows (optional)	Stainless steel 1.4571		
Fixed disc	Stainless steel 1.4571 coated	STN2 - disc	
Sliding disc	Special carbon material	SFC - disc (max. 300°C)	STN2 - disc
Coupling ring for disc	Stainless steel 1.4581		
Positioner Housing	Aluminium anodized, synthetic		

Positioner

For technical information of our positioners please refer to the corresponding data sheets.

Sliding Gate Valve 8021-GS1



with integrated digital positioner, Type 8049
(also on-off valves and valves with other side-mounted positioner)

Admissible Differential Pressure (For temperatures of up to 120°C)

For temperatures of 120°C and above:
obey application limits !

Disc pair: carbon - stainless steel
SFC - stainless steel

Diaphragm area	125 cm ²		250 cm ²		
	4,5	5,5	3	4	5,3
Supply air (bar)					
DN	Admissible differential pressures in bar				
15	40	40	40	40	40
20	40	40	40	40	40
25	40	40	40	40	40
32	40	40	40	40	40
40	40	40	40	40	40
50	40	40	40	40	40
65	37	40	40	40	40
80	23	29	40	40	40
100	15	16	24	33	33
125	10	11	16	23	23
150	7	7,5	13	16	16
Spring configuration	3	4	3	4	6

Standard

Disc pair: STN2

Diaphragm area	125 cm ²		250 cm ²		
	4,5	5,5	3	4	5,7
Spring range (bar)					
DN	Admissible differential pressures in bar				
15	40	40	40	40	40
20	40	40	40	40	40
25	40	40	40	40	40
32	40	40	40	40	40
40	26	27	27	27	27
50	18	20	31	40	40
65	15	16	26	38	38
80	9	9,5	15	22	22
100	5	5,5	9	13,5	13,5
125	3	3,5	6	8,9	8,9
150	2	2,5	4,5	7,8	7,8
Spring configuration	3	4	3	4	6

Standard

Sliding Gate Valve 8021-GS1



with integrated p/p and i/p - positioner, Type 8047

Admissible Differential Pressure (For temperatures of up to 120°C)

For temperatures of 120°C and above: obey application limits !

**Disc pair: carbon - stainless steel
SFC - stainless steel**

Diaphragm area	125 cm ²		250 cm ²	
	4	5	3	4
Supply air (bar)				
DN	Admissible differential pressures in bar			
15	40	40	40	40
20	40	40	40	40
25	40	40	40	40
32	40	40	40	40
40	29	36	40	40
50	17	21	29	35
65	14	17	24	29
80	8	10	14	17
100	5	6	9	10
125	3	4	6	7
150	2	3	4	5
Spring configuration	3	4	3	4

Standard

Disc pair: STN2

Diaphragm area	125 cm ²		250 cm ²	
	4	5	3	4
Supply air (bar)				
DN	Admissible differential pressures in bar			
15	40	40	40	40
20	37	40	40	40
25	25	31	40	40
32	17	22	30	36
40	11	14	19	24
50	6	8	11	13
65	5	6	9	11
80	3	3,5	5	6
100	1,5	2	3	4
125	-	1,5	2	2,5
150	-	1	1,5	1,8
Spring configuration	3	4	3	4

Standard

Applications limits for GS1-Valves PN 40

DN	Sliding unit: carbon/SFC - stainless steel, coated max. admissible pressures for GS1-valves						Sliding unit: carbon - STN2 max. admissible pressures for GS1-valves					
	100°C	150°C	200°C	250°C	300°C	350°C	100°C	150°C	200°C	250°C	300°C	350°C
15 - 25	40	36	31	28	26	24	40	36	31	28	26	24
32	40	36	31	28	26	24	40	36	31	28	25	22
40	40	36	31	28	26	24	26	25	24	19	16	14
50	40	36	31	28	26	24	40	36	31	28	26	24
65	40	36	31	28	26	24	37	35	31	27	22	19
80	40	36	31	28	26	24	22	20	19	16	13	11
100	24	23	22	19	17	16	13	12	12	9	8	6
125	16	15	14	13	11	10	8	8	7	6	5	4
150	16	16	16	16	14	13	10	10	9	7	6	5

Limitation for SFC-sliding discs: 300°C

Ordering Number System

8 0 2 1 / V G M Z S

1 2 3 4 5 6 7 8 9 10 11 12 13 14 15 16

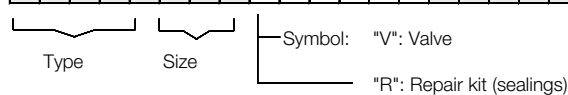

1 - 5 : Please quote all 5 sections.
6 - 12: Quote only if required.

1. Type	2. Connection	3. Body material	4. Safety position	5. Actuator
G	pneumatic sliding gate valve type 8021	0 flangeless design acc. DIN 2632-2635 (PN10-PN40)	0 spring closes 1 spring opens	3 diaphragm 125 cm ² 4 diaphragm 250 cm ² 5 diaphragm 500 cm ²

6. Special versions	7. Springs	8. Stem sealing	9. Moving disc	10. Fixed disc
M state, if further sections are quoted	- standard 1 2 springs 2 4 springs 3 6 springs 4 8 springs 5 10 springs D spring set 0,2-1 bar	- PTFE-packing, self adjusting (standard) 1 additional bellows 1.4571	- carbon S SFC-disc 9 STN2-disc	- stainless steel 1.4571, coated 1 STN2-disc

11. Kvs-values	12. Characteristic	13. Accessories	14. Positioner	15. Feedback	16. Special versions
- 100% (stand.) A red. to 63% 1 red. to 40% B red. to 25% 2 red. to 16% C red. to 10% 3 red. to 6,3% 4 red. to 2,5% 5 red. to 1% 8 red. to 2% 9 red. to 0,4%	- linear 1 equal percentage	Z accessories	- without 1 p/p positioner Type 8047 3 i/p positioner Type 8047 6 i/p positioner Type 8047 Eex ib IIC T6 with plug conn. M12x1 8 i/p positioner with plug conn. M12x1 C digital positioner, type 8049, 4 wire R digital positioner, type 8049, 2 wire W digital positioner, type 8049 ExPro, ATEX, IECEx K „digital positioner type 8049 ExPro-FM with base plate in stainless steel; Ta = -10°C to +75°C; IS Class I Division 1, Groups A, B, C, D; T4 Entity; Class I Zone 0 AEx ia IIC T4 Entity, IP65“ N digital positioner, type 8049 IO-Link version Y „digital positioner type 8049 ExPro-FM with base plate in stainless steel; Ta = -10°C to +75°C; NI Class I Division 2, Groups A, B, C, D; T4 NIFW, IP65“	- without 0 2 ind. limit switches M12x1 DC 10-30V 5 2 ind. limit switches M12x1 DC 10-55V D 1 ind. limit switch M12x1 DC 10-30V 6 1 ind. limit switch M12x1 DC 10-55V Y Feedback module RM4 for positioner type 8049 with 2 integrated limit switches acc. NAMUR (EN60947-5-6) P Feedback module RM5 for positioner type 8049 with 2 integrated limit switches	S further special versions

Ordering example: 8021/050VG0003M -- 91 -- Z3
GS-control valve type 8021 with pneumatic actuator, DN 50, PN 10/40, body material carbon steel, spring closes, actuator 125 cm², PTFE-V-shaped seal, STN2-disc and plate, Kvs-value 100 %, Flow characteristic linear, integrated i/p positioner

Sliding Gate Valve 8021-GS1

with integrated digital positioner, Type 8049

Dimensions and Weights

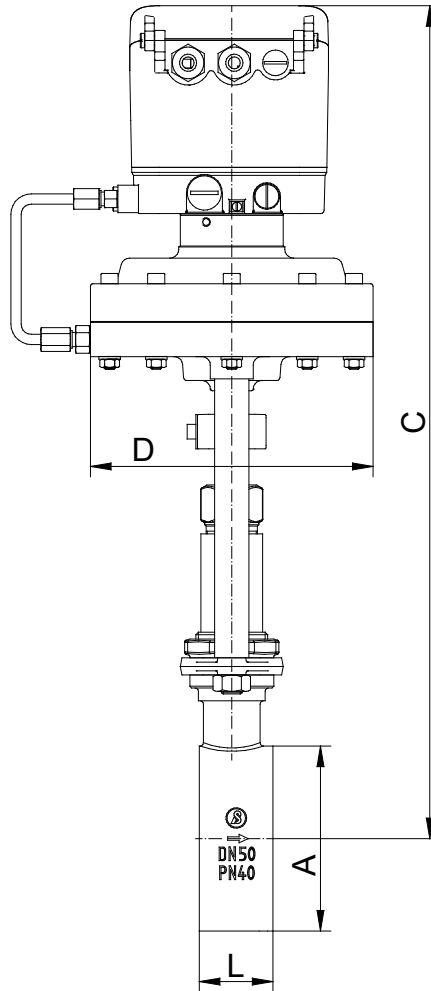

digital positioner ,Type 8049

DN	ØA	C	D Actuator		L	Stroke	Weight kg	
			125	250			D 125	D 250
15	53	460	165	222	33	6	6,9	9,1
20	62	465	165	222	33	6	7	9,2
25	72	470	165	222	33	6	7,2	9,4
32	82	475	165	222	33	6	7,5	9,7
40	92	480	165	222	33	6	7,7	9,9
50	108	490	165	222	43	8	8,9	11,1
65	127	500	165	222	46	8	9,7	11,9
80	142	510	165	222	46	8	10,3	12,5
100	164	520	165	222	52	8,5	11,8	14
125	194	535	165	222	56	8,5	15,5	17,7
150	219	550	165	222	56	8,5	17,4	19,6

Dimensions in mm

Sliding Gate Valve 8021-GS1

with integrated i/p and p/p - positioner, Type 8047

Dimensions and Weights

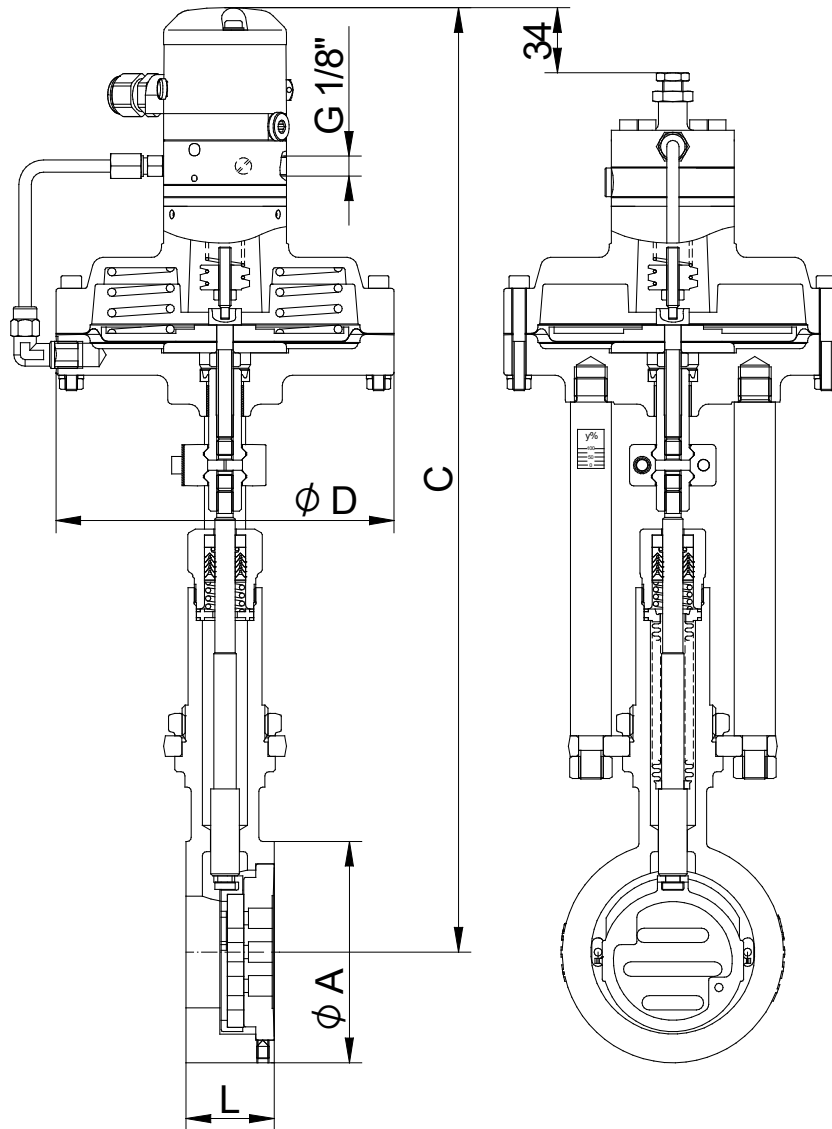

i/p - positioner, Type 8047

p/p - positioner, Type 8047

DN	Ø A	C*	Ø D Actuator		L	Stroke	Weight Actuator	
			D 125	D 250			D 125	D 250
15	53	430	165	222	33	6	6,9	9,1
20	62	435	165	222	33	6	7,0	9,2
25	72	440	165	222	33	6	7,2	9,4
32	82	445	165	222	33	6	7,5	9,7
40	92	450	165	222	33	6	7,7	9,9
50	108	460	165	222	43	8	8,9	11,1
65	127	470	165	222	46	8	9,7	11,9
80	142	480	165	222	46	8	10,3	12,5
100	164	490	165	222	52	8,5	11,8	14,0
125	194	505	165	222	56	8,5	14,0	16,2
150	219	520	165	222	56	8,5	15,5	17,7