

## GS 3 series - DN 15 up to DN 250

**Pneumatic sliding gate valve for controlling and shutting off liquid and gaseous media for industrial applications**

- Space saving wafer type construction
- Lowest possible weight
- Quiet operation
- Fast response time
- Control of high differential pressures with small actuators
- Greatly reduced energy consumption rates due to short strokes and low actuating forces on the throttle element
- High Kvs-values
- Meets the requirements of TA-Luft 2021



### Technical Information

Body design	flangeless, wafer-type construction for flanges acc. DIN EN 1092-1 Form B or ASME B16.5 RF more versions see on data-sheet 8020-GS1		
Nominal sizes	DN 15 to DN 250		
Nominal pressure acc. EN 1333	PN 40 (fits also to PN 10-25) PN 100 PN 16 and PN 25	DN 15 - DN 150 DN 15 - DN 80 DN 200 - DN 250	
Nominal pressure acc. ANSI	ANSI 150 ANSI 300 ANSI 600	DN 15 - DN 250 DN 15 - DN 150 DN 15 - DN 80	
Nominal pressure acc. JIS flanges with raised face	10K 20K	DN 15 - DN 50 DN 15 - DN 40	
Supply air pressure	max. 6 bar		
Media temperature	Versions from -60°C up to 350°C		
Ambient temperature*	-30°C up to +100°C		
Flange gaskets (customer side)	DIN EN 1514-1 or ANSI B16.21 in the respective nominal pressure rating		
Rangeability / characteristic	40 : 1 linear / 80 : 1 equal percentage		
Leakage **	Disc pair Carbon-stainless steel	Disc pair SFC	Disc pair STN 2
% of Kvs IEC 60534-4 EN 12266-1	< 0,0001 IV-S1 E	< 0,0005 IV-S1 F	< 0,001 IV F
Marking ATEX non electric	II 2G Ex h IIC T6...T1 X Gb II 2D Ex h IIIC 85°C...530°C X Db		
Spezific leakage rate shaft and body sealing	ISO FE - BH - CC3 - SSA0 - t (-40°C / +350 °C) - PN40 - ISO 15848-1		



\* Please consider the limitation of use of the positioner!

\*\* With DN15 with reduction of less than 25%, different leakage rates possible.  
Kvs-values see data sheet 8001.

### Fluid temperature

Rating	PN40	PN 16 / PN 25	PN 100	ANSI 150	ANSI 300	ANSI 600
Body material cpl. stainless steel						
Tmin [°C]	-60	-60	-60	-29	-29	-29
Tmax [°C]	350	350	350	350	350	350
Body material carbon steel with stainless steel body cover						
Tmin [°C]	-60	-60	-10	-20	-20	-20
Tmax [°C]	350	350	350	350	350	350

# Sliding Gate Valve 8020-GS3

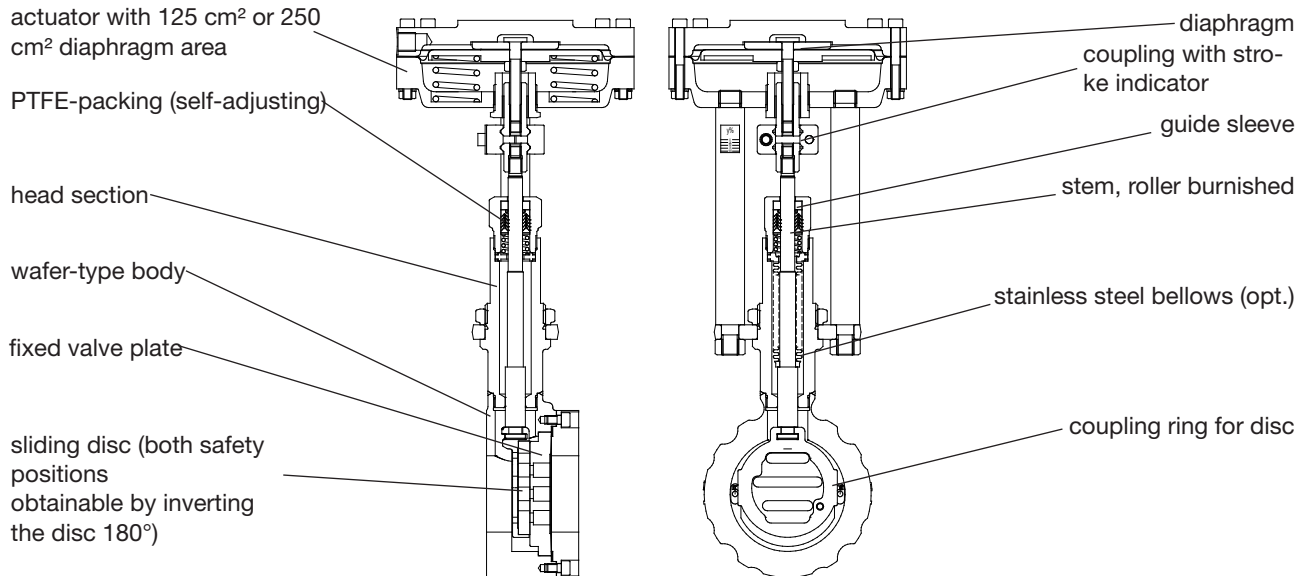

## Admissible differential pressures

(For temperatures of up to 120°C with PN-rating up to 38°C with ANSI-rating)

**For temperatures of 120°C (PN) or 38°C (ANSI) and above: obey application limits!**

**Disc pair: carbon - stainless steel coated  
SFC - stainless steel coated**

Actuator size	125 cm <sup>2</sup>					250 cm <sup>2</sup>				
	Spring range (bar)	0.2 to 1	1.0 to 2	1.5 to 3	1.8 to 3.8	2.1 to 4.5	0.2 to 1	0.8 to 1.4	1.2 to 2.2	1.5 to 2.7
Supply air (bar)	1,2	2,8	4,2	5,2	6,0	1,2	2,1	3,2	4	4,6
DN	Admissible differential pressures in bar									
15	4,4	102,1	102,1	102,1	102,1	18,9	102,1	102,1	102,1	102,1
20	3,8	102,1	102,1	102,1	102,1	16,4	102,1	102,1	102,1	102,1
25	3,2	88 (100)*	88 (102,1)*	88 (102,1)*	88 (102,1)*	13,7	88 (102,1)*	88 (102,1)*	88 (102,1)*	88 (102,1)*
32	2,6	100	102,1	102,1	102,1	11,3	102,1	102,1	102,1	102,1
40	2,0	66	88 (102,1)*	88 (102,1)*	88 (102,1)*	8,5	88 (102,1)*	88 (102,1)*	88 (102,1)*	88 (102,1)*
50	-	36	57	70	84	5,8	63	97	102,1	102,1
65	-	29	45	56	67	4,9	51	78	80	80
80	-	17	26	33	39	3,1	30	45	48	48
100	-	10	16	20	24	-	18	27	33	33
125	-	6,5	10	13	15	-	12	18	22	23
150	-	5	7,5	9	11	-	8,5	13	16	16
200	-	2,5	4,5	5,5	6,5	-	5	7,5	9	10
250	-	1,8	2,8	3,4	4,1	-	2,2	4,7	5,7	6,7
Springconfiguration	Code D	Code 2	Code 3	Code 4	Code 5	Code D	Code 2	Code 3	Code 4	Code 5

### Standard

\*: figures in brackets for bodys of carbon steel

	Upper limits for admissible pressures in bar					
	PN16	PN40	PN100	ANSI150	ANSI 300	ANSI 600
P max. carbon steel	16	40	100	19,6	51,1	102,1
P max. stainless steel				19,0	49,6	99,3

## Disc pair: STN 2

Actuator size	125 cm <sup>2</sup>					250 cm <sup>2</sup>				
	Spring range (bar)	0,2 to 1,0	1,0 to 2,0	1,5 to 3,0	1,8 to 3,8	2,1 to 4,5	0,2 to 1,0	0,8 to 1,4	1,2 to 2,2	1,5 to 2,7
Supply air (bar)	1,2	3	4,4	5,4	6,0	1,2	2,2	3,3	4,0	4,8
DN	Admissible differential pressures in bar									
15	3,1	102,1	102,1	102,1	102,1	13,4	102,1	102,1	102,1	102,1
20	2,4	57	102,1	102,1	102,1	10,3	102,1	102,1	102,1	102,1
25	1,8	57	88	88 (102,1)*	88 (102,1)*	7,7	88 (102,1)*	88 (102,1)*	88 (102,1)*	88 (102,1)*
32	1,3	38	59	73	87	5,7	66	102,1	102,1	102,1
40	0,9	23	37	45	54	3,9	41	63	72	72
50	-	13	20	25	30	2,4	23	35	42	49
65	-	10	16	20	24	2	18	28	34	40
80	-	6	9	11	14	1,2	10	16	19	23
100	-	3,5	5,5	7	8,5	-	6,5	10	12	14
125	-	2,5	3,5	4,5	5,5	-	4	6,5	8	9
150	-	1,5	2,5	3,5	4	-	3	4,5	5,5	6,5
200	-	1	1,6	2	1,8	-	1,8	2,7	3,3	3,9
250	-	-	1	1,2	1,4	-	1,1	1,7	2	2,4
Springconfiguration	Code D	Code 2	Code 3	Code 4	Code 5	Code D	Code 2	Code 3	Code 4	Code 5

### Standard

\*: figures in brackets for bodys of carbon steel

	Upper limits for admissible pressures in bar					
	PN16	PN40	PN100	ANSI150	ANSI 300	ANSI 600
P max. carbon steel	16	40	100	19,6	51,1	102,1
P max. stainless steel				19,0	49,6	99,3

The supply air pressure stated in the table is the minimum supply air pressure that has to be available. This is valid for the usage without positioner. For the usage with positioner the required supply air pressure is being determined by the adjustment of the positioner. For the standard version it is 4 bar ü. The spring configuration "D" allows the usage of a control valve without positioner but with limited performance. The valve can be controlled directly by a process controller with the norm signal of 0,2 up to 1 bar.

## Materials

Body*	Stainless steel 1.4408	Carbon steel 1.0619
Bodycover*	Stainless steel 1.4404 or 316 L	
Diaphragm housing	Aluminium, KTL coated	
Packing	PTFE (Carbon filled), spring 1.4310	
Actuating stem	Stainless steel 1.4571, roller burnished	
Bellows	Stainless steel 1.4571	
Fixed disc	Stainless steel 1.4571, coated	STN2-disc
Sliding disc	Special carbon material	SFC-disc (max. 300°C) STN2-disc
Guide ring for sliding disc	Stainless steel 1.4571	

\* Further Materials such as Hastelloy or Inconel on request

## Ordering Number System

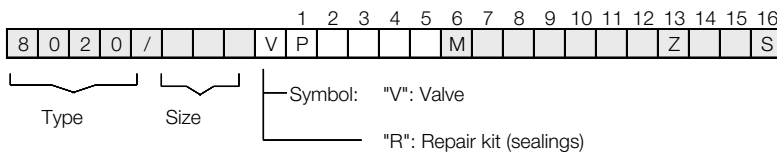

1 - 5 : Please quote all 5 sections.  
6 - 16: Quote only if required.

1.	Function	2.	Body design	3.	Body material	4.	Pilot function	5.	Actuator	6.	Special versions
P	sliding gate valve with pneumatic actuator (8020)	E F K G H	GS3 - flangeless design acc. ANSI 150 GS3 - flangeless design acc. ANSI 300 GS3 - flangeless design acc. ANSI 600 GS3 - flangeless design acc. DIN, PN10 - 40 GS3 - flangeless design acc. DIN, PN100	0 1	carbon steel 1.0619 stainless steel 1.4408	0 1	spring close spring open	3	diaphragm actuator 125 cm <sup>2</sup> diaphragm actuator 250 cm <sup>2</sup>	M A C E H	To state, if some pos. 7-16 are quoted groove and groove acc. DIN EN1092-1 groove and tongue acc. DIN EN1092-1 2x lowered face acc. DIN EN1092-1 lowered and raised face acc. DIN EN1092-1
7.	Springs	8.	Stem sealing	9.	Sliding disc	10.	Fixed disc	11.	Kvs-values	12.	Flow characteristic
- 1 2 3 4 5 D	standard 2 springs 4 springs 6 springs 8 springs 10 springs set of springs 0,2-1 bar (4 springs)	- 1	PTFE-V-shaped seal, self-adjusting (Standard) additional stainless steel bellow 1.4571 (max. pressure 33 bar)	- B 9 S	carbon material carbon material fibre forced STN2/STN3 Stainless Steel SFC-coated	- 1 3	stainless steel 1.4571 coated STN2-disc (only in combination with the pos. „9“) STN3-disc (only in combination with the pos. „9“)	- A 1 B 2 C 3 4 5 6 7 8 9	100 % (Stand.) red. to 63 % red. to 40 % red. to 25 % red. to 16 % red. to 10 % red. to 6,3 % red. to 2,5 % red. to 1 % red. To 20% red. to 12% red. to 2% red. to 0,4 %	- 1	linear equal percentage
13.	Accessories	14.	Positioner	15.	Signalling equipment	16.	Special version				
Z	To state, if in sections 14 and 15 accessories are quoted	- 1 2 3 4 6 7	without p/p - without gauges p/p - with gauges i/p- without gauges dto. with gauges i/p-intrinsically safe, without gauges dto. with gauges	- 0 1 2 5	without 2 limit switches inductive, M12x1 10-30V DC PNP 2 limit switches inductive, integr. in positioner i/p-converter 2 limit switches inductive, M 12x1 10-55V DC PNP/NPN	S	Other special versions have to be quoted in letters				

**Ordering example:** 8020/080VPG103M5 - - - - Z3  
sliding gate valve with pneumatic actuator, DN 80, PN 10/40, stainless steel, NC, actuator 125 cm<sup>2</sup> with 10 springs, PTFE-V-shaped seal, disc pair carbon material - stainless steel 1.4571 coated, linear characteristics, i/p-positioner ex-proof

## Application limitations for GS3 valves in stainless steel

These pressure must not be exceeded for GS-valves from the GS3-series made of stainless steel, even though the actuator power might allow it.

### PN40

DN	Sliding unit: carbon/SFC - stainless steel, coated						Sliding unit: STN2					
	max. admissible pressures for GS3-valves in stainless steel						max. admissible pressures for GS3-valves in stainless steel					
	100°C	150°C	200°C	250°C	300°C	350°C	100°C	150°C	200°C	250°C	300°C	350°C
15-32	40	40	40	40	40	40	40	40	40	40	40	40
40	40	40	40	40	40	40	40	40	40	40	40	37
50	40	40	40	40	40	40	40	40	40	40	40	40
65	40	40	40	40	40	40	40	40	40	40	37	32
80	40	40	40	40	40	40	36	34	33	26	22	19
100	33	33	33	33	33	33	32	31	30	24	20	17
125	23	23	23	23	23	23	21	21	19	16	13	11
150	16	16	16	16	16	16	15	15	14	11	9	8
200 (max. PN25)	16	16	15	13	12	11	8	7	6	5	4	3
250 (max. PN25)	10	9	9	8	7	6	5,7	5,4	5,1	4,1	3,4	2,9

Limitation for SFC-sliding discs: 300°C

### PN100

DN	Sliding unit: carbon/SFC - stainless steel, coated						Sliding unit: STN2					
	max. admissible pressures for GS3-valves in stainless steel						max. admissible pressures for GS3-valves in stainless steel					
	100°C	150°C	200°C	250°C	300°C	350°C	100°C	150°C	200°C	250°C	300°C	350°C
15	100	100	100	93	84	79	100	100	100	93	84	79
20	100	100	89	81	73	68	100	100	89	81	73	68
25	88	81	70	63	57	54	88	81	70	63	57	54
32	100	93	80	73	65	62	100	93	80	73	65	60
40	88	81	70	63	57	54	72	69	65	53	43	37
50	100	100	100	100	100	94	77	73	70	56	46	40
65	80	80	80	79	71	67	62	59	56	45	37	32
80	48	48	48	48	48	44	36	34	33	26	22	19

Limitation for SFC-sliding discs: 300°C

### ANSI150

DN	Sliding unit: carbon/SFC - stainless steel, coated								Sliding unit: STN2							
	max. admissible pressures for GS3-valves in stainless steel								max. admissible pressures for GS3-valves in stainless steel							
	38°C	50°C	100°C	150°C	200°C	250°C	300°C	350°C	38°C	50°C	100°C	150°C	200°C	250°C	300°C	350°C
15-125	19,0	18,4	16,2	14,8	13,7	12,1	10,2	8,4	19,0	18,4	16,2	14,8	13,7	12,1	10,2	8,4
150	16,0	16,0	16,0	14,8	13,7	12,1	10,2	8,4	16,2	16,2	16,2	14,8	13,7	11,8	9,7	8,4
200	16,0	16,0	16,0	14,8	13,7	12,1	10,2	8,4	10,5	10,0	8,3	7,6	6,9	5,5	4,5	3,9
250	10,4	10,4	10,4	9,9	9,4	8,4	7,4	6,8	5,7	5,7	5,7	5,4	5,1	4,1	3,4	2,6

Limitation for SFC-sliding discs: 300°C

### ANSI300

DN	Sliding unit: carbon/SFC - stainless steel, coated								Sliding unit: STN2							
	max. admissible pressures for GS3-valves in stainless steel								max. admissible pressures for GS3-valves in stainless steel							
	38°C	50°C	100°C	150°C	200°C	250°C	300°C	350°C	38°C	50°C	100°C	150°C	200°C	250°C	300°C	350°C
15-65	49,6	48,1	42,2	38,5	35,7	33,4	31,6	30,3	49,6	48,1	42,2	38,5	35,7	33,4	31,6	30,3
80	48,0	48,0	42,2	38,5	35,7	33,4	31,6	30,3	36,6	36,6	36,6	34,8	33,0	26,8	22,0	19,0
100	33,0	33,0	33,0	33,0	33,0	33,0	31,6	30,3	33,0	33,0	33,0	31,7	30,1	24,4	20,1	17,3
125	23,0	23,0	23,0	23,0	23,0	23,0	23,0	23,0	22,0	22,0	22,0	21,0	19,9	16,1	13,2	11,5
150	16,0	16,0	16,0	16,0	16,0	16,0	16,0	16,0	16,0	16,0	16,0	15,4	14,6	11,8	9,7	8,4
200	16,0	16,0	16,0	14,8	13,7	12,1	10,2	8,4	10,5	10,0	8,3	7,6	6,9	5,5	4,5	3,9

Limitation for SFC-sliding discs: 300°C

### ANSI600

DN	Sliding unit: carbon/SFC - stainless steel, coated								Sliding unit: STN2							
	max. admissible pressures for GS3-valves in stainless steel								max. admissible pressures for GS3-valves in stainless steel							
	38°C	50°C	100°C	150°C	200°C	250°C	300°C	350°C	38°C	50°C	100°C	150°C	200°C	250°C	300°C	350°C
15-20	99,3	96,2	84,4	77,0	71,3	66,8	63,2	60,7	99,3	96,2	84,4	77,0	71,3	66,8	63,2	60,7
25	88,0	88,0	84,4	77,0	70,1	63,7	57,3	54,2	88,0	88,0	84,4	77,0	70,1	63,7	57,3	54,2
32	99,3	96,2	84,4	77,0	71,3	66,8	63,2	60,7	99,3	96,2	84,4	77,0	71,3	66,8	63,2	60,2
40	88,0	88,0	84,4	77,0	70,1	63,7	57,3	54,2	72,5	72,5	72,5	69,0	65,5	53,1	43,6	37,7
50	99,3	96,2	84,4	77,0	71,3	66,8	63,2	60,7	77,7	77,7	77,7	73,9	70,2	56,9	46,7	40,4
65	80,0	80,0	80,0	77,0	71,3	66,8	63,2	60,7	62,5	62,5	41,7	59,5	56,4	45,8	37,6	32,5
80	48,0	48,0	48,0	48,0	48,0	48,0	48,0	44,5	36,6	36,6	36,6	34,8	33,0	26,8	22,0	19,0

Limitation for SFC-sliding discs: 300°C

## Application limitations for GS3 valves in carbon steel

These pressure must not be exceeded for GS-valves from the GS3-series made of carbon steel, even though the actuator power might allow it.

### PN40

DN	Sliding unit: carbon/SFC - stainless steel, coated max. admissible pressures for GS3-valves in carbon steel						Sliding unit: STN2 max. admissible pressures for GS3-valves in carbon steel					
	100°C	150°C	200°C	250°C	300°C	350°C	100°C	150°C	200°C	250°C	300°C	350°C
	15-50	40	40	40	40	40	40	40	40	40	40	40
65	40	40	40	40	40	40	40	40	40	37	32	
80	40	40	40	40	40	40	36	34	33	26	22	19
100	33	33	33	33	33	33	33	31	30	24	20	17
125	23	23	23	23	23	23	22	21	19	16	13	11
150	16	16	16	16	16	16	16	15	14	11	9	8
200 (max PN 25)	16	16	15	13	12	11	8	7	6	5	4	3
250 (max PN 25)	10	9	9	8	7	6	5,7	5,4	5,1	4,1	3,4	2,9

Limitation for SFC-sliding discs: 300°C

### PN100

DN	Sliding unit: carbon/SFC - stainless steel, coated max. admissible pressures for GS3-valves in carbon steel						Sliding unit: STN2 max. admissible pressures for GS3-valves in carbon steel					
	100°C	150°C	200°C	250°C	300°C	350°C	100°C	150°C	200°C	250°C	300°C	350°C
	15 - 20	100	100	100	100	100	100	100	100	100	100	100
25	100	100	100	100	100	94	87	100	100	100	94	87
32	100	100	100	100	100	100	99	100	100	84	69	60
40	100	100	100	100	100	94	87	72	69	65	53	43
50	100	100	100	100	100	100	94	77	73	70	56	46
65	80	80	80	80	80	80	76	62	59	56	45	37
80	48	48	48	48	48	44	44	36	34	33	26	22

Limitation for SFC-sliding discs: 300°C

### ANSI150

DN	Sliding unit: carbon/SFC - stainless steel, coated max. admissible pressures for GS3-valves in carbon steel								Sliding unit: STN2 max. admissible pressures for GS3-valves in carbon steel							
	38°C	50°C	100°C	150°C	200°C	250°C	300°C	350°C	38°C	50°C	100°C	150°C	200°C	250°C	300°C	350°C
	15-125	19,6	19,2	17,7	15,8	13,8	12,1	10,2	8,4	19,6	19,2	17,7	15,8	13,8	12,1	10,2
150	16,0	16,0	16,0	15,8	13,8	12,1	10,2	8,4	16,2	16,2	16,2	15,4	13,8	11,8	9,7	8,0
200	16,0	16,0	16,0	15,8	13,8	12,1	10,2	8,4	10,5	10,0	8,3	7,6	6,9	5,5	4,5	3,9
250	10,5	10,5	10,5	9,9	9,4	8,4	7,4	6,0	5,7	5,7	5,7	5,4	5,1	4,1	3,4	2,6

Limitation for SFC-sliding discs: 300°C

### ANSI300

DN	Sliding unit: carbon/SFC - stainless steel, coated max. admissible pressures for GS3-valves in carbon steel								Sliding unit: STN2 max. admissible pressures for GS3-valves in carbon steel							
	38°C	50°C	100°C	150°C	200°C	250°C	300°C	350°C	38°C	50°C	100°C	150°C	200°C	250°C	300°C	350°C
	15-50	51,1	50,1	46,6	45,1	43,8	41,9	39,8	37,6	51,1	50,1	46,6	45,1	43,8	41,9	39,8
65	51,1	50,1	46,6	45,1	43,8	41,9	39,8	37,6	41,7	41,7	41,7	39,7	37,6	33,5	37,6	33,0
80	48,0	48,0	46,6	45,1	43,8	41,9	39,8	37,6	36,6	36,6	36,6	34,8	33,0	26,8	22,0	19,0
100	33,0	33,0	33,0	33,0	33,0	33,0	33,0	33,0	33,0	33,0	33,0	31,7	30,1	24,4	20,0	17,5
125	23,0	23,0	23,0	23,0	23,0	23,0	23,0	23,0	22,1	22,1	22,1	21,0	19,9	16,1	13,2	11,5
150	16,0	16,0	16,0	16,0	16,0	16,0	16,0	16,0	16,0	16,0	16,0	15,4	14,6	11,8	9,7	8,4
200	16,0	16,0	16,0	14,8	13,7	12,1	10,2	8,4	10,5	10,0	8,3	7,6	6,9	5,5	4,5	3,9

Limitation for SFC-sliding discs: 300°C

### ANSI600

DN	Sliding unit: carbon/SFC - stainless steel, coated max. admissible pressures for GS3-valves in carbon steel								Sliding unit: STN2 max. admissible pressures for GS3-valves in carbon steel							
	38°C	50°C	100°C	150°C	200°C	250°C	300°C	350°C	38°C	50°C	100°C	150°C	200°C	250°C	300°C	350°C
	15-25	102,1	100,2	93,2	90,2	87,6	83,9	79,6	75,1	102,1	100,2	93,2	90,2	87,6	83,9	79,6
32	102,1	100,2	93,2	90,2	87,6	83,9	79,6	75,1	102,1	100,2	93,2	90,2	87,6	83,9	69,6	60,0
40	100,0	100,0	93,2	90,2	87,6	83,9	79,6	75,1	72,5	72,5	72,5	69,0	65,5	53,1	43,6	37,0
50	100,0	100,0	93,2	90,2	87,6	83,9	79,6	75,1	77,7	77,7	77,7	73,9	70,2	56,9	46,7	40,0
65	80,0	80,0	80,0	80,0	80,0	80,0	79,6	75,1	62,5	62,5	62,5	59,5	56,4	45,8	37,6	32,0
80	48,0	48,0	48,0	48,0	48,0	48,0	48,0	44,0	36,6	36,6	36,6	36,8	33,0	26,8	22,0	19,0

Limitation for SFC-sliding discs: 300°C

## Dimensions and Weights

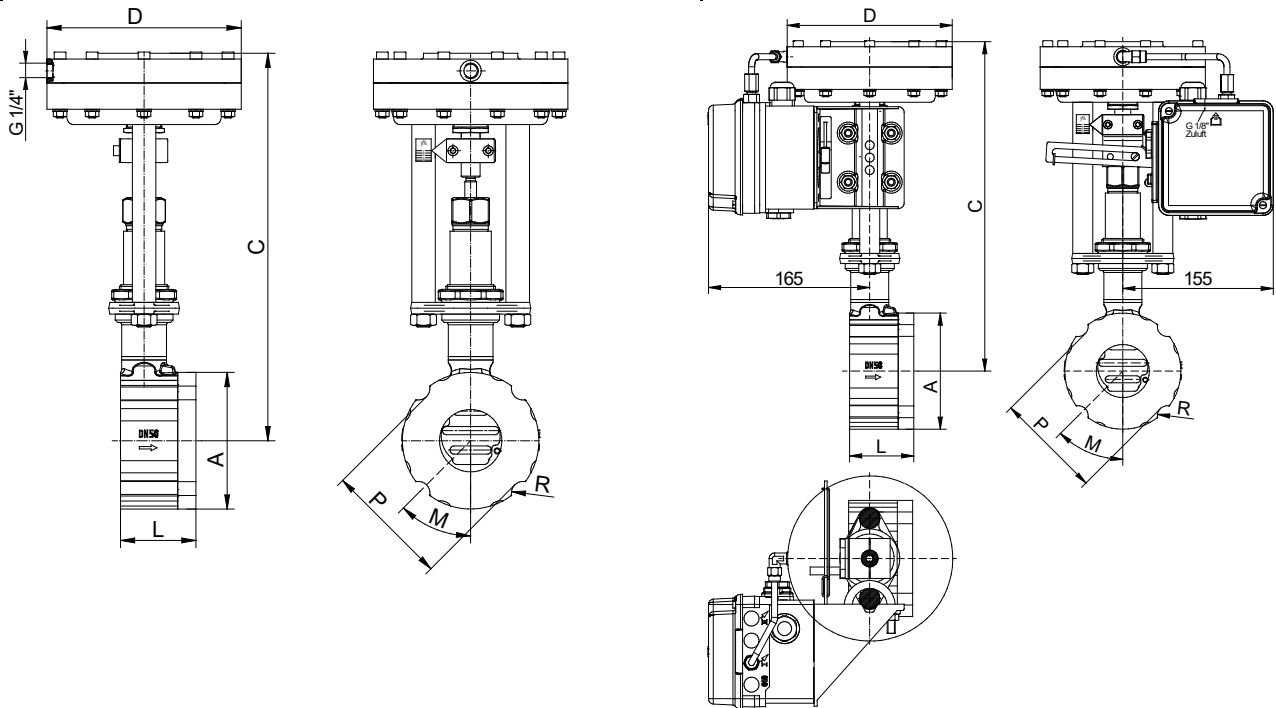

with electro-pneumatic positioner

DN	A (G/NPT)	B		C	ØD actuator size		L	SW	weight kg actuator size		Stroke
		G	NPT		125	250			125	250	
15	1/2"	15	13,6	305	165	222	127	30	8,8	11	6
20	3/4"	15	14,1	310	165	222	127	38	9,7	11,9	6
25	1"	18	16,8	315	165	222	140	46	12,4	14,6	6
32	1 1/4"	18	17,3	320	165	222	140	56	13,3	15,5	6
40	1 1/2"	18	17,3	325	165	222	152	64	14,7	16,7	6
50	2"	18	17,7	335	165	222	152	74	17,3	19,8	8

Dimensions in mm