

Motorvalve 8038

GS 3 series, DN 15 up to DN 250



Fast and high resolution motorvalve for control and switching of neutral through to highly aggressive media in process engineering, chemical industries and for plant equipment.

- Space saving wafer type construction
- Lowest possible weight (especially in larger sizes)
- Low operation noise level (quiet operation)
- Control of high differential pressures with small actuators
- Fast stroking speed
- Small dead band
- Smooth start and slow down
- Metall body



Technical Information of the Valve

Design	flangeless design further versions see data sheet 8038-GS1		
Nominal size	DN 15 up to DN 250		
Nominal pressure acc. DIN 2401 for flanges with facing type B	PN 40 (fits also to PN 10-25)	DN 15 - DN 150	
	PN 100	DN 15 - DN 80	
	PN 16	DN 200 - DN 250	
Nominal pressure acc. ANSI for flanges acc. ASME B16.5 RF	ANSI 150	DN 15 - DN 250	
	ANSI 300	DN 15 - DN 150	
	ANSI 600	DN 15 - DN 80	
Nominal pressure acc. JIS for "raiced face" flanges	10K	DN 15 - DN 50	
	20K	DN 15 - DN 40	
Media temperature	body 1.0570: -10°C up to +300°C body 1.4571: -60°C up to +350°C (+300°C für SFC)		
Rangeability	40 : 1		
Leakage (% of Kvs)	disc pair	disc pair	disc pair
	carbon-stainless steel < 0,0001	SFC < 0,0005	STN 2 < 0,001

K_{vs} -value see datasheet 8001.

NEW!

Technical Information of the Actuator

Driving force	2,0 kN
Power connections	24 V AC/DC 100 - 240 V 50/60Hz
Ambient temperature	-20°C up to +60°C
Storage temperature	-30°C up to +80°C
Mounting position	choice horizontal or vertical actuator only
Protection class (EN 60529)	IP 67
max. Power consumption	40 Watt
Dead band	±0,2% at min. 6mm stroke
Repeat accuracy	±0,1% at min. 6mm stroke
Set point range	adjustable 0(4) - 20 mA, 0(2) - 10 V
Feed back	adjustable 0(4) - 20 mA, 0(2) - 10 V
Self Monitoring	monitoring of the driving power, set point, actuator temperature, temperature of the electronic etc.
Diagnostic function	storage of motor and total service life, temperature- and way classes
Valve adaptation	automatic stroke adjustment to suit valve limits
Additional inputs	1 binary input (programmable)
Additional outputs	2 alarm outputs

Materials of the Valve

Body	carbon steel 1.0570 /1.0619	stainless steel 1.4571 /1.4581	
Head section	carbon steel 1.0570 /1.0619	stainless steel 1.4571 /1.4581	
Packing	PTFE (carbon filled), spring 1.4310		
Actuating stem	stainless steel, roller burnished		
Bellow	stainless steel 1.4571		
Fixed disc	stainless steel 1.4571, plated	STN2-disc	
Sliding disc	standard: special carbon material	SFC-disc	STN2-disc
Coupling ring for disc	stainless steel 1.4581		

Stroking Times

DN	Stroke	Stroking time (sec.) for the complete stroke				
		0,75 s/mm	1 s/mm	1,5 s/mm	2 s/mm	4 s/mm
15 - 40	6,25	4,6875	6,25	9,375	12,5	25
50 - 80	8,25	6,1875	8,25	12,375	16,5	33
100 - 150	8,75	6,5625	8,75	13,125	17,5	35

= Standard

Options

2 additional stroke limit switches	free adjustable volt free contacts (open/close)
Fail safe protection (in preparation)	Mounted in own body at actuator Safety position freely selectable
Communication software	with communication link, for parametrization and diagnosis of the actuator
Bluetoothmodul BT-1	Wireless connection to DeviceConfig configuration software (upgrade option)

Admissible Differential Pressures (For temperatures up to 120°C)

DN	max. differential pressure (bar)	
	disc - pair carbon/SFC stainless steel coated	disc - pair STN2
15	100	100
20	100	100
25	100	76
32	100	56
40	84	38
50	55	23
65	46	19
80	29	11
100	18	7
125	12	4,5
150	9,5	3,5
200	5,5	
250	3,4	

For temperatures of 120°C and above: Obey application limits!

P max.	Upper limits for admissible pressures in bar					
	PN16	PN40	PN100	ANSI 150	ANSI 300	ANSI 600
P max.	16	40	100	16	40	80

Ordering Number System

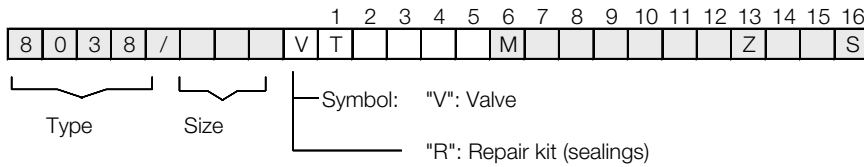

1 - 5 : Please quote all 5 sections.
6 - 16: Quote only if required.

1. Function	2. Body design	3. Body material	4. Security position	5. Actuator	6. Special versions	7. Motor voltages	8. Stem sealing
T GS-motor valve (type 8038)	E GS3-flangeless design acc. ANSI 150 F GS3-flangeless design acc. ANSI 300 K GS3-flangeless design acc. ANSI 600 G GS3-flangeless design acc. DIN PN10-PN40 H GS3-flangeless design acc. DIN PN100	0 carbon-steel 1.0570 / 1.0619 1 stainless steel 1.4571 / 1.4581	- without	A 2 kN, position-electronic, IP67	M to state, if some sections 7-19 are quoted	- 100 - 240V 50/60 Hz (Standard) 1 24V AC/DC	- PTFE-V-shaped seal, self-adjusting (Standard) 1 additional stainless steel bellow 1.4571 (max. 33 bar pressure)
9. Sliding disc	10. Fixed disc	11. Kvs-values	12. Seat characteristics	13. Accessories	14. Input signal	15. Limit switches	16. Special versions
- carbon material 9 STN2 S SFC	- stainless steel 1.4581, hard-chrome plated 1 STN2 (only in combination with the position "9" STN2-disc)	- 100 % (Stand.) A red. to 63 % 1 red. to 40 % 2 red. to 16 % 3 red. to 6.3 % 4 red. to 2.5 % 5 red. to 1 % 6 red. to 20 % 7 red. to 12 % 8 red. to 2 % 9 red. to 0,4 %	- linear 1 equal percentage	Z to state, if in sections 14 et seq. are quoted	- standard 4-20 mA or 2-10 V 3 0-20mA or 0-10V A binary control 24V DC - 3-point	- without 2 2 limit switches	S other special versions/ accessory
17. Stroking time	18. Special treatment	19. Feedback	20. Adjustments	21. Special additional version			
(1,5 s/mm) 1 0,75 s/mm 2 1 s/mm 3 2 s/mm 4 4 s/mm	- standard 1 for oxygen 2 silicon-free	- standard (at control actuators like control signal)	- standard death band ±0,2%	- without			

Ordering example:

8038/100VTG1 - AM - - - - - Z - 2

GS3-control valve with motor actuator, DN 100, PN 10/40, Stainless steel, actuator 2 kN, 100 - 240 V 50/60 Hz, PTFE-packing, discs: carbon - stainless steel 1.4571 coated, seat characteristics linear, 2 limit switches

Dimensions and Weights

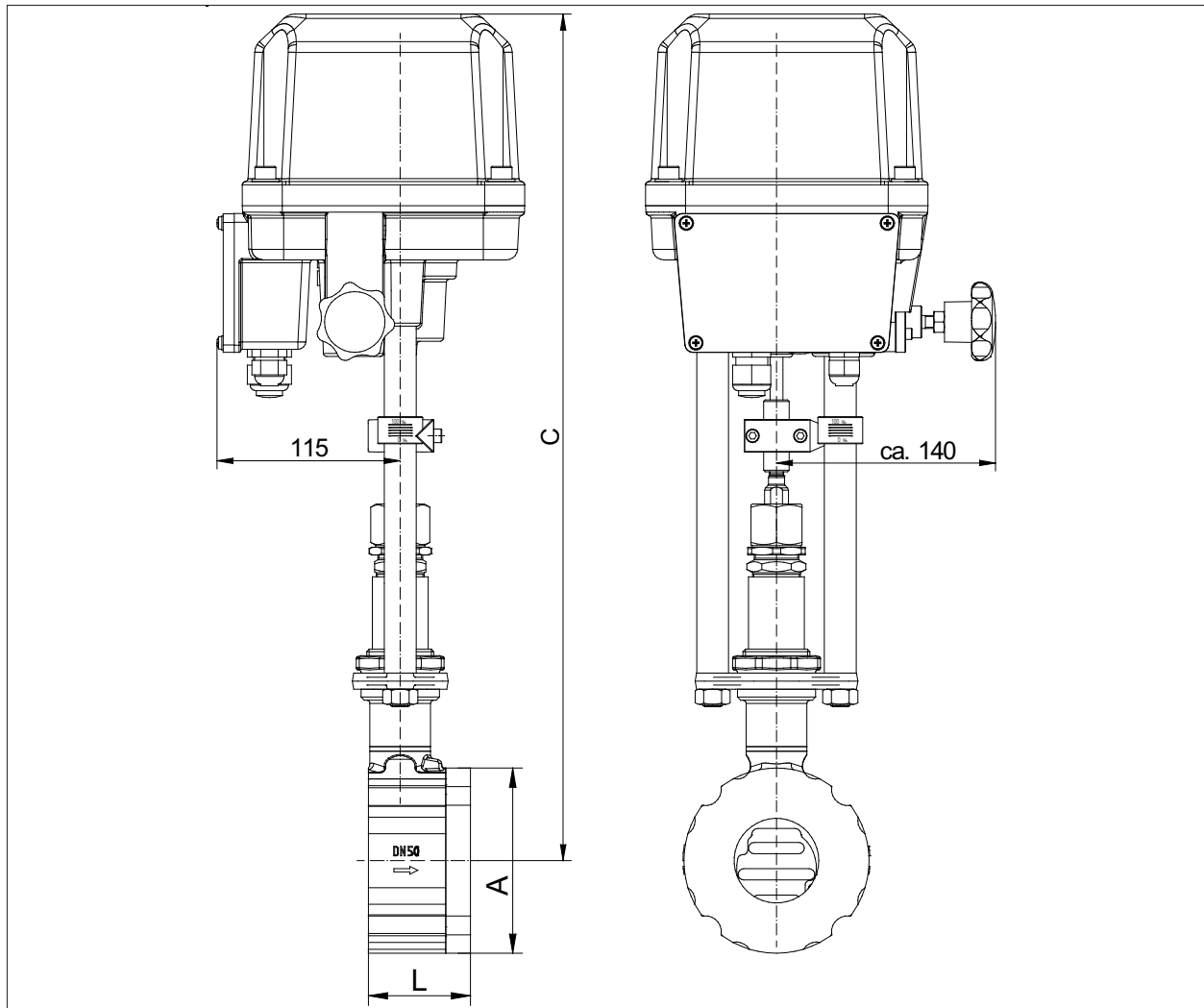

DN	ØA	C	L	Stroke	Weight kg
15	64	502	56	6	10,7
20	72	507	56	6	10,9
25	82	512	56	6	11,4
32	89	520	56	6	11,7
40	99	525	56	6	12,1
50	116	531	64	8	13,7
65	138	540	68	8	15,6
80	153	548	70	8	16,7
100	184	561	75	8,5	20,1
125	212	574	80	8,5	24,3
150	242	590	80	8,5	28,0
200	302	620	93	8,5	44,9
250	360	645	96	8,5	50,1

dimensions in mm

Application limits for GS3-valves made of stainless steel

These pressure must not be exceeded for GS-valves from the GS3-series made of stainless steel, even though the actuator power might allow it.

PN 40

DN	Sliding unit: carbon/SFC - stainless steel, coated max. admissible diff. pressures for GS3-valves					
	100°C	150°C	200°C	250°C	300°C	350°C
15 - 65	40	38	34	32	31	29
80	40	38	34	32	31	29
100	33	31	29	27	25	24
125	23	21	20	19	18	17
150	16	15	14	13	12	12
200 (PN16 only)	16	15	14	13	12	11,0
250 (PN16 only)	10,5	10	9,5	8,4	7,4	6,9

Sliding unit: carbon - STN2 max. admissible diff. pressures for GS3-valves					
100°C	150°C	200°C	250°C	300°C	350°C
40	38	34	32	31	29
36	34	33	26	22	19
33	31	26	24	20	17
22	21	17	16	13	11
16	15	13	11	9	8
-	-	-	-	-	-

Limitation for SFC-sliding discs: 300°C

PN 100

DN	Sliding unit: carbon/SFC - stainless steel, coated max. admissible pressures for GS3-valves					
	100°C	150°C	200°C	250°C	300°C	350°C
15	100	95	87	82	77	72
20	100	95	87	82	77	72
25	100	95	87	82	77	72
32	100	95	87	82	77	72
40	100	95	87	82	77	72
50	100	95	87	82	77	72
65	80	76	72	67	62	60
80	48	45	43	40	37	36

Sliding unit: STN2 max. admissible pressures for GS3-valves					
100°C	150°C	200°C	250°C	300°C	350°C
100	95	87	82	77	72
100	95	87	82	77	72
100	95	87	82	77	72
100	95	87	82	69	60
72	69	65	53	43	37
77	73	70	56	46	40
62	59	56	45	37	32
36	34	33	26	22	19

Limitation for SFC-sliding discs: 300°C

ANSI #150

DN	Sliding unit: carbon/SFC - stainless steel, coated max. admissible diff. pressures for GS3-valves					
	100°C	150°C	200°C	250°C	300°C	350°C
15 - 125	16	15	13	12	10	8
150	16	15	13	12	10	8
200	16	15	13	12	10	8
250	10,5	10	9,5	8,4	7,4	6,9

Sliding unit: carbon - STN2 max. admissible diff. pressures for GS3-valves					
100°C	150°C	200°C	250°C	300°C	350°C
16	15	13	12	10	8
16	15	13	11	9,5	8
-	-	-	-	-	-

Limitation for SFC-sliding discs: 300°C

ANSI #300

DN	Sliding unit: carbon/SFC - stainless steel, coated max. admissible pressures in bar for GS3-valves					
	100°C	150°C	200°C	250°C	300°C	350°C
15 - 65	40	38	35	33	31	30
80	40	38	35	33	31	30
100	33	31	29	27	25	24
125	23	21	20	19	18	17
150	16	15	14	13	12	12

Sliding unit: STN2 max. admissible pressures for GS3-valves					
100°C	150°C	200°C	250°C	300°C	350°C
40	38	35	32	31	29
36	34	33	26	22	19
33	31	26	24	20	17
22	21	17	16	13	11
16	15	13	11	9	8

Limitation for SFC-sliding discs: 300°C

ANSI #600

DN	Sliding unit: carbon/SFC - stainless steel, coated max. admissible pressures for GS3-valves					
	100°C	150°C	200°C	250°C	300°C	350°C
15 - 32	80	77	71	66	63	60
40	80	77	71	66	63	60
50	80	77	71	66	63	60
65	80	76	71	66	62	60
80	48	45	43	40	37	36

Sliding unit: STN2 max. admissible pressures for GS3-valves					
100°C	150°C	200°C	250°C	300°C	350°C
80	77	71	66	63	60
72	69	65	53	43	37
77	73	70	56	46	40
62	59	56	45	37	32
36	34	33	26	22	19

Limitation for SFC-sliding discs: 300°C