

# Motor Valve 8036

## GS 3 series, DN 15 up to DN 250



**Motor valve for control and switching of neutral through to highly aggressive media in process engineering, chemical industries and for plant equipment.**

- Space saving wafer type construction
- Lowest possible weight (especially in larger sizes)
- Low operation noise level (quiet operation)
- Control of high differential pressures with small actuators
- Fast response time

### Technical Information Valve

Design	flangeless design further versions see data sheet 8036-GS1		
Nominal size	DN 15 up to DN 250		
Nominal pressure acc. DIN 2401 for flanges with facing type B	PN 40 (fits also to PN 10-25)	DN 15 - DN 150	
	PN 100	DN 15 - DN 80	
	PN 16	DN 200 - DN 250	
Nominal pressure acc. ANSI for flanges acc. ASME B16.5 RF	ANSI 150	DN 15 - DN 250	
	ANSI 300	DN 15 - DN 150	
	ANSI 600	DN 15 - DN 80	
Nominal pressure acc. JIS for "raiced face" flanges	10K	DN 15 - DN 50	
	20K	DN 15 - DN 40	
Media temperature	body 1.0570: -10°C up to +300°C body 1.4571: -60°C up to +350°C (+300 for SFC)		
Rangeability	30 : 1		
Leakage (% of Kvs)	disc pair carbon-stainless steel < 0,0001	disc pair SFC < 0,0005	disc pair STN 2 < 0,001



Kvs-values see data sheet 8001.

### Materials

Body	stainless steel 1.4571 /1.4581	C-Stahl 1.0570 /1.0619
Head section	stainless steel 1.4571 /1.4581	
Packing	PTFE (carbon filled), spring 1.4310	
Actuating stem	stainless steel, roller burnished	
Bellow	stainless steel 1.4571	
Fixed disc	stainless steel 1.4571, plated	STN2-disc
Sliding disc	standard: special carbon material	SFC-disc STN2-disc
Coupling ring for disc	stainless steel 1.4581	

## Actuator with Electronic Positioner

### Technical Information

Driving force	2,3 kN
Type of duty (according IEC-34)	S2 30min S4 - 1200 c/h 50% ED
Power connections	24 V DC 24 V AC 110/120 V AC 230 V AC
Ambient temperature	-20°C up to +60°C
Mounting position	choice horizontal or vertical actuator only
Protection class (DIN 60529)	IP 65
max. Power consumption	30 Watt
Set point range	adjustable 0 - 20 mA, 0 - 10 V
Feed back	adjustable 0 - 20 mA, 0 - 10 V
Self Monitoring	torque, set point, temperature
Diagnostic function	storage of motor and total service life, number of motor starts, etc.
Valve adaptation	automatic stroke adjustment to suit valve limits

### Stroking Time (sec.)

DN	Stroking speed for the complete stroke		
	0,45 mm/s (50%)	0,67 mm/s (75%)	0,9 mm/s (100%)
15 - 40	13,9	9,3	6,9
50 - 80	18,4	12,3	9,2
100 - 250	19,5	13,1	9,7

= Standard

### Options

2 additional stroke limit switches	free adjustable volt free contacts (open/close)
Heater	anti condensation heater
Process controller	PI - process controller integrated in the actuator
Fair Safe Protection	via battery pack open or closed
Local control	mounted on the actuator
Communication software	by use of data care to configure actuator

### Admissible Differential Pressures (For temperatures of up to 120°C)

**For temperatures of 120°C and above:  
obey application limits !**

DN	max. differential pressure (bar)			
	carbon/SFC - stainless steel coated control	carbon/SFC - stainless steel coated on - off	STN2 control	STN2 on - off
15	100	100	100	100
20	100	100	100	100
25	100	100	88	100
32	100	100	65	100
40	97	100	45	72
50	63	100	27	53
65	53	80	22	44
80	34	48	13	26
100	21	33	8	16
125	14	23	5,5	11
150	11	16	4	8
200	6,5	12		
250	4	7,9		

Upper limits for admissible pressures in bar						
	PN16	PN40	PN100	ANSI 150	ANSI 300	ANSI 600
P max.	16	40	100	16	40	80

## Actuator without Electronic Positioner (function: open/close or 3-step-drive)

### Technical Information

Driving force	1 kN, 2 kN, 4,5 kN
Type of duty (according VDE 0530)	S2 30min S4 - 1200 c/h 50%ED
Power connections	24 V AC 110/120V AC 230 V AC
Ambient temperature	-20°C bis +80°C (S2) / -20°C bis +60°C (S4)
Mounting position	choice horizontal or vertical actuator only
Protection class (EN 60529)	IP 65
max. Power consumption	1 kN: 26W, 2 kN: 30W , 4,5kN: 47 W
Actuator protection	torque switch

### Options

2 additional stroke limit switches	free adjustable volt free contacts (open/close)
Heater	anti condensation heater
Feed back 4-20 mA	in 2-wire or 3-wire design
Local control	mounted key pad on actuator

### Stroking Time (sec.)

DN	Stroking speed for the complete stroke		
	1 kN	2 kN	4,5 kN
15 - 40	25	25	12,5
50 - 80	33	33	16,5
100 - 250	35	35	17,5

(other regulating speeds on request)

### Admissible Differential Pressures (For temperatures of up to 120°C)

**For temperatures of 120°C and above:  
obey application limits !**

DN	max. differential pressure (bar)					
	disc - pair carbon/SFC stainless steel coated			disc - pair STN2		
	1 kN	2 kN	4,5 kN	1 kN	2 kN	4,5 kN
15	88	100	100	62	100	100
20	76	100	100	48	100	100
25	64	100	100	36	76	100
32	52	100	100	26	56	100
40	39	84	100	18	38	72
50	26	55	100	11	23	53
65	22	46	80	9	19	44
80	14	29	48	5	11	26
100	8,5	18	33	3	7	16
125	6	12	23	2	4,5	11
150	4,5	9,5	16	1,5	3,5	8
200	2,5	5,5	12,5			
250	1,6	3,4	7,9			

P max.	Upper limits for admissible pressures in bar					
	PN16	PN40	PN100	ANSI 150	ANSI 300	ANSI 600
	16	40	100	16	40	80

## Ordering Number System

1 2 3 4 5 6 7 8 9 10 11 12 13 14 15 16

8	0	3	6	/			V	T					M				Z			S
---	---	---	---	---	--	--	---	---	--	--	--	--	---	--	--	--	---	--	--	---

1 - 5 : Please quote all 5 sections.  
6 - 16: Quote only if required.

Type                      Size

Symbol: "V": Valve  
"R": Repair kit (sealings)

1. Function	2. Body design	3. Body material	4. Security position	5. Actuator	6. Special versions	7. Motor voltages	8. Stem sealing
T GS-motor valve (type 8036)	E GS3 - flangeless design acc. ANSI 150 F GS3 - flangeless design acc. ANSI 300 K GS3 - flangeless design acc. ANSI 600 G GS3 - flangeless design acc. DIN, PN10-PN40 H GS3 - flangeless design acc. DIN, PN100	0 carbon-steel 1.0570 / 1.0619  1 stainless steel 1.4571 / 1.4581	- without  1 Safety position closed in the case of power failure  2 Safety position open at power failure	R 2,3 kN, position-electronic, IP65 1 2 kN, IP65 (On - Off) 2 4,5 kN, IP65 (On - Off) 4 1 kN, IP65 (On - Off)	M to state, if some sections 7-16 are quoted A groove and groove acc. DIN EN1092-1 C groove and tongue acc. DIN EN1092-1 E 2x lowered face acc. DIN EN1092-1 H lowered and raised face acc. DIN EN1092-1	- 230V 50/60 Hz (Standard) 1 24V 50/60 Hz 3 24V DC (only with 2,3 kN) 4 115V 50/60 Hz	- PTFE-V-shaped seal, self-adjusting (Standard) 1 additional stainless steel bellow 1.4571 (max. 33 bar pressure)

9. Sliding disc	10. Fixed disc	11. Kvs-values	12. Seat characteristics	13. Accessories	14. Input signal	15. Limit switches	16. Special versions
- Carbon material  9 STN2 S SFC	- stainless steel 1.4581, hard-chrome plated 1 STN2 (only in combination with the position "9" STN2-disc)	- 100 % (Stand.) A red. to 63 % 1 red. to 40 % 2 red. to 16 % 3 red. to 6,3 % 4 red. to 2,5 % 5 red. to 1 % 6 red. to 20 % 7 red. to 12 % 8 red. to 2 % 9 red. to 0,4 %	- linear  1 equal percentage	Z to state, if in sections 14 and 15 accessories are quoted	- Standard with electronic positioner 4-20 mA 3 0-10 V 4 2-10 V	- without 2 2 limit switches	S Other special versions have to be quoted in letters

17. Stroking time	18. Special treatment	19. Positioner
- Standard  1 0,9 mm/sec (2,3 kN) 2 0,45 mm/sec (2,3 kN)	-	- Standard (for controlling as input signal) 2 feed back 4-20 mA, 2 wire for open/close

Ordering example: 8036/100VTG11RM- - - - - Z-2  
GS3-control valve with motor actuator, DN 100, PN 10/40, stainless steel, safety position closed, actuator 2,3kN, 230 V 50/60 Hz, PTFE-packing, discs: carbon - stainless steel 1.4571 coated, seat characteristics linear, 2 limit switches

## Application limitations for GS3 valves in stainless steel

These pressure must not be exceeded for GS-valves from the GS3-series made of stainless steel, even though the actuator power might allow it.

### PN 40

DN	Sliding unit: carbon/SFC - stainless steel, coated max. admissible diff. pressures for GS3-valves					
	100°C	150°C	200°C	250°C	300°C	350°C
15 - 65	40	38	34	32	31	29
80	40	38	34	32	31	29
100	33	31	29	27	25	24
125	23	21	20	19	18	17
150	16	15	14	13	12	12
200 (PN16 only)	16	15	14	13	12	11,0
250 (PN16 only)	10,5	10	9,5	8,4	7,4	6,9

DN	Sliding unit: carbon - STN2 max. admissible diff. pressures for GS3-valves					
	100°C	150°C	200°C	250°C	300°C	350°C
15 - 65	40	38	34	32	31	29
80	36	34	33	26	22	19
100	33	31	26	24	20	17
125	22	21	17	16	13	11
150	16	15	13	11	9	8
200	-	-	-	-	-	-
250	-	-	-	-	-	-

Limitation for SFC-sliding discs: 300°C

### PN 100

DN	Sliding unit: carbon/SFC - stainless steel, coated max. admissible pressures for GS3-valves					
	100°C	150°C	200°C	250°C	300°C	350°C
15	100	95	87	82	77	72
20	100	95	87	82	77	72
25	100	95	87	82	77	72
32	100	95	87	82	77	72
40	100	95	87	82	77	72
50	100	95	87	82	77	72
65	80	76	72	67	62	60
80	48	45	43	40	37	36

DN	Sliding unit: STN2 max. admissible pressures for GS3-valves					
	100°C	150°C	200°C	250°C	300°C	350°C
15	100	95	87	82	77	72
20	100	95	87	82	77	72
25	100	95	87	82	77	72
32	100	95	87	82	69	60
40	72	69	65	53	43	37
50	77	73	70	56	46	40
65	62	59	56	45	37	32
80	36	34	33	26	22	19

Limitation for SFC-sliding discs: 300°C

### ANSI #150

DN	Sliding unit: carbon/SFC - stainless steel, coated max. admissible diff. pressures for GS3-valves					
	100°C	150°C	200°C	250°C	300°C	350°C
15 - 125	16	15	13	12	10	8
150	16	15	13	12	10	8
200	16	15	13	12	10	8
250	10,5	10	9,5	8,4	7,4	6,9

DN	Sliding unit: carbon - STN2 max. admissible diff. pressures for GS3-valves					
	100°C	150°C	200°C	250°C	300°C	350°C
15 - 125	16	15	13	12	10	8
150	16	15	13	11	9,5	8
200	-	-	-	-	-	-
250	-	-	-	-	-	-

Limitation for SFC-sliding discs: 300°C

### ANSI #300

DN	Sliding unit: carbon/SFC - stainless steel, coated max. admissible pressures in bar for GS3-valves					
	100°C	150°C	200°C	250°C	300°C	350°C
15 - 65	40	38	35	33	31	30
80	40	38	35	33	31	30
100	33	31	29	27	25	24
125	23	21	20	19	18	17
150	16	15	14	13	12	12

DN	Sliding unit: STN2 max. admissible pressures for GS3-valves					
	100°C	150°C	200°C	250°C	300°C	350°C
15 - 65	40	38	35	32	31	29
80	36	34	33	26	22	19
100	33	31	26	24	20	17
125	22	21	17	16	13	11
150	16	15	13	11	9	8

Limitation for SFC-sliding discs: 300°C

### ANSI #600

DN	Sliding unit: carbon/SFC - stainless steel, coated max. admissible pressures for GS3-valves					
	100°C	150°C	200°C	250°C	300°C	350°C
15 - 32	80	77	71	66	63	60
40	80	77	71	66	63	60
50	80	77	71	66	63	60
65	80	76	71	66	62	60
80	48	45	43	40	37	36

DN	Sliding unit: STN2 max. admissible pressures for GS3-valves					
	100°C	150°C	200°C	250°C	300°C	350°C
15 - 32	80	77	71	66	63	60
40	72	69	65	53	43	37
50	77	73	70	56	46	40
65	62	59	56	45	37	32
80	36	34	33	26	22	19

Limitation for SFC-sliding discs: 300°C

## Dimensions and Weights

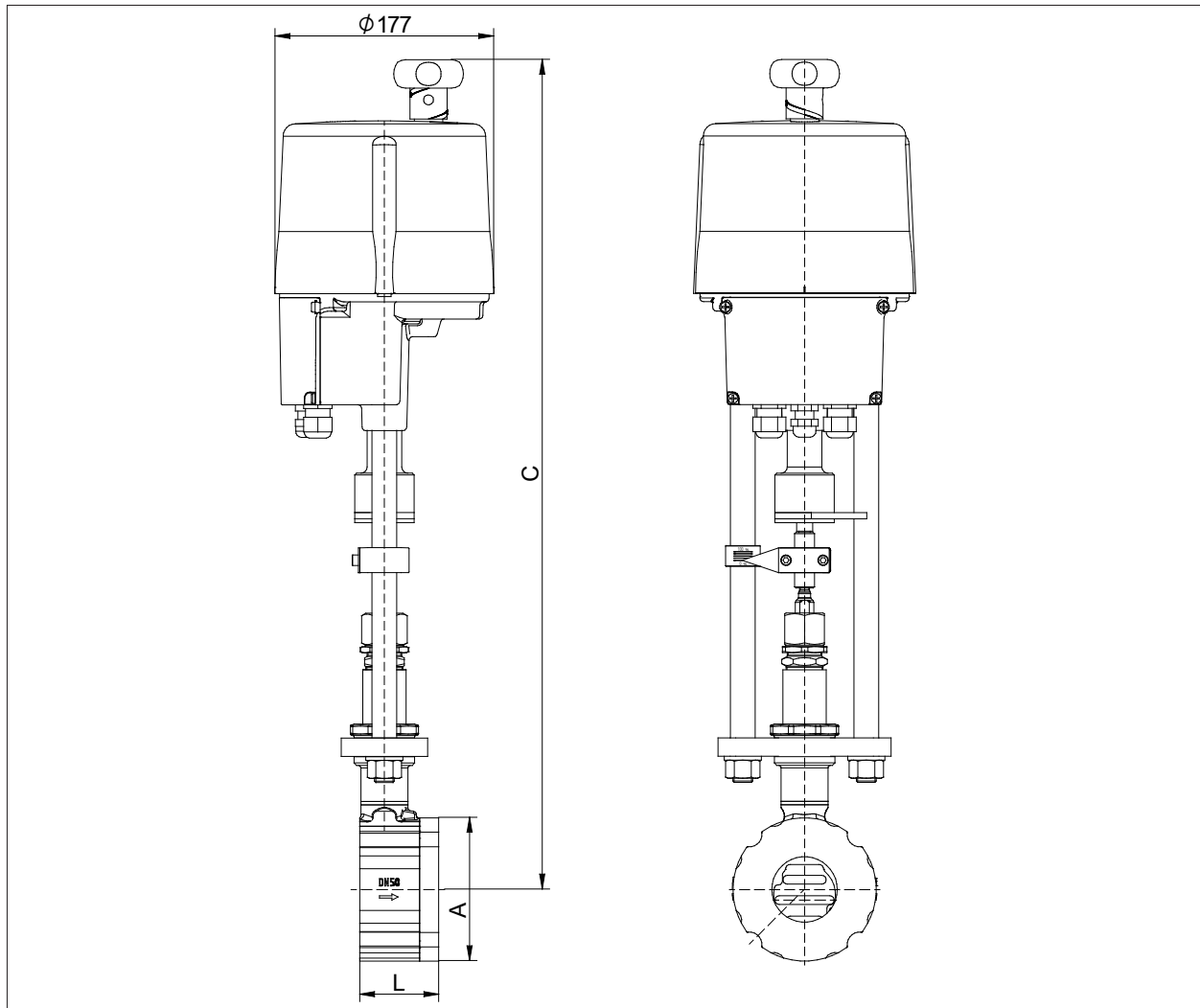

DN	$\phi A$ mm	C mm	L mm	Stroke mm	Weight kg
15	64	592	56	6	8,2
20	72	597	56	6	8,4
25	82	602	56	6	8,7
32	89	607	56	6	8,7
40	99	612	56	6	9,3
50	116	622	64	8	10,8
65	138	632	68	8	12,3
80	153	637	70	8	13,6
100	184	652	75	8,5	16,7
125	212	667	80	8,5	19,1
150	242	682	80	8,5	22,7
200	302	712	93	8,5	39,5
250	360	738	96	8,5	44,8

Dimensions in mm