

Ball Sector Valve 4040

DN 25 up to DN 300

Pneumatic control valve for the control of neutral and aggressive fluids with integrated positioner

- DN 25 up to DN300
- High Kvs-values up to 3840
- Excellent control characteristics
- Suitable for abrasive media
- Easily exchangeable seat ring
- Low maintenance
- Actuators can be easily fitted
- Efficient and easy to install
- Optional volume booster Type 4090 (from DN150) in order to reduce the response time
- Optional with face to face dimension acc. ANSI ISA 75.08.02



Technical Information Valve

Design	DN 25 - DN 250 flangeless wafer type DN 300 flange connection	
Nominal sizes	DN 25 up to DN 300	
Body material	cast parts	1.4408 (CF8M)
	turned parts	1.4404 (316L)
Material of the bearing shaft	1.4122	
Bearing material	high temperature plain bearing	
Connection to the actuator	mounting kit DIN/ISO 5211	
Nominal pressure	DN 25 - DN 50	PN40 (for flanges PN 10 - PN 40), ANSI300, ANSI150
	DN 65 - DN100	PN25 (for flanges PN 10 - PN 25), ANSI150
	DN 125 - DN 300	PN16 (for flanges PN 10 - PN 16), ANSI150
Fluid Temperature	-40°C up to +220°C	depending on the sealings
Ambient temperature	-40°C up to +80°C	depending on the sealings
	special version on request	
Vacuum	up to 50 mbar abs.	
Characteristic	almost equal percentage	
Rangeability	300:1	
Specific leakage rate shaft and body sealing	series KS2, DN25-DN250: ISO FE-BH-CC3-SSA0-t(-40°C/+220°C)-PN40-ISO 15848-1 series KS1; DN300: ISO FE-BH-CC-SSA0-t(RT)-PN16-ISO 15848-1	

Working pressure max.

DN	maximum differential pressure (delta p)									
	seat ring PTFE			seat ring PEEK				seat ring Stellite		
	up to 80°C bar	120°C bar	170°C bar	up to 80°C bar	120°C bar	170°C bar	220°C bar	up to 80°C bar	170°C bar	220°C bar
25-50	25	16	6	40	40	25	16	40	40	25
65-100	16	12	5	25	25	16	10	25	25	16
125-300	16	12	4	16	16	12	8	16	16	12

Actuators for mounting according DIN/ISO5211, pilot pressure 5 - 6 bar
(for less than 5 bar pilot pressure, please inform us)

Temperature limits

Seating	Sealing seating									
	Viton		EPDM		NBR		FFKM		PFA-Silicone	
	Tmin [°C]	Tmax [°C]	Tmin [°C]	Tmax [°C]	Tmin [°C]	Tmax [°C]	Tmin [°C]	Tmax [°C]	Tmin [°C]	Tmax [°C]
PTFE	-15	170	-40	140	-30	100	-15	170	-45	170
PEEK	-15	200	-40	140	-30	100	-15	220	-45	220
Stellite	-15	200	-40	140	-30	100	-15	220	-45	220

Kvs-Values

DN	Kvs-Value reduced to				
	100%	63%	40%	25%	6,3%
25	21	12,7	8,4	5,25	1,45
40	70	40,32	25		
50	109	60,3			
65	155				
80	300				
100	390				
125	756				
150	810				
200	1365				
250	2220				
300	3840				

Leakage

Seat ring	Ball sector	Leakage	
		Amount of the max. Kvs-value	class acc. EN 60534-4: (IEC 60534-4)
PTFE or PEEK	stainless steel polished	5x10 ⁻⁷	IV-S1
PTFE or PEEK	stainless steel lapped		VI
PTFE or PEEK	stainless steel hard chrome plated	5x10 ⁻⁷	IV-S1
PTFE or PEEK	stainless steel, hard chrome plated + lapped		VI
Stellite	stainless steel, hard chrome plated + lapped	5x10 ⁻⁶	IV-S1

Operating time with positioner 8049

DN	operating time opening 5% to 95%			operating time closing 5% to 95%		
	Standard 100 NI/min	with volume booster Type 4090	with external solenoid valves (1500NL)	Standard 100 NI/min	with volume booster Type 4090	with external solenoid valves (1500NL)
100	4,0 s	1,9 s	1,0 s	5,4 s	3,0 s	1,2 s
150	7,0 s	2,5 s	1,5 s	8,5 s	4,0 s	1,6 s
200	11,0 s	4,0 s	1,8 s	13,0 s	8,0 s	1,9 s
250	14,0 s	5,0 s	2,5 s	17,5 s	10,0 s	2,6 s
300	23,0 s	9,0 s	4,5 s	43,0 s	18,0 s	6,0 s

Torques and mounting kits

for retrofitting actuators

DN	rotation angle nominal	max. nominal pressure PN	max. nominal pressure ANSI	req. torque [Nm]		mounting kit ISO 5211 diagonal square shaft	
				on/off-operation	control operation	series 1	series 2
25	90°	PN40	ANSI 300	15	25	F04/SW11	F05/SW14
40	90°	PN40	ANSI 300	30	50	F05/SW14	F07/SW17
50	90°	PN40	ANSI 300	30	50	F05/SW14	F07/SW17
65	90°	PN25	ANSI 150	60	100	F07/SW17	F10/SW22
80	90°	PN25	ANSI 150	60	100	F07/SW17	F10/SW22
100	90°	PN25	ANSI 150	90	150	F07/SW17	F10/SW22
125	90°	PN16	ANSI 150	150	250	F10/SW22	F12/SW27
150	90°	PN16	ANSI 150	150	250	F10/SW22	F12/SW27
200	90°	PN16	ANSI 150	210	350	F12/SW27	F14/SW36
250	90°	PN16	ANSI 150	360	600	F12/SW27	F14/SW36
300	90°	PN16	ANSI 150	900	1500	F14/SW36	F16/SW46

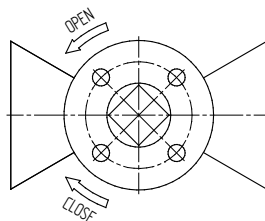

Ball Sector Valve with reduced Kvs-values

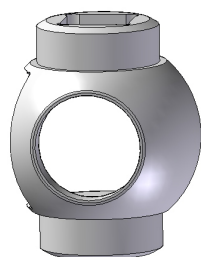

100%

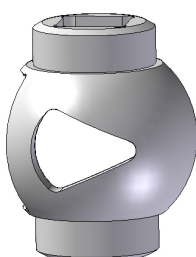

reduced to
63%

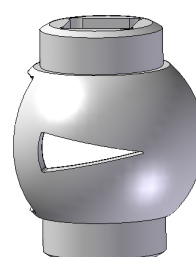

reduced to
25%

Ball Sector Valve Type 4040 with hand wheel gear box



Dimensions KS2 with actuator and positioner 8049

Sealing of the bearing shaft with PTFE-packing

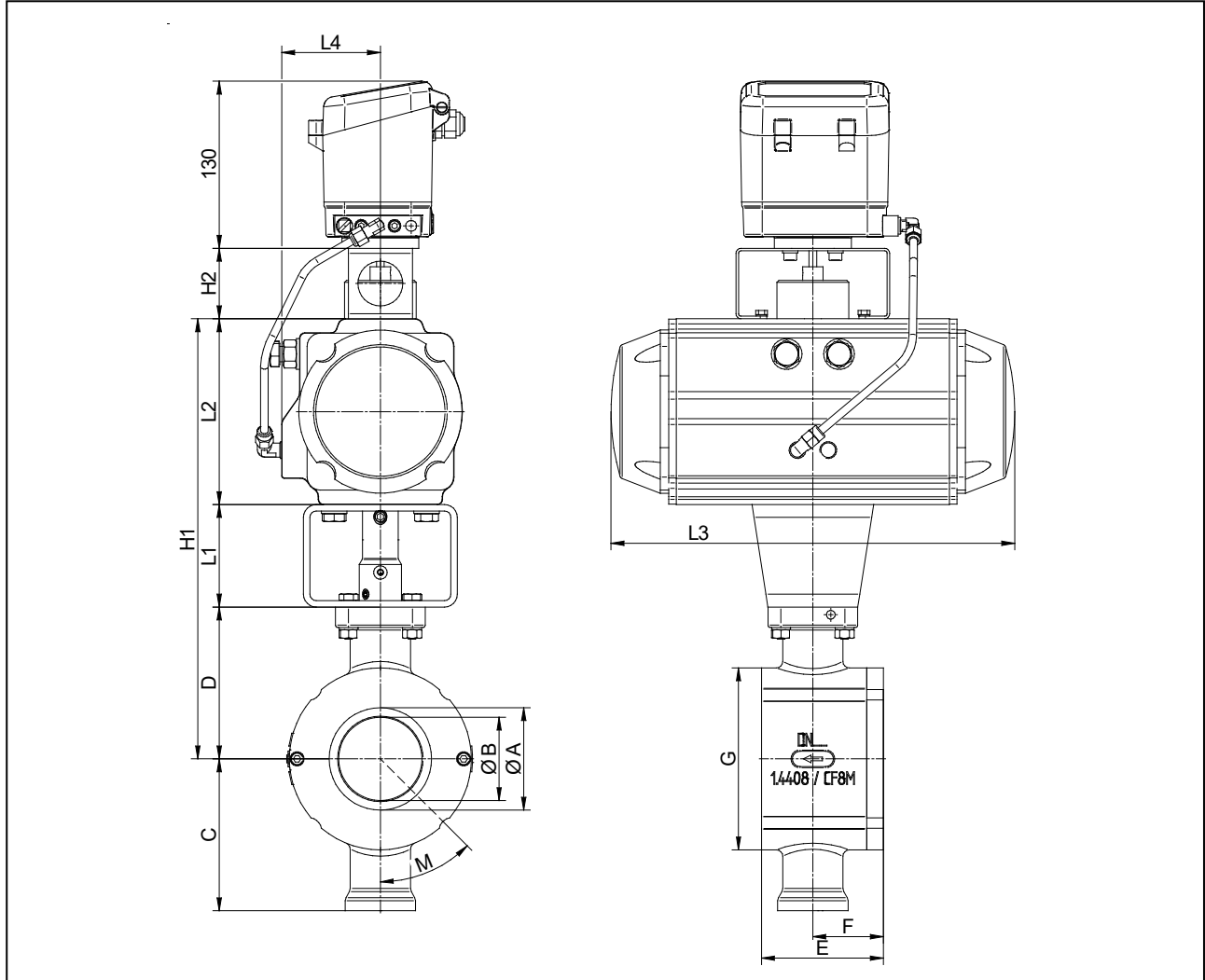

DN	actuator single acting						actuator double acting					
	L1	L2	L3	L4	H1	weight [kg]	L1	L2	L3	L4	H1	weight [kg]
25	60	102	210,5	52	247	6,2	60	85	158,5	47	230	4,3
40	60	115	247,5	56,8	267	8,3	60	102	210,5	52	254	6,7
50	60	115	247,5	56,8	270	9,1	60	102	210,5	52	257	7
65	80	145	315	77	340,5	16,6	60	115	247,5	53,8	290,5	11,3
80	80	145	315	77	343,5	17,4	60	115	247,5	53,8	293,5	12,1
100	80	157	345	82	366,5	24	60	127	268,5	67	316,5	17,2
125	80	177	408,5	91,5	434,5	37,6	80	157	345	82	414,5	26,2
150	80	177	408,5	91,5	444	40,6	80	157	345	82	424	34
200	80	220,5	487	105	516,5	72,3	80	177	408,5	961,5	473	55,2
250	80	245	543	112	567	109	80	196	437,5	99	518	84,8

DN	A	B	C	D	E	F	G	H2
25	25	20	85	85	50	26	75	45
40	41	32	92	92	58	31	96	45
50	53	40	95	95	71	38	112	45
65	65	50	115,5	115,5	85	49	129	55
80	80	65	118,5	118,5	95	55	142	55
100	100	80	129,5	129,5	112	62	174	55
125	100	125	177,5	177,5	148	85	200	55
150	150	120	187	187	170	95	220	55
200	200	155	216	216	210	120	275	75
250	250	195	242	242	270	145	338	75

Dimensions in mm

Dimensions KS2 without actuator (with mounting kit ISO 5211)

Sealing of the bearing shaft with PTFE-packing

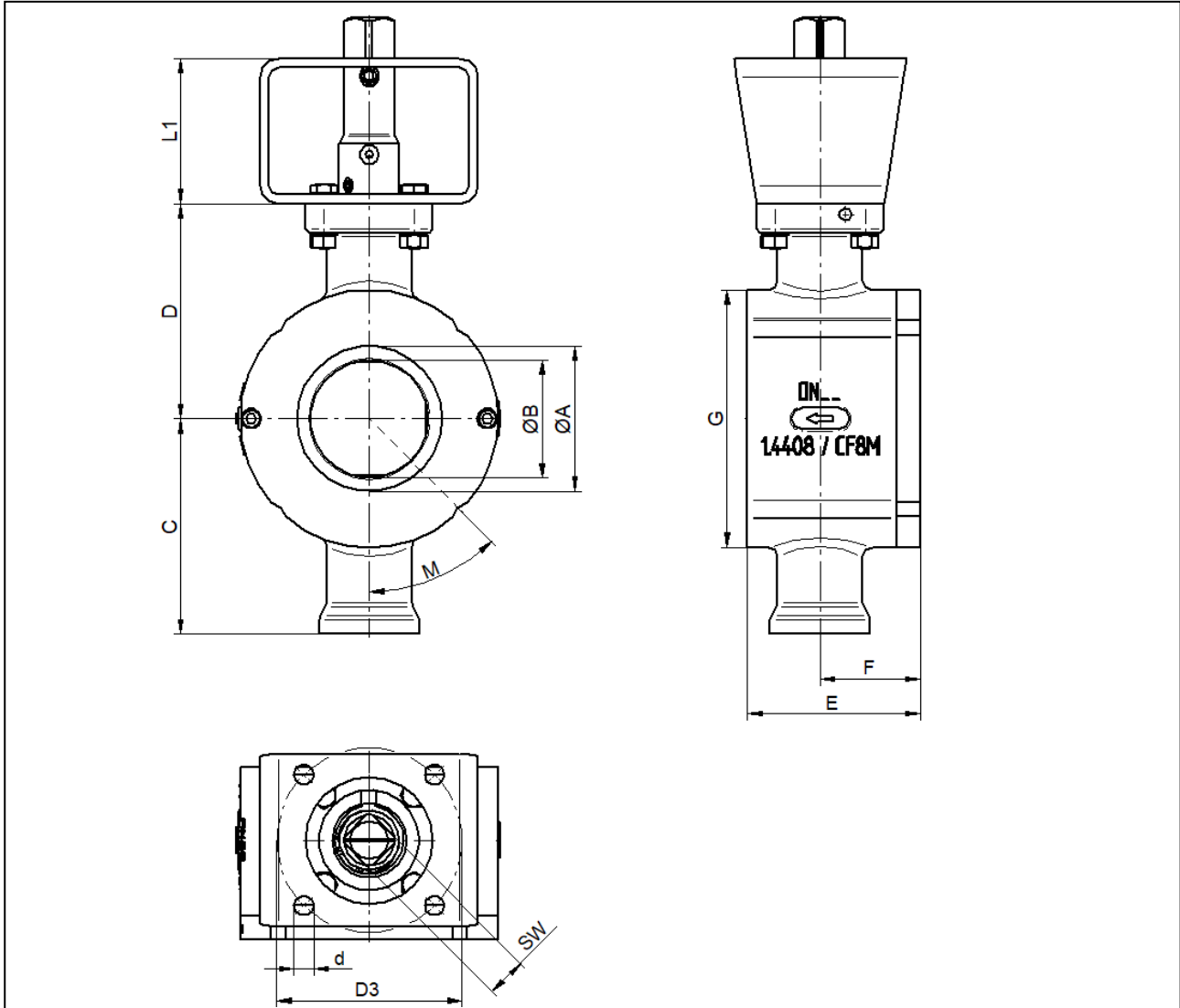

DN	A	B	C	D	E	F	G	series 1				series 2				weight [kg]		
								L1	SW	d	D3	DIN ISO 5211	L1	SW	d		D3	DIN ISO 5211
25	25	20	85	85	50	26	75	60	11	5,5	42	F 04	60	14	6,6	50	F 05	2,2
40	41	32	92	92	58	31	96	60	14	6,6	50	F 05	60	17	9	70	F 07	3
50	53	40	95	95	71	38	112	60	14	6,6	50	F 05	60	17	9	70	F 07	3,8
65	65	50	115,5	115,5	85	49	129	60	17	9	70	F 07	80	22	11	102	F 10	6,4
80	80	65	118,5	118,5	95	55	142	60	17	9	70	F 07	80	22	11	102	F 10	7,2
100	100	80	129,5	129,5	112	62	174	60	17	9	70	F 07	80	22	11	102	F 10	11
125	100	125	177,5	177,5	148	85	200	80	22	11	102	F 10	80	27	13,5	125	F 12	20
150	150	120	187	187	170	95	220	80	22	11	102	F 10	80	27	13,5	125	F 12	23
200	200	155	216	216	210	120	275	80	27	13,5	125	F 12	80	36	17	140	F 14	40
250	250	195	242	242	270	145	338	80	27	13,5	125	F 12	80	36	17	140	F 14	66

Dimensions in mm

Dimensions KS2 without actuator version with square shaft

Sealing of the bearing shaft with PTFE-packing

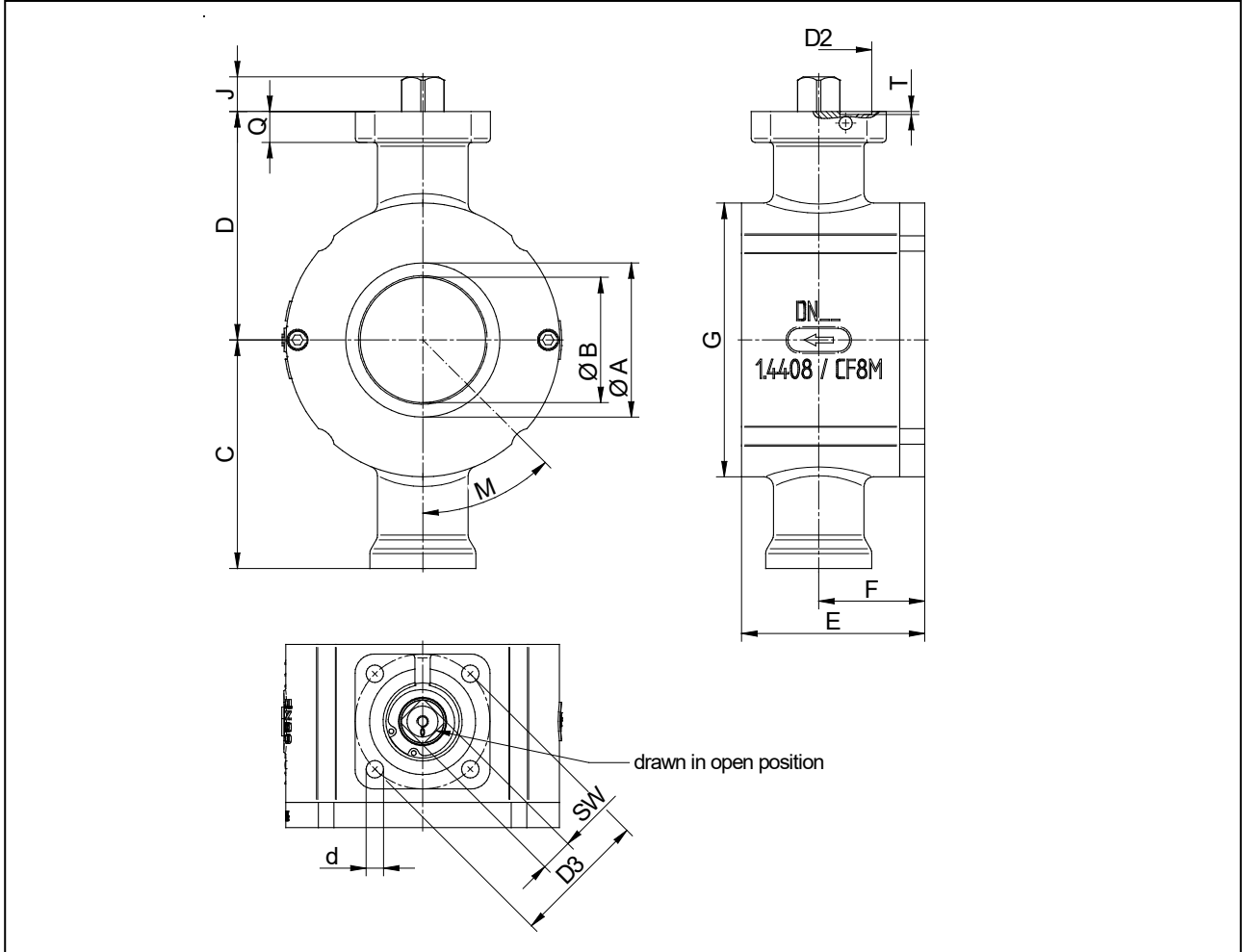

DN	A	B	C	D	E	F	J	SW	Q	d	D2	T	D3	DIN ISO 5211	Weight [kg]
25	25	20	85	85	50	26	15	14	11	6,6	35	1	50	F 05	2,2
40	41	32	92	92	58	31	15	14	11	6,6	35	1	50	F 05	3
50	53	40	95	95	71	38	15	14	11	6,6	35	1	50	F 05	3,8
65	65	50	115,5	115,5	85	49	18	17	16	9	55	1,5	70	F 07	6,4
80	80	65	118,5	118,5	95	55	18	17	16	9	55	1,5	70	F 07	7,2
100	100	80	129,5	129,5	112	62	18	17	16	9	55	1,5	70	F 07	11
125	100	125	177,5	177,5	148	85	22,5	22	17	11	70	1,5	102	F 10	20
150	150	120	187	187	170	95	22,5	22	17	11	70	1,5	102	F 10	23
200	200	155	216	216	210	120	27,5	27	17	13,5	85	1,5	125	F 12	40
250	250	195	242	242	270	145	27,5	27	17	13,5	85	1,5	125	F 12	66

Dimensions in mm

Dimensions KS2 with stem extension and hand lever

Sealing of the bearing shaft with PTFE-packing

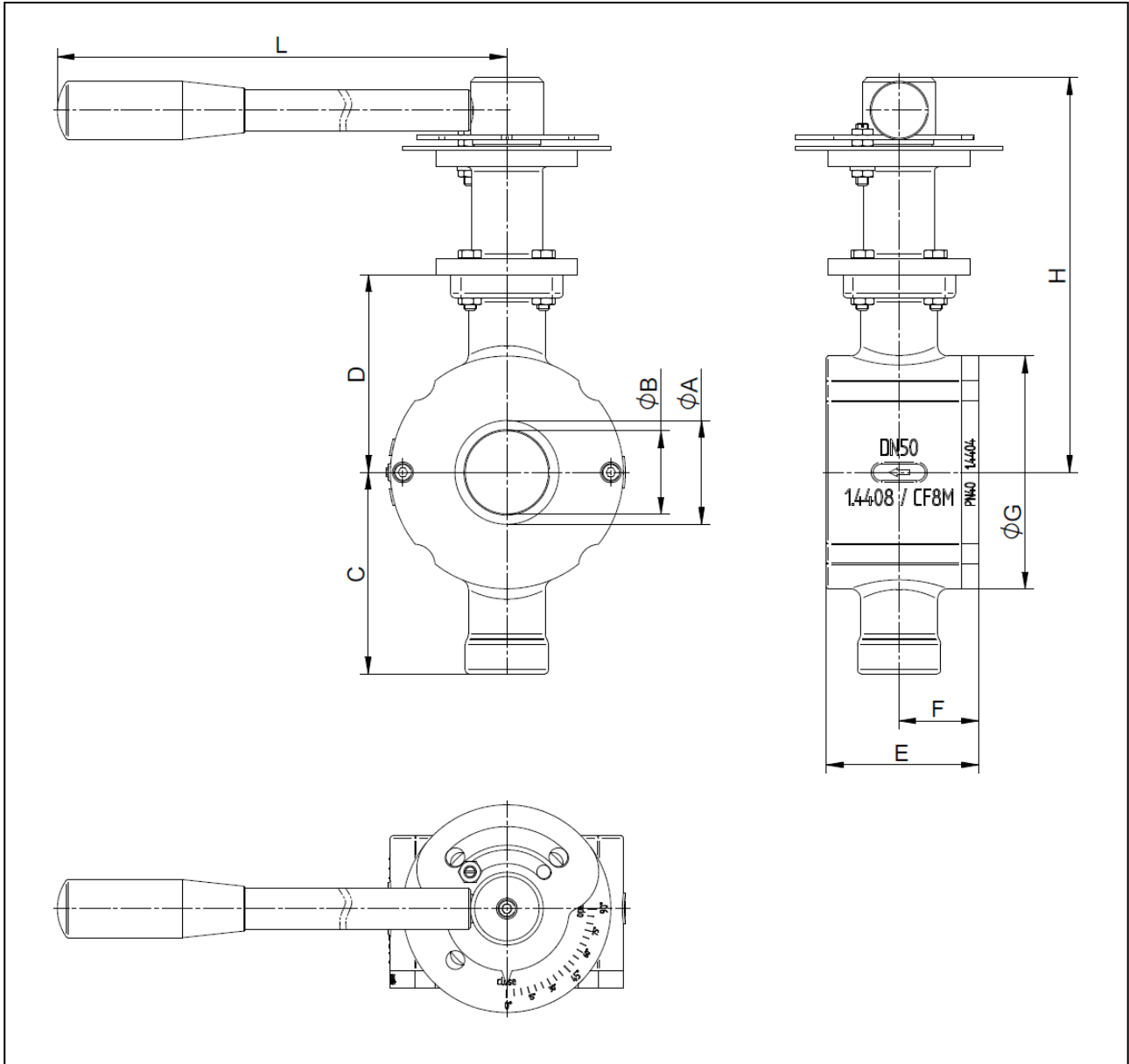

DN	A	B	C	D	E	F	G	H	L	Weight (kg)
25	25	20	85	85	50	26	73	180	254	3,7
40	41	32	92	92	58	31	94	187	254	4,5
50	53	40	95	95	71	38	112	190	254	5,3
65	65	50	116	116	85	49	112	231	254	8,8
80	80	65	119	119	95	55	142	234	325	9,6
100	100	80	130	130	112	62	174	245	325	13,4

Dimensions in mm

Dimensions KS2 with stem extension and hand wheel gearbox

Sealing of the bearing shaft with PTFE-packing

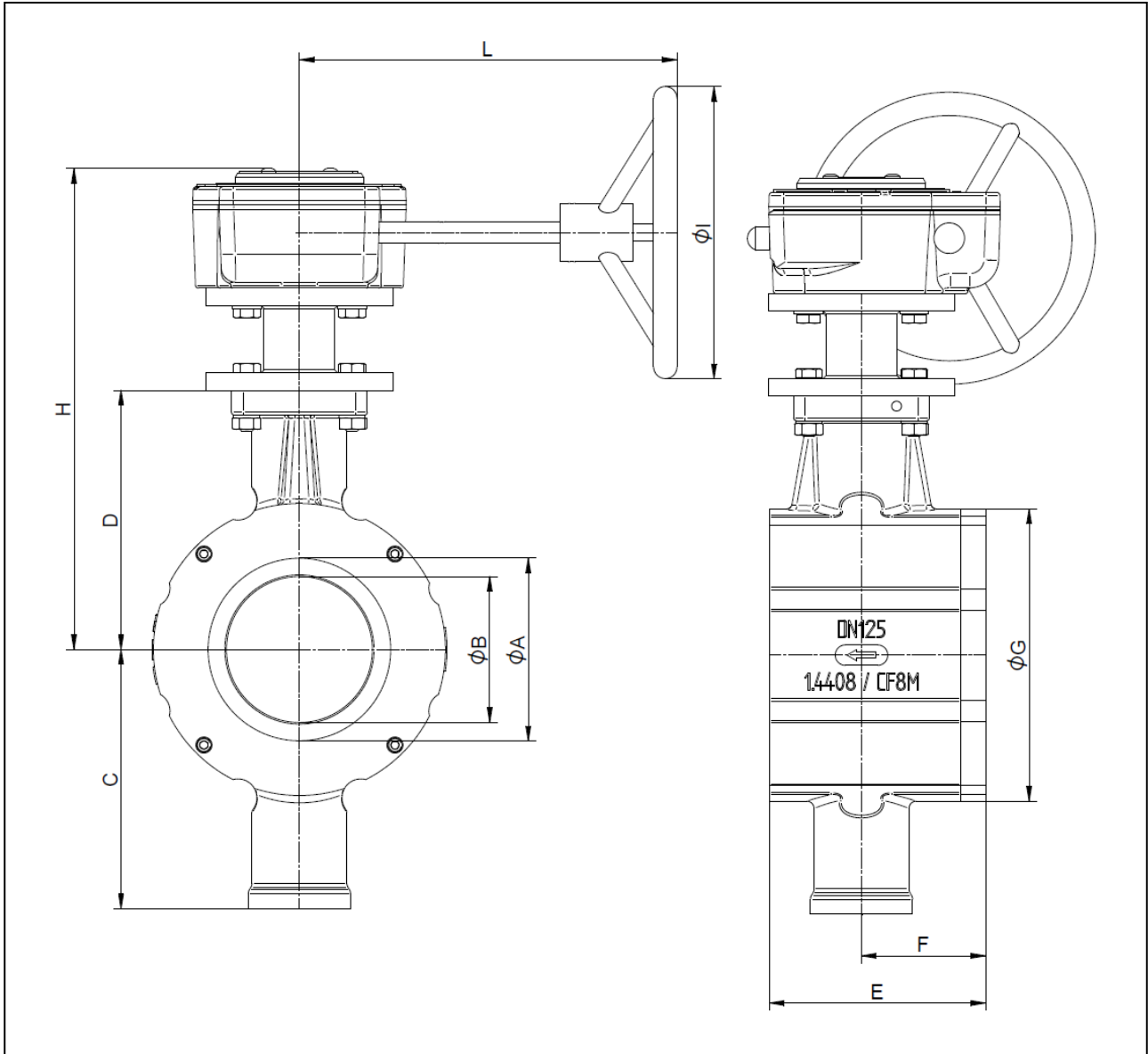

DN	A	B	C	D	E	F	G	H	I	L	Weight (kg)
125	125	100	178	178	148	85	200	330	200	259	28
150	150	120	187	187	170	95	220	339	200	259	31
200	200	155	216	216	210	120	275	358	200	259	49,2
250	250	195	242	242	270	145	344	384	200	259	75,2

Dimensions in mm

Dimensions KS2 without actuator version with dihedron

Sealing of the bearing shaft with PTFE-packing

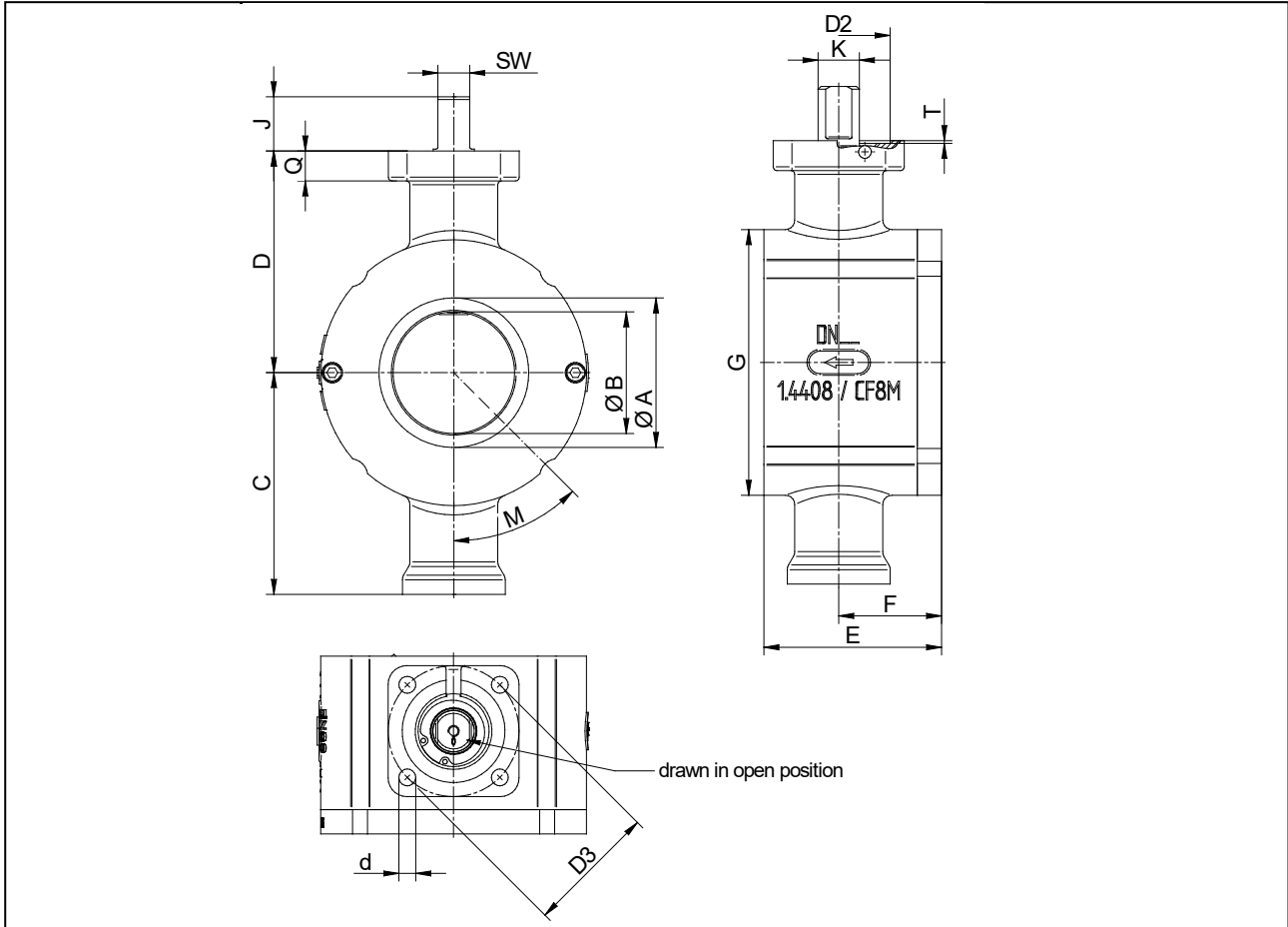

DN	A	B	C	D	E	F	J	SW	K	Q	d	D2	T	D3	DIN ISO 5211	weight [kg]
25	25	20	85	85	50	26	24	14	18	11	6,6	35	1	50	F 05	2,2
40	41	32	92	92	58	31	24	14	18	11	6,6	35	1	50	F 05	3
50	53	40	95	95	71	38	24	14	18	11	6,6	35	1	50	F 05	3,8
65	65	50	115,5	115,5	85	49	29	17	22	16	9	55	1,5	70	F 07	6,4
80	80	65	118,5	118,5	95	55	29	17	22	16	9	55	1,5	70	F 07	7,2
100	100	80	129,5	129,5	112	62	29	17	22	16	9	55	1,5	70	F 07	11
125	100	125	177,5	177,5	148	85	37,5	22	28	17	11	70	1,5	102	F 10	20
150	150	120	187	187	170	95	37,5	22	28	17	11	70	1,5	102	F 10	23
200	200	155	216	216	210	120	46,5	27	36	17	13,5	85	1,5	125	F 12	40
250	250	195	242	242	270	145	46,5	27	36	17	13,5	85	1,5	125	F 12	66

Dimensions in mm

Dimensions KS1 DN300 with AirTorque actuator

sealing of the ball sector with O-rings
(designed for a pilot pressure of 5 - 6 bar)

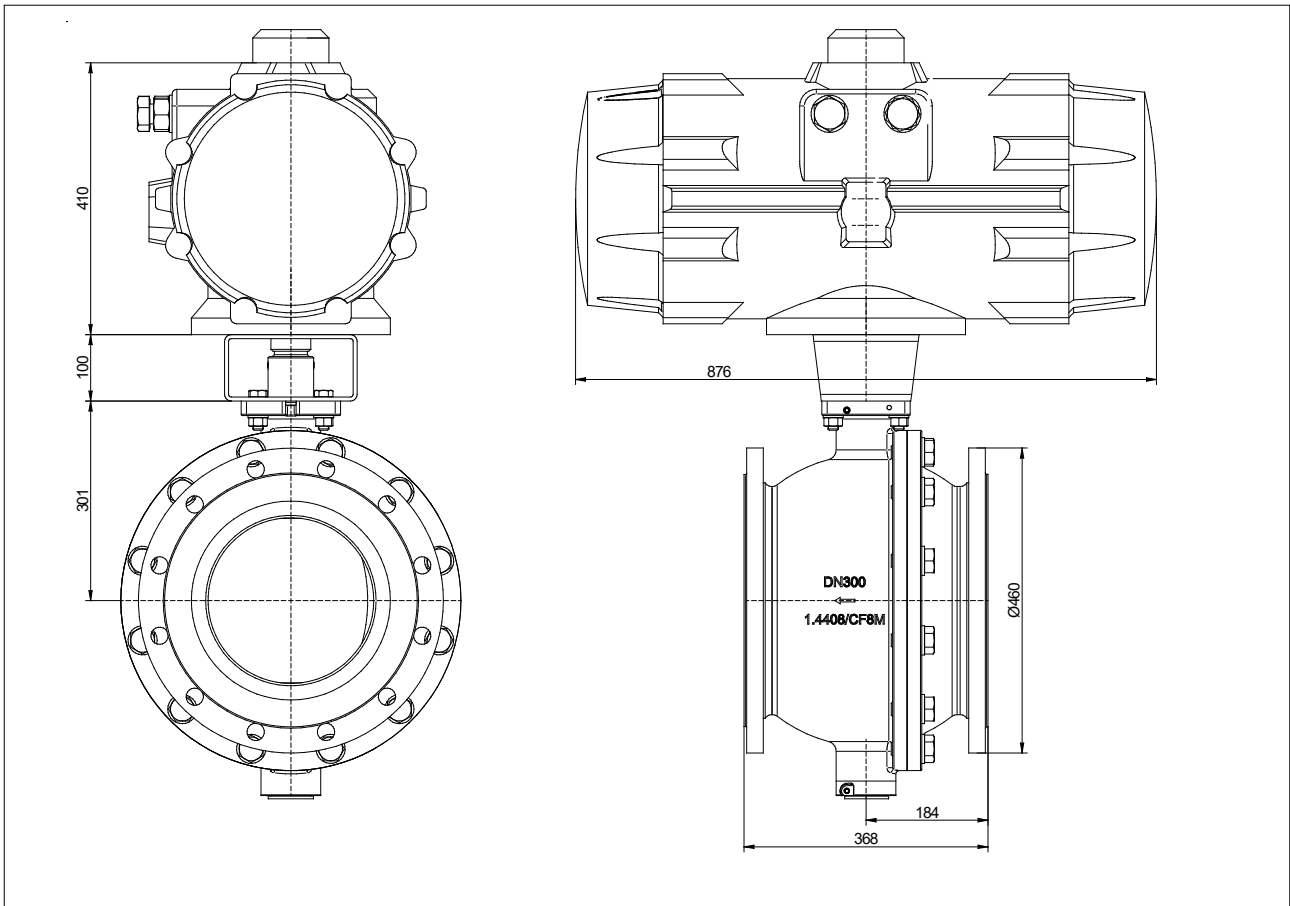

Dimension in mm