

# G50 Series

## 45 bar Compressed Air Filters

Grade ZP General Purpose & Grade XP  
High Efficiency Coalescing & Dry Particulate Filters  
Grade A Oil Vapour Reduction Filter (¼" - 2")

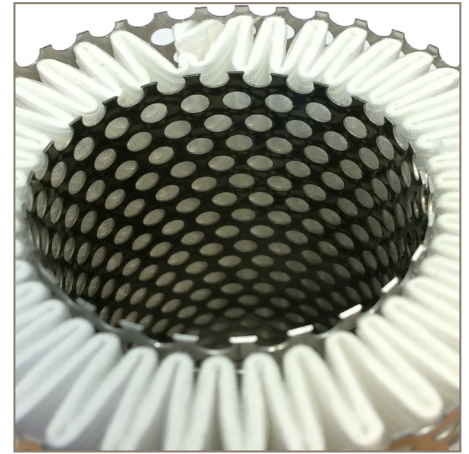

### High Pressure Compressed Air Filters

Compressed air contains 10 contaminants (emanating from 4 sources) which must be treated and reduced to acceptable levels for the compressed air system to operate safely, efficiently and cost effectively.

Most industrial compressed air applications operate at pressures around 7, 10 or 13 bar g and purification equipment is typically designed around these operating pressures. There are however, applications that require higher operating pressures (which also leads to increased concentration of many contaminants).

### Parker G50 Series Intermediate Pressure Filters

The Parker G50 Series Intermediate Pressure filter range is available in multiple filtration grades to cover all filtration requirements, including general purpose and high efficiency coalescing grades, general purpose and an oil vapour reduction grade.



### Advantages

- Meets the requirements for delivered air quality shown in all editions of ISO8573-1, the international standard for compressed air quality.
- Pleated filter element – Coalescing and dry particulate filter media is constructed to reduce air flow velocity and pressure loss whilst providing increased dirt holding capacity, and improved filtration efficiency.
- Filter element is secured by tie-rod to ensure element is held in place, even with pressure pulsations commonly experienced with piston compressors.



ENGINEERING YOUR SUCCESS.

## Filtration Performance

Filtration Grade	Filter Type	Particle Reduction (inc water & oil aerosols)	Max Remaining Oil Content at 21°C (70°F)	Filtration Efficiency	Change Element Every	Precede with Filtration Grade
ZP	Coalescing & Dry Particulate	Down to 1 micron	0.5 mg/m <sup>3</sup> 0.5 ppm(w)	99.925%	12 months or 6000 hours	N/A
XP	Coalescing & Dry Particulate	Down to 0.01 micron	0.01 mg/m <sup>3</sup> 0.01 ppm(w)	99.9999%	12 months or 6000 hours	ZP
A	Oil Vapour Reduction	N/A	0.003 mg/m <sup>3</sup> 0.003 ppm(w)	N/A	When oil vapour is detected	ZP+XP

### Important Note:

Using the same filter housings as their coalescing and dry particulate counterparts, Grade A filter elements differ in that they utilise a bed of activated carbon to adsorb oil vapour. It is important to note, in-line adsorption filter elements have a different life span compared to coalescing and dry particulate filters and require more frequent element changes.

## Technical Data

Filtration Grade	Filter Models	Min Operating Pressure		Max Operating Pressure		Min Operating Temperature		Max Operating Temperature*	
		bar g	psi g	bar g	psi g	°C	°F	°C	°F
ZP/XP	G2/50 - G14/50	20	290	45	653	2	35	80	176
A	G2/50 - G14/50	20	290	45	653	2	35	50	122

\*Note: recommended max. operating temperature for activated carbon filter is +40°C.

## Flow Rates

Model	Pipe Size	l/s	m <sup>3</sup> /min	m <sup>3</sup> /hr	cfm	Replacement Element	No.
G2/50	Grade ¼"	20.8	1.3	75	44	1030	1
G3/50	Grade ¼"	34.7	2.1	125	74	1050	1
G5/50	Grade ⅜"	48.6	2.9	175	103	1070	1
G7/50	Grade ½"	69.4	4.2	250	147	1140	1
G9/50	Grade ¾"	125.0	7.5	450	265	2010	1
G11/50	Grade 1"	208.3	12.5	750	441	2020	1
G12/50	Grade 1½"	326.4	19.6	1175	692	2030	1
G13/50	Grade 1½"	486.1	29.2	1750	1030	2050	1
G14/50	Grade 2"	722.2	43.3	2600	1530	3050	1

Stated flows are for operation at 45 bar (g) (653 psi g) with reference to 20°C, 1 bar (a), 0% relative water vapour pressure. For flows at other pressures, apply the correction factors shown below.

## Product Selection & Correction Factors

To correctly select a filter model, the flow rate of the filter must be adjusted for the minimum operating (inlet) pressure at the point of installation.

1. Obtain the minimum operating (inlet) pressure and maximum compressed air flow rate at the inlet of the filter.
2. Select the correction factor for minimum inlet pressure from the CFMIP table (always round down e.g. for 38 bar, use 35 bar correction factor)
3. Calculate the minimum filtration capacity. Minimum Filtration Capacity = Compressed Air Flow Rate x CFMIP
4. Using the minimum filtration capacity, select a filter model from the flow rate tables above (filter selected must have a flow rate equal to or greater than the minimum filtration capacity).

## CFMIP - Correction Factor Minimum Inlet Pressure

Minimum Inlet Pressure	bar g	20	25	30	35	40	45
	psi g	290	362	435	508	580	652
Correction Factor		2.43	1.96	1.65	1.41	1.24	1.10

## Filter coding example

Grade	Model
XP	G2/50XP

## Filtration Tested In Accordance With

Filtration Grade	ZP	XP	A
Filter Type	Coalescing & Dry Particulate	Coalescing & Dry Particulate	Oil Vapour Reduction
Test Methods Used	Not Applicable	Not Applicable	Not Applicable
Inlet Challenge Concentration	Not Applicable	Not Applicable	Not Applicable

## Weight & Dimensions

Model	H		W		D		C		Weight	
	mm	ins	mm	ins	mm	ins	mm	ins	kg	lbs
G2/50	200	7.9	61	2.4	14	0.6	60	2.4	0,8	1.7
G3/50	245	9.6	87	3.4	21	0.8	75	3.0	1,2	2.7
G5/50	245	9.6	87	3.4	21	0.8	90	3.5	1,2	2.7
G7/50	315	12.4	87	3.4	21	0.8	160	6.3	1,4	3.1
G9/50	350	13.8	130	5.1	43	1.7	135	5.3	4,1	9.1
G11/50	450	17.7	130	5.1	43	1.7	235	9.3	4,9	10.9
G12/50	525	20.7	130	5.1	43	1.7	335	13.2	5,0	11.1
G13/50	755	29.7	130	5.1	43	1.7	525	20.7	6,6	14.6
G14/50	735	28.9	164	6.5	48	1.9	520	20.5	8,9	19.7

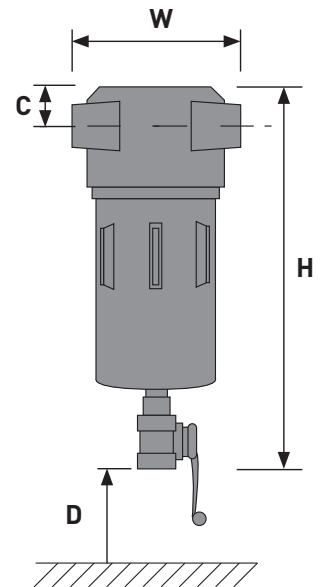

## Quality Assurance / IP Rating / Pressure Vessel Approvals

Development / Manufacture	ISO 9001 / ISO 14001
Ingress Protection Rating	Not Applicable
EU	Pressure vessel approved for fluid group 2 in accordance with the Pressure Equipment Directive 2014/68/EU
USA	-
For use with Compressed Air Only	

# Parker Worldwide

## Europe, Middle East, Africa

### AE – United Arab Emirates,

Dubai

Tel: +971 4 8127100

### AT – Austria, St. Florian

Tel: +43 (0)7224 66201

### AZ – Azerbaijan, Baku

Tel: +994 50 2233 458

### BE/NL/LU – Benelux,

Hendrik Ido Ambacht

Tel: +31 (0)541 585 000

### BY – Belarus, Minsk

Tel: +48 (0)22 573 24 00

### CH – Switzerland, Etoy

Tel: +41 (0)21 821 87 00

### CZ – Czech Republic,

Prague

Tel: +420 284 083 111

### DE – Germany, Kaarst

Tel: +49 (0)2131 4016 0

### DK – Denmark, Ballerup

Tel: +45 43 56 04 00

### ES – Spain, Madrid

Tel: +34 902 330 001

### FI – Finland, Vantaa

Tel: +358 (0)20 753 2500

### FR – France, Contamine s/Arve

Tel: +33 (0)4 50 25 80 25

### GR – Greece

Tel: +30 69 44 52 78 25

### HU – Hungary, Budaörs

Tel: +36 23 885 470

### IE – Ireland, Dublin

Tel: +353 (0)1 466 6370

### IL – Israel

Tel: +39 02 45 19 21

### IT – Italy, Corsico (MI)

Tel: +39 02 45 19 21

### KZ – Kazakhstan, Almaty

Tel: +7 7273 561 000

### NO – Norway, Asker

Tel: +47 66 75 34 00

### PL – Poland, Warsaw

Tel: +48 (0)22 573 24 00

### PT – Portugal

Tel: +351 22 999 7360

### RO – Romania, Bucharest

Tel: +40 21 252 1382

### RU – Russia, Moscow

Tel: +7 495 645-2156

### SE – Sweden, Borås

Tel: +46 (0)8 59 79 50 00

### SL – Slovenia, Novo Mesto

Tel: +386 7 337 6650

### TR – Turkey, Istanbul

Tel: +90 216 4997081

### UK – United Kingdom, Warwick

Tel: +44 (0)1926 317 878

### ZA – South Africa, Kempton

Park

Tel: +27 (0)11 961 0700

## North America

### CA – Canada, Milton, Ontario

Tel: +1 905 693 3000

### US – USA, Cleveland

Tel: +1 216 896 3000

## Asia Pacific

### AU – Australia, Castle Hill

Tel: +61 (0)2-9634 7777

### CN – China, Shanghai

Tel: +86 21 2899 5000

### HK – Hong Kong

Tel: +852 2428 8008

### IN – India, Mumbai

Tel: +91 22 6513 7081-85

### JP – Japan, Tokyo

Tel: +81 (0)3 6408 3901

### KR – South Korea, Seoul

Tel: +82 2 559 0400

### MY – Malaysia, Shah Alam

Tel: +60 3 7849 0800

### NZ – New Zealand, Mt

Wellington

Tel: +64 9 574 1744

### SG – Singapore

Tel: +65 6887 6300

### TH – Thailand, Bangkok

Tel: +662 186 7000

### TW – Taiwan, Taipei

Tel: +886 2 2298 8987

## South America

### AR – Argentina, Buenos Aires

Tel: +54 3327 44 4129

### BR – Brazil, Sao Jose dos

Campos

Tel: +55 080 0727 5374

### CL – Chile, Santiago

Tel: +56 22 303 9640

### MX – Mexico, Toluca

Tel: +52 72 2275 4200



### EMEA Product Information Centre

Free phone: 00 800 27 27 5374

(from AT, BE, CH, CZ, DE, DK, EE, ES, FI, FR, IE, IL, IS, IT, LU, MT, NL, NO, PL, PT, RU, SE, SK, UK, ZA)

### US Product Information Centre

Toll-free number: 1-800-27 27 537

[www.parker.com/gsf](http://www.parker.com/gsf)