

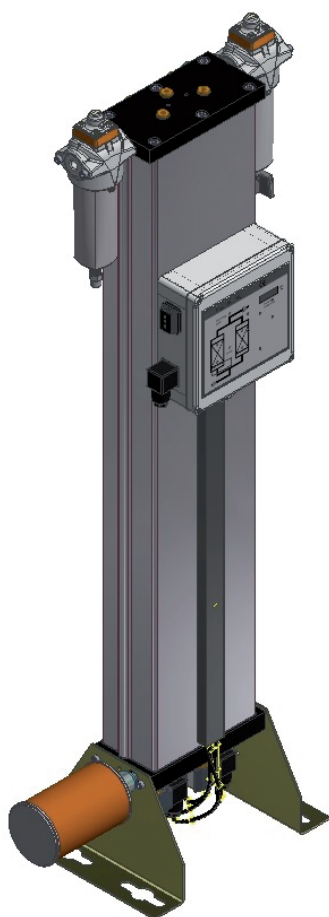

Adsorption dryer

K-MT 1-8/D3

(Generation - 3)



Operating manual

14/02/2022 - rev 03 EN

Cod: 398H272183

Index

Machine passport	3
General information	4
Manufacturer's details	4
Details on the dryer.....	4
About these operating instructions.....	5
For your own safety	6
General safety notes.....	6
Intended use of the dryer.....	7
Signs and hazard areas on the dryer	8
Transportation, installation and storage	10
Information on transportation packaging.....	10
What to do in the case of transport damage occurring?	10
Transporting and installing the dryer.....	11
Storing the dryer	13
Technical product description	14
Summary drawing.....	14
Function description	14
Available options.....	17
Installation	19
Preconditions for installation	19
Connect piping	20
Installing the electrical connection.....	21
Start-up	23
Requirements for initial start-up	23
Setting times of the operating phases	23
Overview of operating and control elements	24
Start up dryer.....	27
Changing cycle mode (optional)	29
Monitoring dryer operation	30
With dewpoint-sensing control (optional)	30
Shutdown and restart dryer	31
Emergency shutdown	31
Depressurising and shutting down the dryer	31
If work is to be carried out on the electrical system	32
Restart	32
Maintenance and repair of the dryer	33
Notes on maintenance.....	33
Regular maintenance intervals.....	34
Instructions for use of the dongle	35
Daily maintenance tasks	35
Maintenance work to be completed every 12 months.....	36
Maintenance work to be completed every 24 months.....	38
Maintenance work to be completed every 48 months.....	38
Identify and eliminate faults	43
Summary of faults.....	43

Annex with technical documentation **46**

Technical data..... 47

Replacement and wear part list 48

Logic control diagram 49

Flow diagram 51

Dimensional drawing 52

Machine passport

It is the responsibility of the owner,

- ◇ to enter for the first time any appliance data not stated above,
- ◇ to keep these appliance data up to date.

The above-stated appliance data provide for a clear identification of the dryer and its components, and significantly facilitate any service measures.

Further important data on the dryer such as the details on the permissible operating pressure and the electrical connection are found on the type plate (for position of the type plate see page 8)

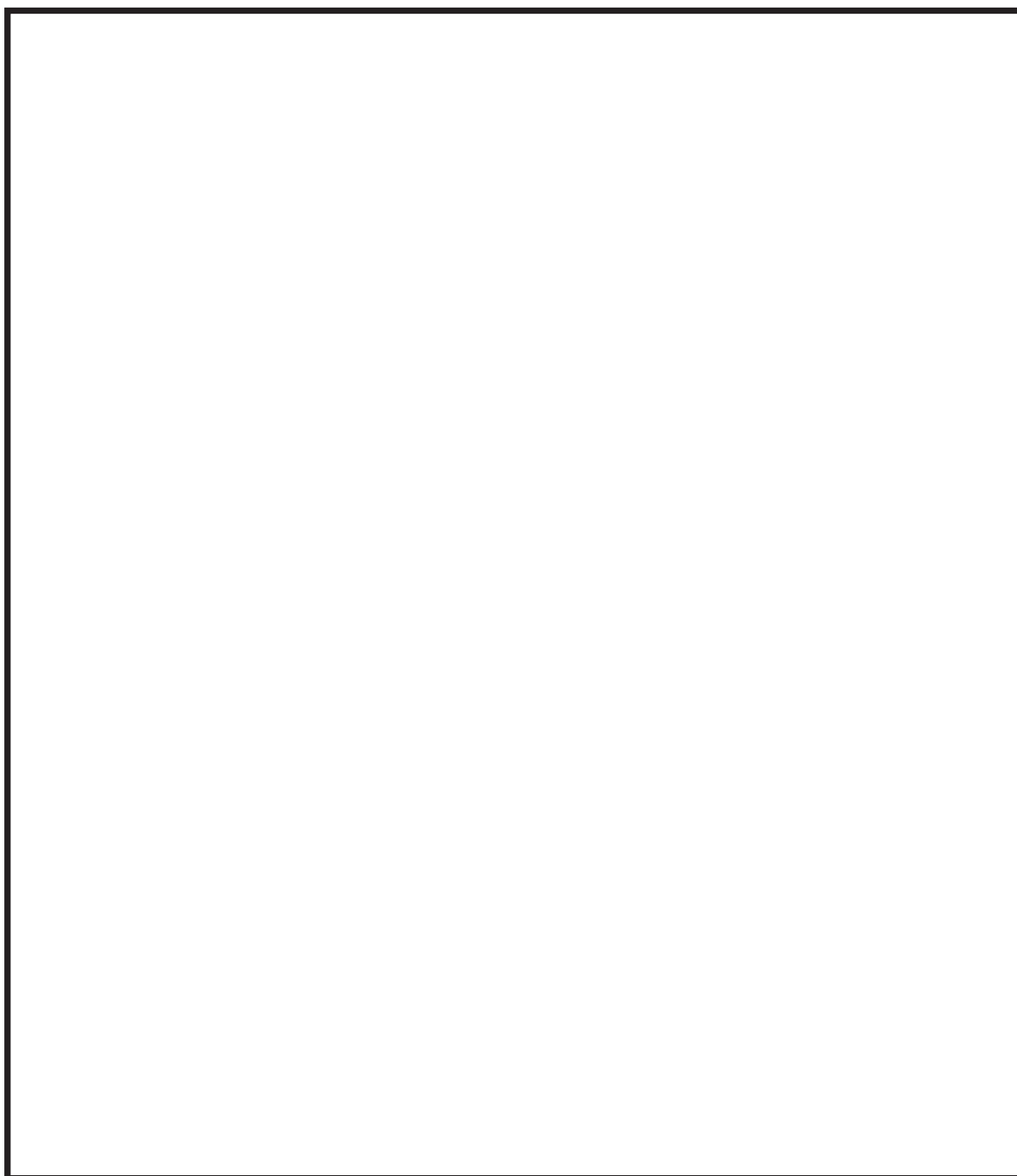

General information

Manufacturer's details

Name and address

Parker Hannifin Manufacturing S.r.l.

Sede Legale: Via Sebastiano Caboto 1, Palazzina "A" 20094 Corsico (MI) Italy

Sede Operativa: Gas Separation and Filtration Division EMEA - Strada Zona Industriale, 4
35020 S. Angelo di Piove (PD) Italy

tel +39 049 971 2111- fax +39 049 9701911

Web-site: www.parker.com/hzd

Details on the dryer

Standard equipment

Standard dryer*, consisting of:

- ◇ 2 vessels, filled with desiccant
- ◇ 1 upstream filter
- ◇ 1 downstream filter
- ◇ Piping and muffler
- ◇ Control system

Associated documents

- ◇ Operating instructions (present)
- ◇ Technical documentation (see annex)
- ◇ Circuit diagrams (see separate document)
- ◇ Operating manual for installed filters (separate document)

Notes on supplementary documents

Supplementary documents such as operating manuals for options or pertaining components must always be heeded. They contain additional information, e.g. regarding maintenance, and are therefore necessary for safe operation of the plant.

* Planned dryers may be equipped with special components.

About these operating instructions

These operating instructions contain basic information on the safe use of the dryer.

Characters and symbols used

► Work steps that you have to carry out in the sequence stated are marked by black triangles.

◇ Lists are marked by a small box

Note:

These notes provide you with hints and information on the safe and efficient handling of machines and devices.



Warning!

These safety notes warn against damage to property and help you to avoid such damage.



Danger!

These danger notes with a grey background warn against personal injury and/or danger to life and limb; danger notes help you to avoid serious or life-threatening situations for yourself and/or third parties.

Target group of these operating instructions

These operating instructions are intended for all persons working on and using the dryer. We assume that all such persons are specialist personnel, e.g. fitters or electricians.

Operating instructions: handling

These operating instructions must be continuously available at the site where the dryer is used. We recommend to prepare a copy and to keep the same in a safe and freely accessible place next to the dryer. Keep the original document in a safe place.

For your own safety

The dryer has been built in accordance with the state of the art and the recognized technical safety regulations. Nevertheless, there is a risk of personal injury and damage to property when the dryer is used, if

- ◇ it is operated by non-qualified personnel,
- ◇ not used within its intended design specifications,
- ◇ is repaired or maintained incorrectly.

Note:

For your own safety and to prevent machine damage, please note the information and safety notes in these operating instructions when working with the dryer.

General safety notes



Warning against sudden air ejection

When the hollow section vessels are depressurised, air flows suddenly out of the sound absorber.

- ◇ This causes a sudden loud cracking noise.
- ◇ Due to particles carried in the air flow, there is a very considerable risk of eye injury.

When working on the dryer, always wear eye and ear protection equipment.



Hazard due to a sudden release of pressure!

Never remove any parts of the dryer, or manipulate the same in any way, for as long as the plant is still pressurised! A sudden escape of pressure may cause serious injuries.

Before carrying out any work on the dryer, first depressurise the plant.



Risk of injury due to voltage-carrying parts!

The electrical supply cable and external power lines are live even after the dryer is switched off and, in the event of body contact, may cause serious injury! Before carrying out any work on the electrical system, the electrical supply cable and all external power lines must be made voltage-free!

Personnel qualification

Only authorized and qualified specialist personnel may be tasked with the work on the dryer described in these operating instructions.

Conversions and modifications

Without prior approval by the manufacturer, no conversions and modifications must be made to the dryer! Any non-approved modifications may restrict the operational safety of the dryer and cause damage to property or personal injury.

Handling drying agents

The drying agents used do not pose any risk to health. However, when filling and emptying the hollow section vessels with drying agents, increased dust generation may occur. Please comply with the following instructions:

- ◇ When filling drying agents, wear a dust mask and eye protection!
- ◇ If a spillage occurs, any spilt drying agent must be taken up immediately. There is a risk of skidding!

Disassembly and disposal

- ◇ Dispose all parts of the dryer, the drying agent, and all other operating materials in an environmentally safe way and in accordance with all current statutory regulations.



Equipment containing electrical components must be disposed separately collected with electrical and electronic waste according to local and currently legislation.

Intended use of the dryer

The dryer is exclusively intended for drying compressed air. Depending on defined input conditions, it dries compressed air for industrial use.

The dryer is designed for compressed air, which is free from aggressive water, oil, and solid matter constituents.

As standard, the dryer is intended to be sited within a building and protected against the weather.

The dryer may be operated only in accordance with the data on the type plate and in accordance with the contractual conditions.

Suspected misuse

The dryer must not be misused as a climbing aid! Pipes, valves, and similar fittings have not been designed for such loads. They could fracture, tear off, or become damaged in another way.

Signs and hazard areas on the dryer

Signs and labels

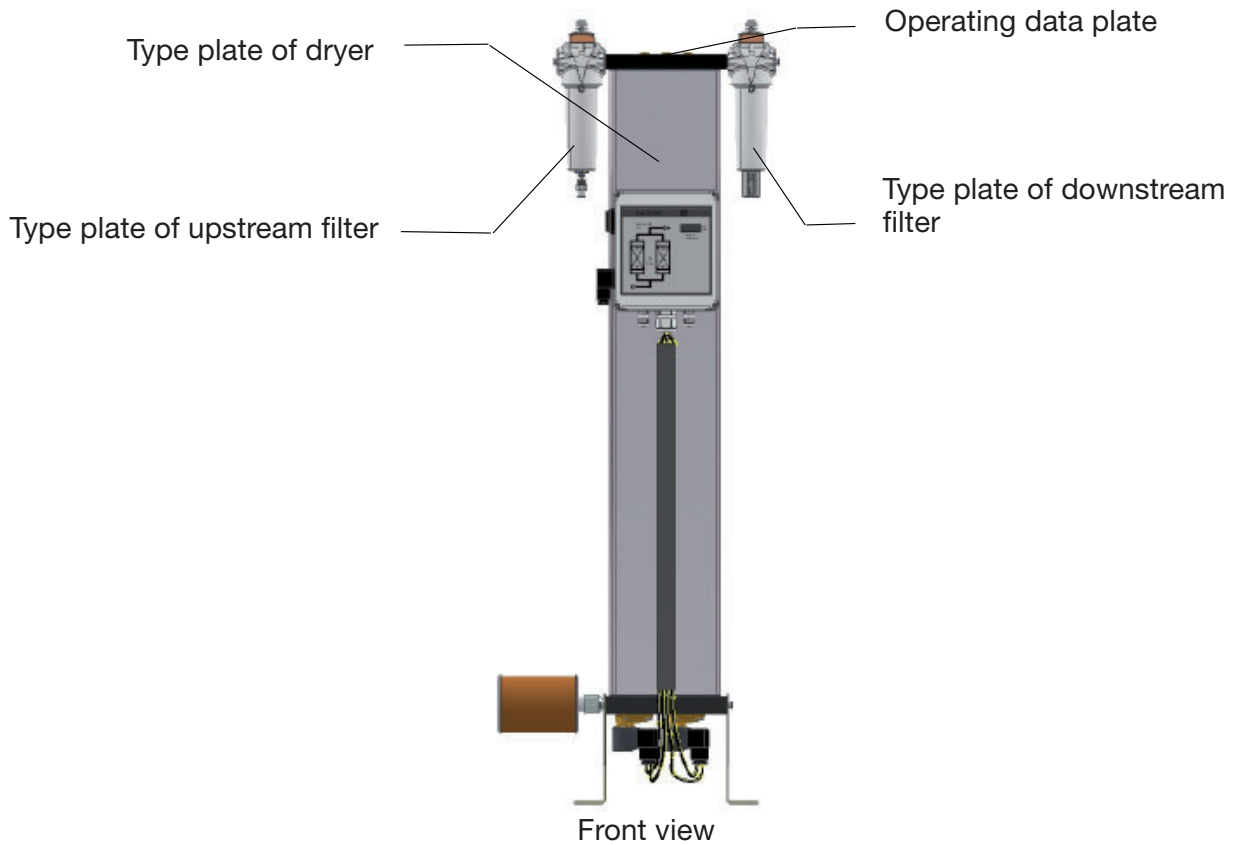

Please note the above plates and instructions attached to the dryer. Ensure that they are not removed and are always readable.

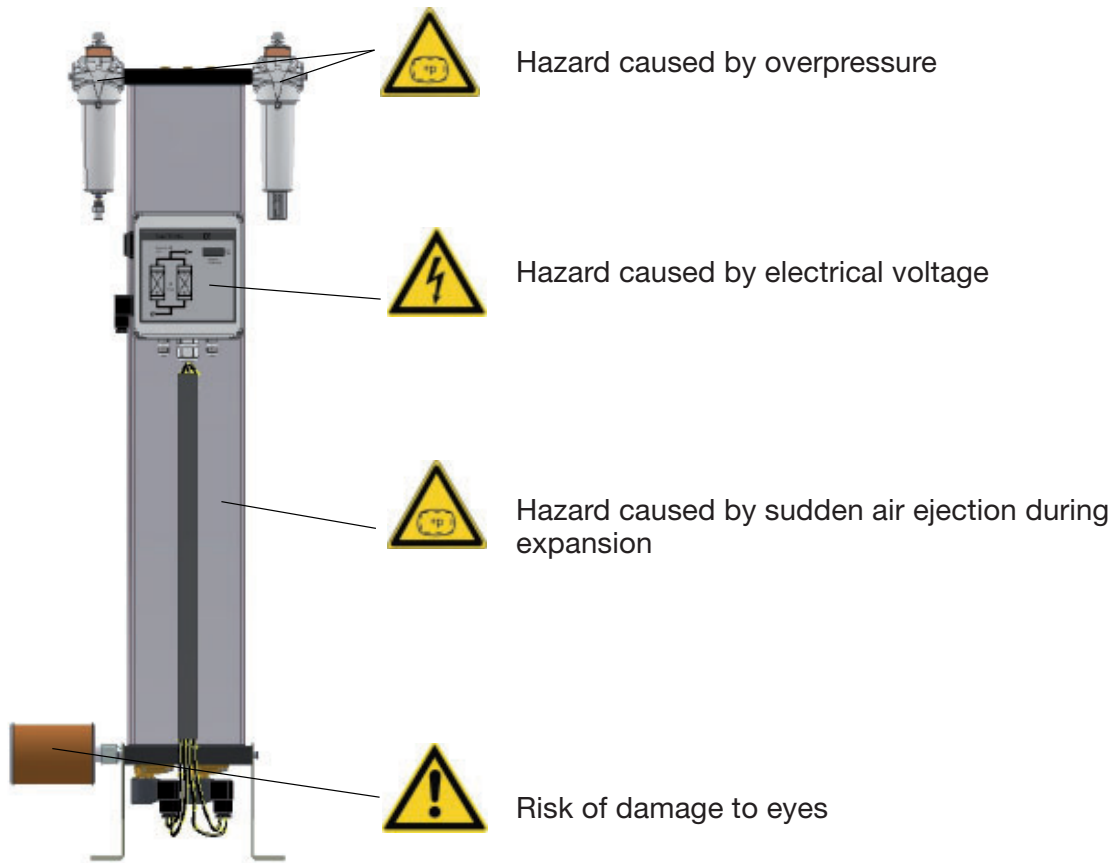

Symbol	Hazard area
	<p>Warning against hazardous electrical voltage</p> <p>Different parts of the dryer carry electrical current. These parts may be connected, opened, and maintained by authorized specialist personnel only.</p>
	<p>Warning against overpressure</p> <p>The entire dryer is under pressure. Before commencing any work, the plant must be depressurised.</p>
	<p>Warning against sudden air ejection</p> <p>When the vessels are depressurised, air flows suddenly out of the sound absorber:</p> <ul style="list-style-type: none"> ◇ This causes a sudden loud cracking noise. ◇ Due to particles carried in the air flow, there is a very considerable risk of eye injury. <p>When working on the dryer, always wear eye and ear protection equipment.</p>
	<p>Skid risk</p> <p>When emptying and filling the vessels with drying agent, there is a risk of skidding caused by spilt drying agent.</p>

Transportation, installation and storage



Danger due to incorrect transportation!

The dryer must be transported by authorized and qualified specialist personnel only. During transportation all applicable national regulations for accident prevention must be complied with. Otherwise there is a risk of personal injury. Always adhere to the stickers and notes on the packaging of the dryer!

- ◇ Only use suitable and technically perfect lifting gear with a sufficient carrying capacity. During transportation the dryer must be carefully secured against falling over. The manufacturer will not be liable for any damage caused by incorrect storage or incorrect transportation. Please note therefore the following instructions as well as the storage instructions on page 13.

Information on transportation packaging

Depending on the type of transportation, the dryer is delivered in different types of packaging:

- ◇ All transportation types: the apertures of the dryer are closed off by means of plugs.
- ◇ In addition, when transportation is effected by air: the dryer is packaged in a wooden box.
- ◇ In addition, when transportation is effected by ship: the dryer is packaged in a film material and in a wooden box.

If the packaging is undamaged

- ▶ The undamaged packaging should be removed only at the final installation site, as it offers protection against any weather influences.

What to do in the case of transport damage occurring?

- ▶ Check whether only the packaging or the dryer itself were damaged.
- ▶ Inform the haulier immediately in writing of any damages.
- ▶ Contact the manufacturer urgently in order to report the damage.



Warning!

A damaged dryer must not be taken into operation! Damaged components may lead to functional faults and possibly cause further damage.

Transporting and installing the dryer

Requirements for the installation site

The conditions at the installation site have a large influence on the functional capability of the dryer and the service life of the drying agent. In order to ensure a mode of operation, which is as continuous as possible, and low maintenance, the installation site must meet the following requirements:

- ◇ The installation site must be located within a building. Protect the dryer against moisture.
- ◇ The ambient temperature must not drop below +1,5 °C (34,7 °F).
- ◇ Heed the dryer's noise emission when selecting the installation location.
- ◇ The installation area must be level, firm and vibration-proof. It must have the necessary carrying capacity for the weight of the dryer. The weight of the dryer is specified in the technical data section of the annex.
- ◇ The dryer should be installed with sufficient spacing at the top, sides, and rear, in order to be able to carry out maintenance work and change the drying agent without any hindrances (see figure).

If in doubt, the installation site must be inspected by specialists. If you have any queries in this regard, please contact the manufacturer (see pag. 4

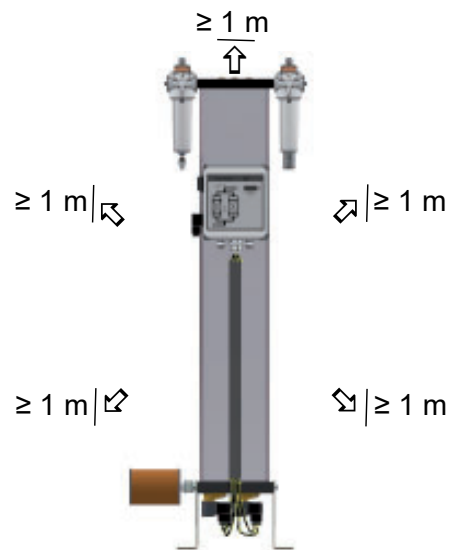

Necessary spacing at the top and sides
= min. 1 m

Transporting and installing the dryer



Warning against damage to property!

The dryer is delivered standing on its side on a transportation pallet. Top and sides have not been designed for mechanical loads. Therefore do not place any load onto the top face. Do not stack.

Therefore, always transport the dryer on a lifting or forklift truck.

The dryer should only be transported in an upright position.

- ▶ Secure the dryer on the lifting or forklift truck against sliding movements.
- ▶ Transport the dryer to its installation site.

- ▶ Secure the cardboard box or pallet on the lifting or forklift truck against sliding movements.
- ▶ Transport the dryer to its installation site.
- ▶ Remove the packaging of the dryer
- ▶ Carefully place the dryer in an upright position.
- ▶ Place the dryer at its installation site.

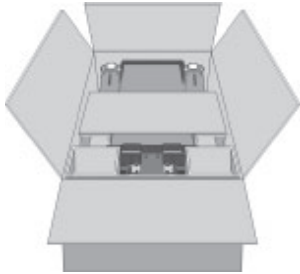

Dryer in the box

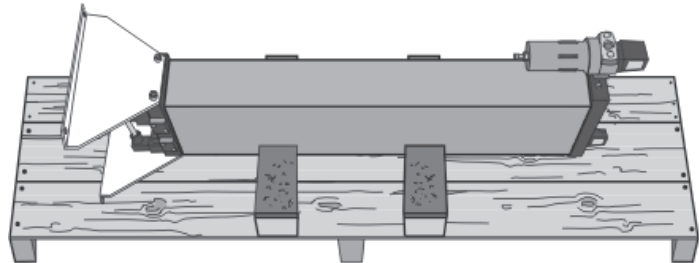

Dryer on pallet

Anchor dryer to the floor

The upright stand profiles of the dryer are provided with pre-drilled anchorage bores (see figure).

- ▶ Use suitable attachment material to anchor the dryer to the floor.
- ▶ In the case of vibrating floors: place the dryer on suitable vibration dampers.

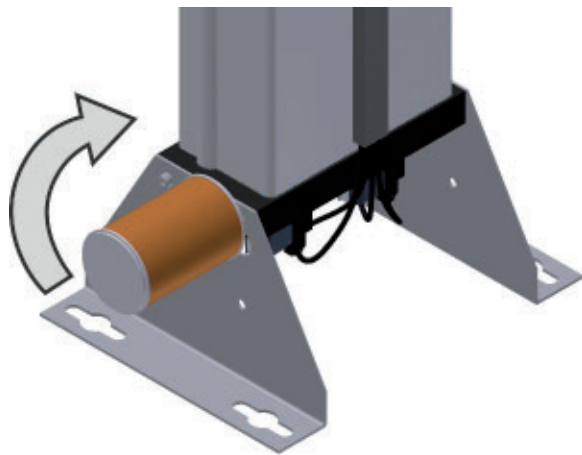

Bores on the stand profiles

Mount dryer on the wall

The stand profiles can be rotated by 90° towards the rear side of the dryer and secured in this position (see arrow in above figure).

- ▶ Remove the screws at the muffler and the stand profiles. Rotate the stand profiles by 90° until the auxiliary holes for the securing screws and the muffler are aligned with each other. Retighten the screws securing the stand profile and the muffler.
- ▶ Use suitable attachment material of sufficient carrying force to anchor the dryer to the wall.

Storing the dryer

If the dryer is to be stored for an extended period of time, the storage location must meet the following conditions:

- ◇ The dryer must not be stored in the open air.
- ◇ The storage room must be dry.
- ◇ The storage room must be free from dust or the dryer must be covered by a protective sheet.
- ◇ The storage room must have an ambient temperature of at least +1 °C (33,8 °F).

In order to store the dryer proceed as follows:

- ▶ Take dryer out of operation as described on page 31.
- ▶ Ensure that the compressed air inlet valve installed by the owner, and the installed compressed air outlet valve installed by the owner, are both closed, and that the dryer is depressurised.
- ▶ Disconnect dryer from the compressed air system.
- ▶ Disconnect the dryer from the electrical power supply and all external lines.
- ▶ Use film material or similar to close the compressed air inlet apertures and compressed air outlet apertures on the dryer in order to protect them against contamination.
- ▶ If possible cover dryer with a protective sheet.

The dryer can now be stored for long periods.

Note:

If you wish to take the dryer back into service after an extended period of storage, please proceed as described for its first commissioning and start-up (see page 27).

Store drying agents

- ▶ Do not store drying agents in the open air.
- ▶ Protect drying agents against humidity.

Technical product description

Summary drawing

Front view

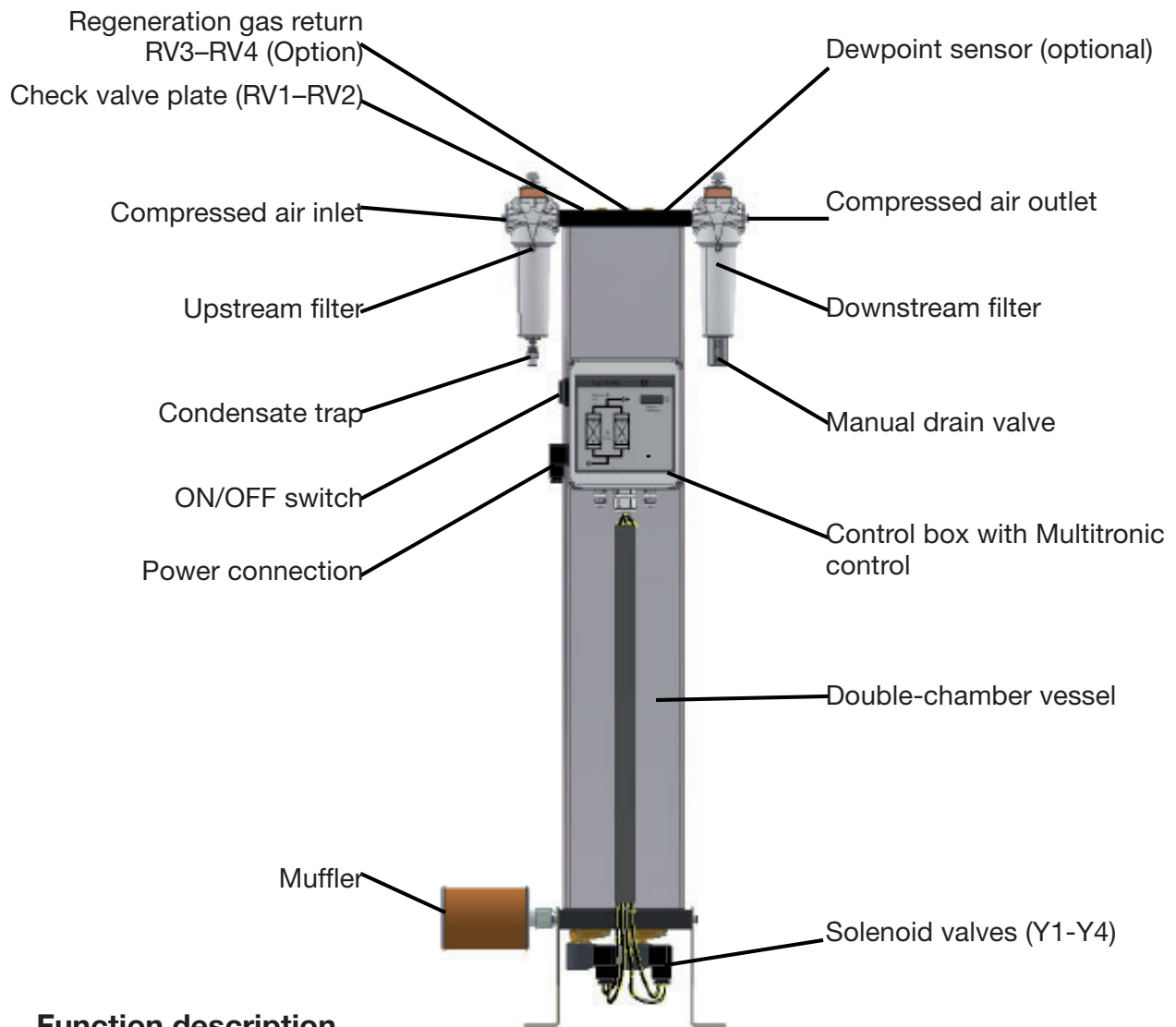

Function description

The dryer dries the compressed air supplied by the compressor and makes it available for industrial use.

Upstream filters clean the compressed air and remove dust, dirt, oil, and water droplets, before the compressed air reaches the dryer. Thus, an upstream filter is also used for extending the service life of the drying agent.

Downstream filters clean the compressed air from drying agent abrasions, before it is fed into the compressed air system.

The two chambers of the hollow section vessel contain an extremely porous drying agent by means of which humidity is removed from the compressed air and stored just as in a sponge. The stored humidity is then removed again from the drying agent and re-introduced into the ambient environment.

To this end, the two chambers alternate between different operating modes. Whilst in one vessel, compressed air is de-humidified (adsorption), in the other vessel the humid drying agent is prepared for another charge (regeneration). These two states, which run in parallel during compressed air preparation, are described below.

Adsorption

Via a compressor, humid compressed air is supplied to the upstream filter. From here, the compressed air flows upwards through the absorption chamber, which is pressurised. In so doing, the drying agent dehumidifies the air. The dry compressed air is supplied to the pipe network via the downstream filter.

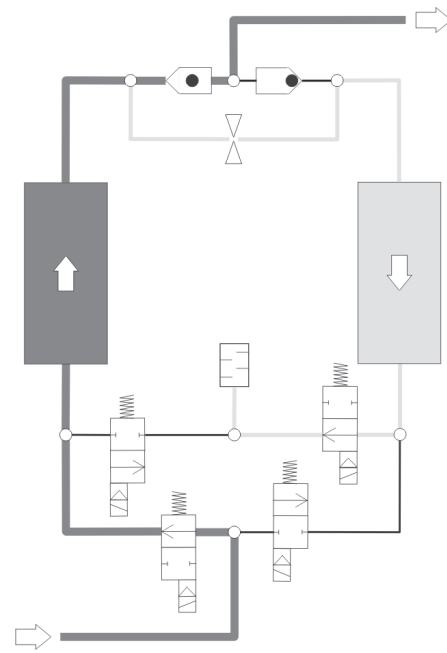

Here, adsorption is shown in the left vessel.

Regeneration (running in parallel to the adsorption)

At the same time the other chamber is prepared for a renewed take-up of humidity. This process is called regeneration.

The regeneration is subdivided into three phases: expansion, dehumidification, and pressure build-up. With the dewpoint-sensing control option, the regeneration phase is followed by a standby phase.

Expansion phase

During the expansion phase the pressure in the right chamber is released via the muffler down to ambient pressure within just a few seconds. The outflow of the compressed air becomes noticeable due to a sudden powerful flow noise at the muffler.

Dehumidification phase

Prior to being released into the pipe network, dried compressed air is bled by means of an orifice plate. This separate regeneration air flow is fed through the depressurised chamber. The humidity stored in the drying agent is taken up by the air flow and expelled into atmosphere via the muffler.

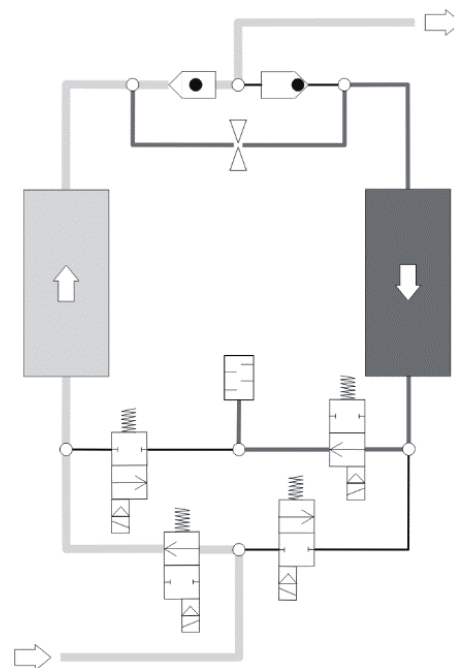

Here, regeneration is shown in the right vessel.

Pressure build-up phase

After dehumidification the pressure in the regenerated hollow section vessel is built up to operating pressure, so that the switchover from regeneration to adsorption can take place at operating pressure level.

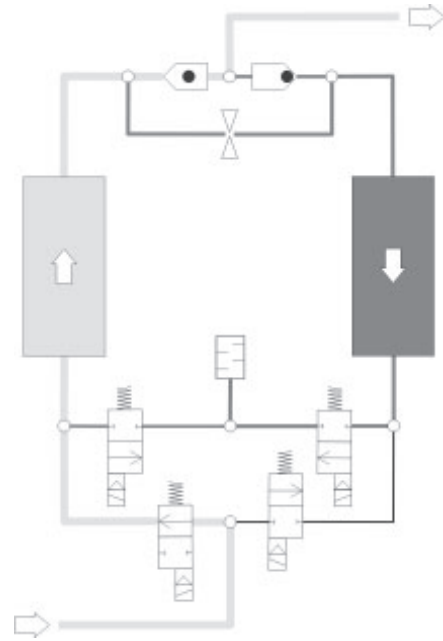

Pressure build-up

Standby phase (only with the dewpoint-sensing control option)

When in standby phase, the fully regenerated vessel is ready for absorption operation. The system is switched to this vessel, as soon as the measured dewpoint at the compressed air outlet has reached the set dewpoint value for switchover.

Switchover

When the drying agent in the adsorbing chamber has taken up a sufficient level of humidity, then the switchover between the vessels will be effected between the vessels. Following switchover, the above-described process is repeated, with the adsorption and regeneration now taking place in the respective different vessel.

Available options

The following options are available for the dryer:

- ◇ Start-up device
- ◇ Signalling contacts of the control system & compressor synchronisation
- ◇ Regeneration gas return
- ◇ Dewpoint-sensing control
- ◇ Fine filter muffler
- ◇ Nozzle kit

Start-up device

A start-up device basically consists of a pressure holding device, which is located at the rear of the dryer. The pressure holding device ensures that pressure can build up in the dryer and adsorption take place.

It is always required when an empty compressed air reservoir or an empty compressed air system must be filled downstream of the dryer (e.g. following weekend shutdowns and when the pressure in the compressed air system can frequently drop below the stated operating pressure).

Signalling contacts of the control system & compressor synchronisation

The control system is equipped with a digital input for the synchronised operation with a compressor. This feature allows for synchronised and thus efficient dryer operation with discontinuous compressor operation.

Compressor synchronisation helps reduce energy costs, as the dryer can be operated independently of the compressor.

The compressor synchronisation controller is a higher-level controller than the pressure dew point controller (see below). When both options are in place, the compressor synchronisation controller is treated as the prime controller.

The control system can also be equipped with an optional operation signalling contact with which the dryer operation can be monitored from an external device. Dryers with the optional dewpoint-sensing control are equipped with such a contact as standard. It is used for the transmission of operating signals and for the output of dewpoint alarms.

Regeneration gas return

When the compressor is switched off, the regeneration gas return ensures that regeneration is continued, as soon as a certain compressed air volume is reached behind the dryer. The regeneration process must be continued and ended so that the drying agent does not become unusable prematurely.

Dewpoint-sensing control

With a dewpoint-sensing control system, you can operate the dryer in fixed or variable cycles. In the fixed cycle, switchover is effected after a fixed time period (usually after 5 minutes). In the variable cycle, the switchover is effected in relation to the dew point reached and the charging of the drying agent. The adsorption time in the variable cycle amounts to 60 minutes maximum.

Fine filter muffler

A fine filter muffler is used to reduce the noise emission of the dryer to lower levels than the standard muffler can provide. If installed, the fine filter muffler replaces the original installed muffler.

Nozzle kit

In the case that the operating pressure deviates from the standard design pressure (7bare) it is possible that the amount of necessary regeneration air changes. This effect may have a negative impact on the cost-effectiveness of the dryer. To prevent this, it is possible to replace the built in regeneration air nozzle by a nozzle with a modified bore. This replacement optimizes the regeneration air consumption and therefore restores the energy efficiency of the dryer. To receive more information on this conversion, please contact the manufacturer.

Installation



Warning against hazardous electrical voltage

Different parts of the dryer carry electrical current. These parts may be connected, opened, and maintained by authorized specialist personnel only.

As soon as the dryer has been set up at its installation location, you can install the compressed air infeed and outlet lines make the electrical connections.

Preconditions for installation

For a correct installation the following preconditions must be met on the part of the owner.

- ◇ Connections and lines for the infeed and outfeed of compressed air must be provided.
- ◇ A compressed air inlet valve as well as a compressed air outlet valve must be installed by the owner, so that the dryer can be installed and maintained in a depressurised condition (see also the installation example on page 20).
- ◇ All pipes, couplings, and connections must have the correct diameter and match the operating pressure.



Hazard caused by exceeding the limit values!

A safety device must be provided in order to protect against the maximum permissible operating pressure from being exceeded.

The safety device must be installed so that the dryer is reliably protected from exceeding the maximum permitted operating pressure even when the temperature of the compressed gas increases.

The data required to meet these preconditions are contained in the technical documentation attached in the annex.



Warning!

If the above preconditions are not complied with, a safe operation of the dryer cannot be assured. Also, the functionality of the dryer may be detrimentally affected.

Connect piping

In order to ensure that the dryer operates optimally, the dryer must be assembled into the compressed air system free of all stresses.

- ▶ Ensure before connection that all infeed and outfeed compressed air lines and valves are clean and undamaged.
- ▶ Check the bolt connections and retighten if necessary, as they could have worked loose during transportation.
- ▶ Remove plugs on the pressure inlet and outlet.



All piping must be free from any stress and tension whatever! Pipes subject to stress may burst due to the load placed on them during operation. This may cause damage to property and personal injury.

- ▶ Use steel pipes to connect the dryer to the compressed air system. The following figure shows an installation example.

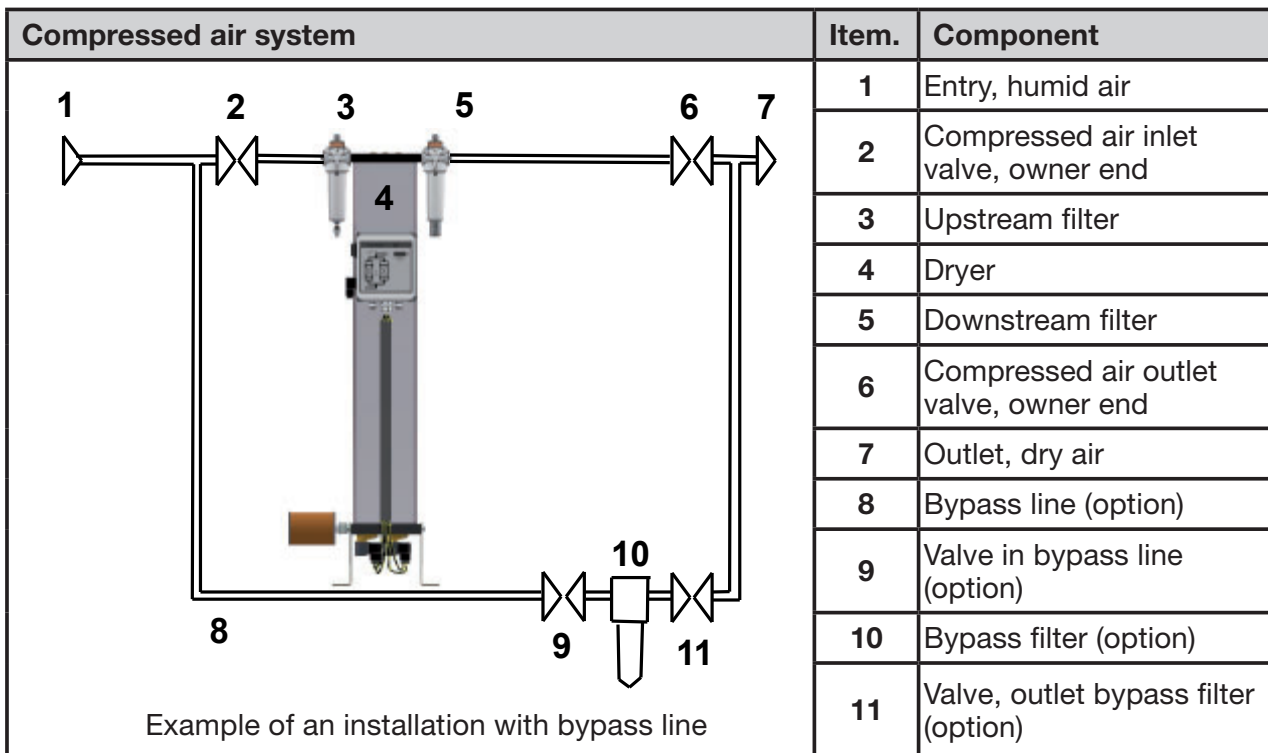

- ▶ The connection lines for the upstream filter (3) are to be installed at a slight incline in the direction of the upstream filter.
- ▶ One shutdown valve each (2, 6) is to be installed at the compressed air inlet and outlet ends of the dryer.
- ▶ If you fit a bypass line (8) with additional shutdown valve:
Fit the line such that, when carrying out maintenance work on the dryer, the line system can continue to be supplied with compressed air.

Installing the electrical connection



Warning against electrical voltage

Only qualified specialist personnel may carry out work on the electrical system!

Installing the supply cable

The components of the dryer have been connected to the control cabinet at the factory. You only need to connect the control cabinet to the electrical supply cable.

The switchbox is provided with a connector where electrical power must be connected.

► Ensure that the cross-section of the electrical supply cable corresponds to the power rating of the dryer and the electrical voltage provided by the customer.

► Make the electrical supply cable to the dryer voltage-free.

► Secure the electrical supply cable to the dryer against switch-on.

► Undo bolt (1) on the connector and withdraw connector with seal from the switchbox.

► Use a suitable tool to remove the terminal block from the connection box.

► Undo the PG union and pull the cable through the aperture (3). The exposed phase ends should not be longer than 35 mm max.

► Now make the cable connection as follows:

— .. Earth to terminal PE

— .. L1 to terminal 1

— .. N to terminal 2

Terminal 3 is not used.

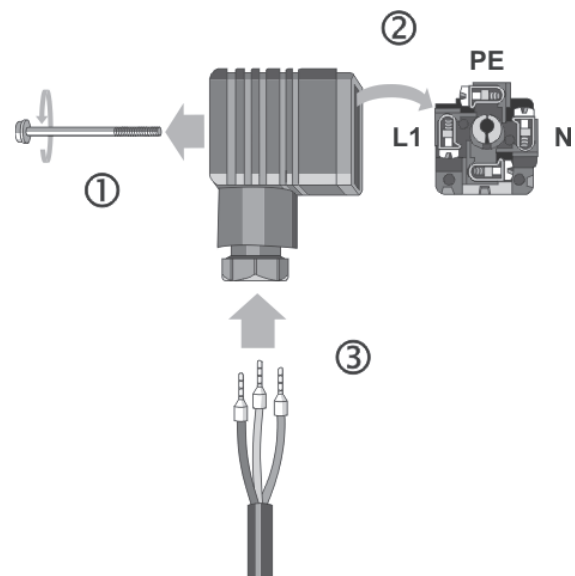

Connect electrical cable to device adapter

► Fit terminal block into the connector and use bolt to remount the connector with seal on the switchbox.

► In all phases the dryer must be protected against short circuits by means of fuses.

► In order to relief cable strain, re-tighten the PG union.

Connecting the external signalling lines

For compressor synchronisation

The controller is fitted as standard with a digital input which makes the dryer regeneration dependent on operation of the compressor (switch S1 on the controller's circuit board, see also figure below).

If switch S1 is in the ON position, operation of the compressor and dryer regeneration run synchronously: When the compressor is stopped, the dryer regeneration also stops. When the compressor is restarted, regeneration also restarts.

If switch S1 is in the OFF position, any regeneration process which has been started, is always continued until completed.

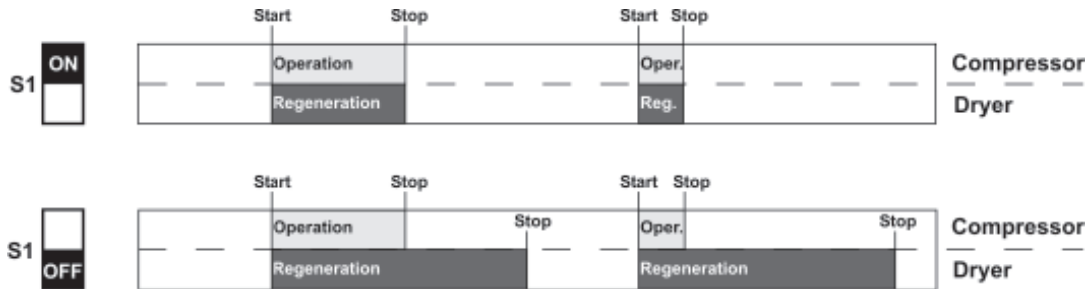

To install the external line, proceed as follows:

- ▶ Connect the signalling line to the potential-free busbar connection of the compressor to terminals 1 and 2 on the control board (see circuit diagram).

Hinweis:

The compressor synchronisation controller is a higher-level controller than the pressure dew point controller. When both options are in place, the compressor synchronisation controller is treated as the prime controller.

For operation monitoring system (optional)

Operators have the option to connect the dryer to a fault signalling system, connecting the respective line to a potential-free operation signalling contact. With this option, the following statuses and events can for example be transmitted to a remote control room:

- ◇ Dryer on (contact made)
- ◇ Power supply disconnected (no contact)
- ◇ Dewpoint alarm (only with dewpoint-sensing control option, no contact)

To install the external lines, proceed as follows:

- ▶ Connect the lines of the fault signalling system to relay K5 (see circuit diagram).

Check bolt connections

Before the initial start-up:

- ▶ Check all unions and bolt connections as well as the terminals in the control cabinet for secure seating; re-tighten if necessary.

Start-up

- ◇ Carry out all prescribed tests and checks.
- ◇ Before start-up, ensure that no tools or other foreign parts have been left lying in a part of the dryer where they might pose a hazard to the dryer being started up.

Requirements for initial start-up

For the first start-up the following preconditions must have been met:

- ◇ The pipe system is free from contaminations.
- ◇ All shutdown valves are closed.
- ◇ The dryer is correctly sited and installed.

Checks before start-up

Ensure that

- ◇ all pipe, cable and bolt connections on the dryer have been retightened,
- ◇ no pipes chafe against body edges,
- ◇ all mountings are perfectly secure,
- ◇ the needle valve of the oil indicator is closed,
- ◇ the electrical connections are in safe contact and in good condition,
- ◇ owner-end and pressurised parts such as safety valves or other devices are not blocked up by dirt or paint,
- ◇ all compressed air system parts which are pressurised (valves, hoses etc.) are free from wear symptoms and defects.

Setting times of the operating phases

In its standard version the dryer is delivered with a time-dependent control system. The phase sequence occurs in a fixed cycle.

With the optional dewpoint-sensing control, the dryer can also be operated at variable cycles (depending on the dewpoint).

The following table provides information on the duration of the individual phases

Phase duration	Fixed cycle	Variable cycle
Adsorption	5 min	60 min, max
Regeneration, total	5 min	5 min
- of which: expansion time	~ 0,2 min	~ 0,2 min
- of which: dehumidification time	~ 4 min	~ 4 min
- of which: pressure build-up	~ 1 min	~ 1 min
Standby	--	~ 55 min, max.

Overview of operating and control elements

ON/OFF switch

The ON/OFF switch (2) is located to the side of the switchbox and above the mains plug (1, see figure):

- ◇ If it is set to 0, the power supply is disconnected and the dryer is switched off. The main valves (V1, V2) are open, while the expansion valves (V3, V4) are closed. This means that the air can circulate in the main processing direction, even if the dryer is switched off.
- ◇ If the switch is set to **I**, the dryer is switched on and begins to operate in fixed cycle mode (i.e. time-controlled).
- ◇ If the switch is set to position **II**, the dryer is switched on and begins to operate
 - with compressor synchronisation
 - in variable cycle mode (i.e. dew-point-controlled).

Position **II** is only relevant for operation with the optional compressor synchronisation and/or dewpoint-sensing control

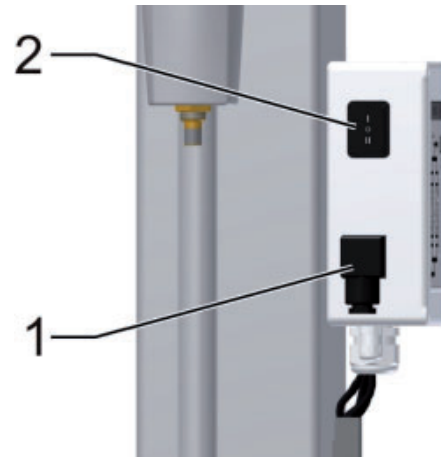

Switchbox with ON/OFF switch

Display panel

The display panel at the switchbox is equipped with LEDs (light emitting diodes) and a digital display, indicating the operating status of the dryer:

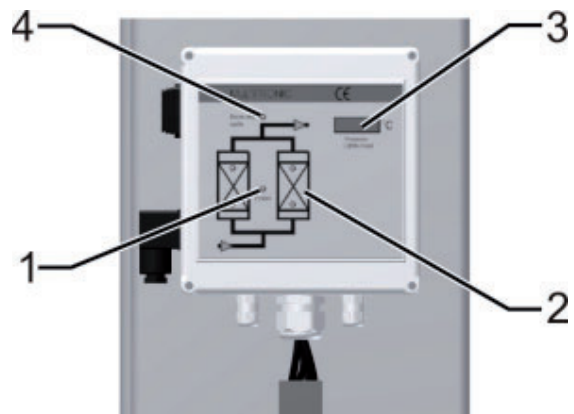

Display panel at the switchbox

LED Power (1)

LED is on when dryer is switched on.

Flow diagram (2)

The current operating phases of the dryer are indicated by means of 4 LEDs:

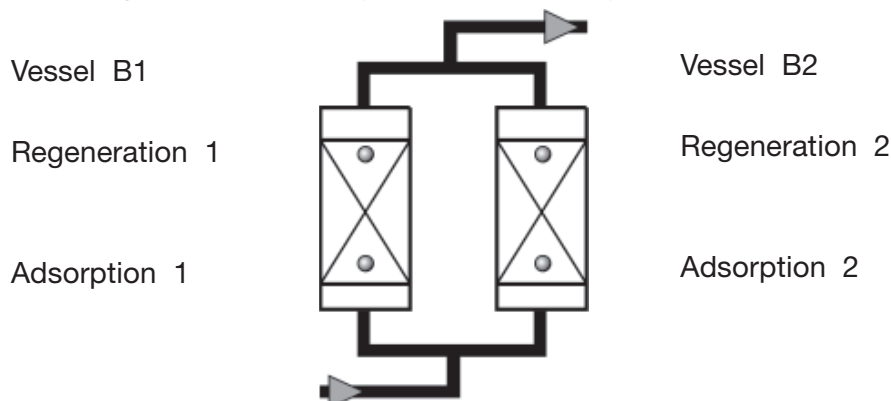

Depending on the operating phase, the following LEDs might be on simultaneously:
Adsorption B1 and regeneration B2 or regeneration B1 and adsorption B2.

Digital display (3)

The digital display shows the individual programme steps and the respective remaining time. For details regarding the sequence of the individual processing steps and their duration, please refer to the logic control diagram, page 49.

Display		Explanation
2	215	Default display: The figure to the left indicates the current processing step; the figure to the right shows the remaining time in seconds. In this example, step 2 is being completed, whereby there are 215 seconds remaining.
SEr		After 8000 operating hours, "SEr." (service) is displayed for periods of 1 minute, alternating with the default display. Notify the service personnel of the manufacturer, as a routine service is now due.
-25		With the dewpoint-sensing control option, the display shows the currently measured dewpoint instead of the default data. The range of display is 100 °C (-148 °F) to +20 °C (68 °F). If the measured dewpoint exceeds the preset alarm limit (5 °C (41 °F) above the switchover value), the displayed dewpoint value is flashing.

With the optional dewpoint-sensing control, the following error messages might be displayed:

Display	Cause
+20	◇ Upper measuring range limit exceeded
999	◇ Dewpoint sensor defective.
sens	◇ Dewpoint sensor not powered
o	◇ Cable defective or disconnected
-999	◇ Sensor defective

LED Economy cycle (4)

This LED is only relevant in units that are equipped with the optional dewpoint-sensing control. The diode lights up when the dryer is switched on and in the standby phase and no regeneration air is required.

Start up dryer



Warning against sudden air ejection!

During expansion the pressure is released suddenly through the muffler:

- ◇ A loud cracking noise occurs which can injure your hearing.
- ◇ Particles carried in the air flow act like bullets and can injure your eyes or skin.

Always wear eye and ear protection, therefore, when you are in the vicinity of the dryer!



Hazard due to a sudden release of pressure!

Never remove any parts of the dryer, or manipulate the same in any way, for as long as the plant is still pressurised! A sudden escape of pressure may cause serious injuries.

Before carrying out any work on the dryer, first depressurise the plant.

- ◇ Carry out all prescribed tests and checks.
- ◇ The factory settings on the control board in the switchbox must not be changed on any account without prior approval by the manufacturer.
- ◇ Before start-up, ensure that no tools or other foreign parts have been left lying in a part of the dryer where they might pose a hazard to the dryer being started up.

Open compressed air supply and switch on dryer

For start-up, please proceed in the sequence shown here.

- ▶ Ensure that the compressed air inlet and outlet valves installed by the owner are closed (see installation example on page 20).
- ▶ Ensure that the compressed air system upstream of the dryer is pressurised. If necessary, pressurise (switch on compressor).



Slowly open compressed air inlet valve!

Avoid sudden pressure build-up in any circumstance! If pressure builds up too fast, this may cause damage to the dryer. Therefore, the compressed air inlet valve must always be opened quite slowly!

- ▶ Slowly open the compressed air inlet valve, installed by the owner, upstream of the dryer.
- ▶ Switch on dryer: to this end, set the ON/OFF switch to I

If the dryer is taken into operation for the first time, or after a change of drying agent, the following intermediate step is meaningful. In the case of a restart situation, the following intermediate step can be skipped.

Operating the dryer for the first time (or after a change of drying agent) separately

Depending on the transportation and storage conditions, the drying agent in the chambers can already be loaded with humidity from the environment. At each first start-up it makes sense therefore to operate the dryer from some time separately from the compressed air system. This causes the drying agent in each chamber to be regenerated repeatedly and thus to be prepared optimally for the take-up of humidity.

Note:

Depending on the pressure dew point to be achieved, we recommend to operate the dryer at first start-up:

- ◇ for pressure dew point of -25 to -40 °C: without compressed air consumption for at least 4 hours;
- ◇ for pressure dew point of -70 °C: without compressed air consumption for 1 day and then at a reduced nominal flow of 50% during the next 6 to 7 days without regard for the dew point.

If you wish to take the dryer into operation in accordance with our recommendation, proceed as follows:

- ▶ Ensure that the compressed air outlet valve installed by the owner is closed.
- ▶ Keep the compressed air outlet valve closed for the time period recommended above.

Then the dryer can be taken into service in the compressed air system as described in the following section:

Operate dryer immediately in the compressed air system

- ▶ Ensure that the compressed air system downstream of the dryer is pressurised or that a start-up device (option, see page 17) was installed into the compressed air system directly downstream of the dryer.

The importance of this increases with the size of the compressed air system downstream of the dryer. Smaller compressed air systems can be pressurised also by means of compressed air fed through the dryer.

**Slowly open compressed air outlet valve!**

Avoid a sudden drop in pressure in any circumstance! If pressure drops too fast, this may cause damage to the dryer. Therefore, the compressed air outlet valve must always be opened quite slowly!

- ▶ Slowly open the compressed air outlet valve installed by the owner. The pressure should not drop below the operating pressure (if poss.). If necessary, keep the compressed air outlet valve in a slightly open position until the compressed air system downstream of the dryer has filled up completely; only then should the valve be opened fully.

The dryer has then be taken into operation within the compressed air system.

In the event of a fault

In the event of an emergency or if a safety-relevant disruption occurs (e.g. escaping compressed air, defective component), immediately close the compressed air supply line and set the ON/OFF switch of the dryer to 0 in order to disconnect it from the power supply. Afterwards depressurise the dryer (see also chapter , page 31).

Then proceed as follows:

Remedy fault:

- ▶ Look up possible cause of the fault, and how to remedy the same, in the table on page 43.
- ▶ Remedy fault.
- ▶ Repeat the start-up procedure.

Changing cycle mode (optional)

When can I change cycle mode?

If the dryer has been successfully commissioned and is equipped with one of the following options:

- ◇ compressor synchronisation or
 - ◇ dewpoint-sensing control
- it can be set to economy cycle mode.

When should I change cycle mode?

Cycle changes should be made during the pressure build-up phase and prior to switchover; during this phase, the pressure in both vessels is just below operating pressure so that a fast pressure build-up is prevented when the vessels are switched.

During this period, only the adsorption LED is on in the diagram, and the digital display shows step 4 or step 9 for the duration of 1 minute (see logic control diagram; not displayed with dewpoint sensing).

Which cycle modes can I choose?

If the dryer is connected to a compressor synchronisation system and is equipped with the dewpoint-sensing control option, these two optional devices can only be started together. The compressor synchronisation has thereby precedence over the dewpoint-sensing control.

With compressor synchronisation

If compressor synchronisation is enabled, the dryer can only be operated in conjunction with the compressor. As soon as the compressor is switched off, the dryer is automatically set to standby mode.

In standby mode, the control system remains on, and the dryer is ready for the next switchover, which is made as soon as the compressor is switched on.

Note:

The compressor synchronisation controller is a higher-level controller than the pressure dew point controller. When both options are in place, the compressor synchronisation controller is treated as the prime controller.

With dewpoint-sensing control

Dryers equipped with dewpoint-sensing control operated in variable cycle mode, based on the measured dewpoint of the dried air at the compressed air outlet. As soon as a certain dewpoint is reached, as the drying agent in the absorbing chamber is saturated, the chambers are switched.

The dewpoint at which a switchover is made is preset at the factory.

How do I change cycle mode?

- ▶ Wait until the dryer has reached the pressure build-up phase (phase prior to switchover). One LED for Adsorption B1/B2 is on in the flow diagram.
- ▶ Set the ON/OFF switch to position **II**.
The programme continues the cycle.

Monitoring dryer operation

The dryer operates fully automatically. However, you should carry out the regular checks described in the Chapter Maintenance and repair of the dryer.



Warning against sudden air ejection!

During expansion the pressure is released suddenly through the muffler:

- ◇ A loud cracking noise occurs which can injure your hearing.
- ◇ Particles carried in the air flow act like bullets and can injure your eyes or skin.

Always wear eye and ear protection, therefore, when you are in the vicinity of the dryer!

- ◇ The more powerful the dryer is, the more noise may be generated during operation. Therefore, the operator must provide suitable protective equipment (e. g. ear protection).
- ◇ Only operate the dryer within the permissible limits (see type plate). By operating the dryer in conditions that go beyond the defined values, the dryer is subjected to loads for which it has not been designed. This may cause functional defects.
- ◇ Check the dryer regularly for externally visible damage and defects. Any changes, even in its operating behaviour, must be reported immediately to the competent office or person.
- ◇ In the event of an emergency or if a safety-relevant disruption occurs (e.g. escaping compressed air, defective component), immediately close the compressed air supply line and set the ON/OFF switch of the dryer to 0 in order to disconnect it from the power supply. Afterwards depressurise the dryer (see also chapter , page 31). The unit may only be restarted after all defects have been eliminated.

With dewpoint-sensing control (optional)

Display of dewpoint

If the dryer is equipped with a dewpoint-sensing control system, the digital display at the front of the switchbox shows the currently measured dewpoint. The range of display is $-100\text{ }^{\circ}\text{C}$ ($-148\text{ }^{\circ}\text{F}$) to $+20\text{ }^{\circ}\text{C}$ ($68\text{ }^{\circ}\text{F}$).

If the set dewpoint is exceeded, the system automatically completes a switchover between the chambers. The dewpoint at which a switchover is made is preset at the factory.

► After commissioning or extensive maintenance work, check the dewpoint display at the dryer.

Under certain circumstances, the desired dewpoint is only reached after prolonged operation.

Error messages

If the measured dewpoint exceeds the preset alarm limit ($5\text{ }^{\circ}\text{C}$ ($41\text{ }^{\circ}\text{F}$) above the switchover value), the displayed dewpoint value is flashing. In addition, an error message can be issued through the potential-free busbar.

Error codes and their causes:

Display	Cause
+20	◇ Upper measuring range limit exceeded
999	◇ Dewpoint sensor defective
sens	◇ Dewpoint sensor not powered
o	◇ Cable defective
-999	◇ Sensor defective

For instructions on how to eliminate faults, see chapter Identify and eliminate faults

Shutdown and restart dryer

In the following cases, the dryer must be fully shut down and depressurised:

- ◇ In the event of an emergency or malfunction
- ◇ For maintenance work
- ◇ For dismantling



Caution!

Risk of damage to the dryer, if it is switched off during the expansion or drying phase.

During these phases, the pressure in the regenerating chamber is released to ambient pressure: If the main valve is opened, as the dryer is switched off, there is a sudden pressure build-up in the chamber. This might result in

- ◇ damage to the drying agent, and
- ◇ excessive abrasion, with negative impact on the regeneration capacity.

Before switching off the dryer, wait until it has reached the pressure build-up phase or is in standby mode (before switchover).

Note:

If the unit is equipped with a compressor synchronisation system, first switch off the compressor and then wait until the dryer has reached the standby phase before switching it off with the ON/OFF switch.

This ensures that the regeneration cycle is completed, and that the pressure in both chambers is at the same level.

As soon as the dryer is switched on again, the programme continues the cycle from the point at which it has been stopped.

Emergency shutdown

To emergency shut-down the dryer heed to the following instructions:

- ▶ Close shut off valves upstream and downstream of the dryer (if applicable)
- ▶ Disconnect the electrical power supply (i.e. by switching the On/Off switch to **0**).
- ◇ The dryer is now off-line.
- ▶ If applicable, depressurise the dryer now.

Before re-commissioning of the dryer ensure that the emergency situation has been solved and that the dryer is not damaged.

Never commission a damaged dryer!

Depressurising and shutting down the dryer

Close compressed air feed line

- ▶ Close the compressed air inlet valve (provided by the operator).

Disconnect voltage supply

- ▶ Switch off the dryer by setting the ON/OFF switch to position **0**.

Disconnect dryer from compressed air system

- ▶ Close the compressed air outlet valve installed by the owner.
- ▶ If available, open bypass line.

Depressurise dryer

- ▶ Depressurise dryer, e.g. by opening the manual drain at the downstream filter.

If work is to be carried out on the electrical system

- ▶ Depressurise and shut down the dryer, following the instructions in the above chapter.



Risk of injury due to voltage-carrying parts!

The electrical supply cable and external power lines are live even after the dryer is switched off and, in the event of body contact, may cause serious injury! Before carrying out any work on the electrical system, the electrical supply cable and all external power lines must be made voltage-free!

- ▶ Make the electrical supply cable to the dryer voltage-free.
- ▶ Secure the electrical supply cable to the dryer against switch-on.

Restart

Depending on the fittings installed by the operator and the actual pressure conditions, the unit might have to be restarted at operating pressure. The following general rules apply:

- ◊ When switched off, the dryer is open in main flow direction. With the optional start-up device, the set minimum pressure must however be reached prior to restart.
- ◊ A return flow is only possible in connection with the optional regeneration gas return (and provided that the pressure outlet valve is open).
- ◊ If the dryer is equipped with a dewpoint-sensing control system, it is depressurised gradually, according to the read measuring current.

If compressed air system and dryer have remained at operating pressure

- ▶ Ensure that the compressed air inlet valve (provided by the operator) is open.
- ▶ Set ON/OFF switch to **I**. The programme continues the cycle from the point at which it was interrupted.



Slowly open compressed air outlet valve!

Avoid a sudden drop in pressure in any circumstance! If pressure drops too fast, this may cause damage to the dryer. Therefore, the compressed air outlet valve must always be opened quite slowly!

- ▶ Slowly open the compressed air outlet valve installed by the owner. The pressure should not drop below the operating pressure (if poss.). If necessary, keep the compressed air outlet valve in a slightly open position until the compressed air system downstream of the dryer has filled up completely; only then should the valve be opened fully.
- ▶ If available, block off bypass line.

The dryer is now in operation again and operates fully automatically.

If compressed air system and dryer have not remained at operating pressure

- ▶ If disconnected, reconnect the voltage supply of the dryer.
- ▶ Ensure that the manual drain on the downstream filter is closed.
- ▶ Pressurise and switch on the dryer as described in the section Open compressed air supply and switch on dryer on page 27.

The dryer is now in operation again and operates fully automatically.

Maintenance and repair of the dryer

In order to allow maintenance work on the dryer to be carried out efficiently and without danger for maintenance personnel, you should comply with the following instructions.

Notes on maintenance

**Danger!**

There is a very considerable risk of personal injury, when carrying out work on the activated and pressurised dryer.

**Danger!**

Before commencing any maintenance tasks always shut down the dryer as described on page 31 !

**Warning!**

Maintenance tasks may be carried out only by authorized and qualified specialist personnel, and only with the plant in a switched off and depressurised condition.

Note:

In order to ensure perfect maintenance and reliable operation we recommend that you conclude a maintenance contract.

When exchange or replacement parts are ordered, always state the dryer type and the build no. of the dryer. These data are found on the type plate.

- ◇ Carry out all maintenance work only when the plant has been shut down and depressurised!
- ◇ Bolt connections must be undone with care! Note ram pressure values! Otherwise emerging media may cause personal injury.
- ◇ Do not modify the factory settings of the control system in any way without prior consultation with the manufacturer.
- ◇ Never carry out any manipulations on a hollow profile vessel or modify the same in any way!
- ◇ Following maintenance work, always check all flange and bolt connections for leakage and secure seating.
- ◇ Never use pipes and fittings as steps or holding points! The components might fracture, or the distortions which occur may cause internal damage on the dryer. There is a risk of injury by slipping off the components, components breaking off, and expanding compressed air!
- ◇ Never leave tools, loose parts or cloths at or on the dryer.
- ◇ Only use replacement parts that are suitable for the relevant function and meet the technical requirements stipulated by the manufacturer. This is always the case, if you use original replacement parts only.

Regular maintenance intervals

Note:

If a chamber has been depressurised, e.g. after completion of the ex-pansion phase, and the pressure remains above 0 bar, the chamber is pressurised by what is known as ram pressure. This might be due to

- ◇ blockage at the muffler(s)
- ◇ contamination of the perforated plates
- ◇ spent drying agent

To prevent such malfunctions, regularly service the dryer as described below.

The table provides an overview of the maintenance work to be carried out. The individual tasks are described in the following pages.

Component	Maintenance task to be carried out	Maintenance interval				
		daily	12 months	24 months	48 months	See page
Complete dryer	Carry out visual checks and function checks.	•				35
Muffler	K-MT 1-2 : Clean muffler, replace if necessary.		•		•	36
	K-MT 3-8 : Mufflers must be replaced annually and after each desiccant change.		•		•	36
Fine filter muffler (option)	Replace silencer element annually and after each desiccant change.		•			37
Sensor of optional dewpoint-sensing control system	Replace.		•			37
Solenoid valves	Replace membrane.			•		38
Solenoid and check valves	Solenoid valves: Replace membranes and coils. Check valves: Replace balls and springs.				•	38
Demisters, perforated plates, drying agent	Replace				•	39
Upstream and downstream filter	Please see the enclosed operating instructions for the attached filters. Maintenance work has to be carried out as specified in this document.					

Instructions for use of the dongle

If the message **SEr**, is displayed on the display of the Multitronic controller, the dryer is due for servicing. The message appears, flashing every 60 seconds, once the preset number of operating hours (e. g. 8000 oh) has been reached. After maintenance has been carried out, you can use the dongle to reset the counter to 0 and delete the message from the display. A dongle is enclosed with every service kit. Each dongle can only be used once.

- ▶ Switch off the controller. Caution! The electric line is still live. Do not touch live parts!
- ▶ Open the lid to the Multitronic controller. The circuit board is housed underneath it.
- ▶ Slot the dongle into the dongle interface X9 PC.
- ▶ Press and hold the reset key S3.
- ▶ Switch on the controller. The following appears in the display:

for a short time	0.SET
then flashing	OFF

The service counter is then reset to 0.

If the following appears in the display

for a short time	FAIL
then flashing	OFF

this means that the dongle has already been used once and cannot be used again.

- ▶ Switch off the controller again and remove the dongle.
- ▶ Dispose of the unusable dongle and use a new one.

Daily maintenance tasks

Carry out visual and function check on the complete dryer

- ▶ Check dryer for external damage or unusual noise generation.
- ▶ Duly eliminate any defects found.

If message **SEr**. is displayed, a routine service must be completed:

- ▶ Contact the service department of the manufacturer.

Clean dryer

- ▶ Remove any loose dust by means of a dry cloth, and, if required, also by means of a moist and well wrung cloth.
- ▶ Clean the surfaces with a moist well wrung cloth.

Maintenance work to be completed every 12 months

Check mufflers

The dryer is either equipped with a standard muffler or a fine filter muffler. If the respective muffler becomes blocked, a dam pressure is generated which in extreme cases may cause the muffler to burst.



Hazard caused by blocked muffler!

Blocked mufflers can cause a dangerous overpressure to build up which may cause the mufflers to burst. Flying fragments may cause personal injury and damage to property.

Therefore, mufflers must be checked at least once a year and cleaned (K-MT 1-2) or renewed (K-MT 3-8) if they are contaminated.



Warning against sudden air ejection!

During expansion the pressure is released suddenly through the muffler:

- ◇ A loud cracking noise occurs which can injure your hearing.
- ◇ Particles carried in the air flow act like bullets and can injure your eyes or skin.

Always wear eye and ear protection, therefore, when you are in the vicinity of the dryer!

The correct procedures for all muffler versions are described below.

Clean or renew standard mufflers

- ▶ Depressurise the dryer and shut it down (see page 31).
- ▶ Unscrew muffler as shown in the opposite figures:
 - ..K-MT 1-2 = Pos. A,
 - ..K-MT 3-8 = Pos. B
- ▶ K-MT 1-2
 - ..Blow out with compressed air for cleaning
 - ..or renew muffler, if necessary.

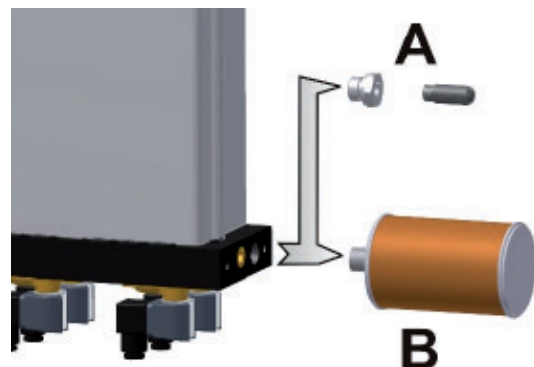

Undo muffler

- ▶ K-MT 3-8

Mufflers must be replaced annually and after each desiccant change.

- ▶ Screw sound absorber tight again.
- ▶ Restart dryer (see page 32).

Replace the element in the fine filter muffler

- ▶ Depressurise the dryer and shut it down (see page 31).
- ▶ Undo knurled screw on the lid cap and remove cap.
- ▶ Unscrew old filter element. Arrows on the element bottom mark the direction of rotation.
- ▶ Insert new filter element and screw on tightly.
- ▶ Re-engage lid cap at the top section of the housing and fix in position by means of the knurled screw.
- ▶ Restart dryer (see page 32).

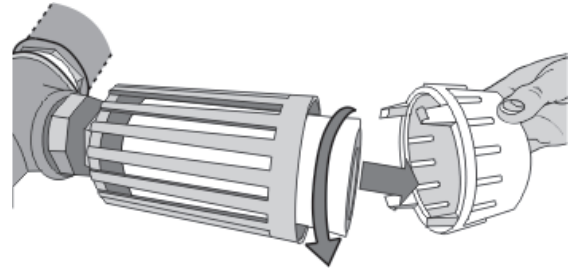

Renew muffler element

Renew dewpoint sensor

To ensure precision dew point measurement, it is recommended to replace the dew point sensor every year. This period depends however on the actual application and might thus be extended accordingly.

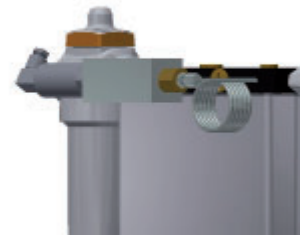

Dewpoint sensor (1)

Warning!

The dew point sensor is a sensitive measuring device. It can be damaged if subjected to forceful vibrations or shocks. Therefore, please handle the dew point sensor with great care at all times.

In order to limit the impact on the dryer operation to a minimum, we recommend that you contact the manufacturer well in advance and order a new dewpoint sensor. After receipt of the new pressure dewpoint sensor, replace the sensor as follows:

- ▶ Hold the box of the dewpoint sensor ready.
- ▶ Release pressure from dryer and shut down the unit (see page 31)

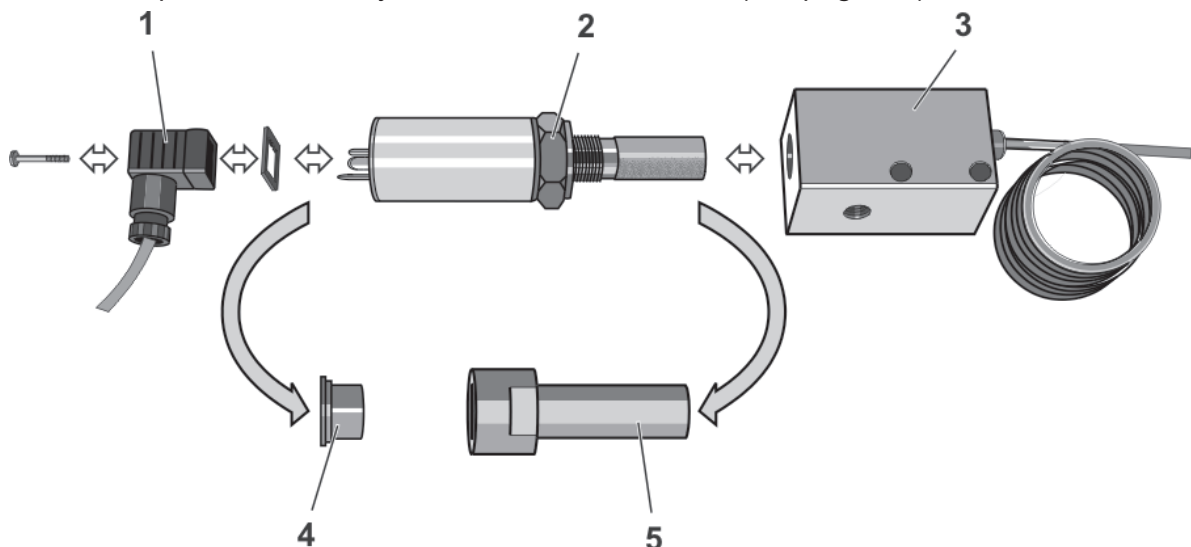

- ▶ Loosen the screw at the adapter (1) and disconnect signal cable with the adapter and

seal.

- ▶ Remove dewpoint sensor from the sensor cell (3) by turning the nut (2).
- ▶ Take the new dewpoint sensor (2) from the box, remove the protective caps (4, 5) and screw it into the sensor chamber (3).
- ▶ Place seal onto sealing face; connect adapter (1) and secure it by tightening the screw.
- ▶ If no other maintenance work is to be carried out: Restart the dryer (see page 32).
- ▶ Place the protective caps (4, 5) onto the old dew point sensor and dispose of it in accordance with the applicable regulations.

Maintenance work to be completed every 24 months

Replace the membranes of solenoid valves

You should replace the membranes of solenoid valves every two years. Proceed as described in section Replace solenoid valves . You must, however, replace the membranes only (contained in the Service Kit for 24 months).

Maintenance work to be completed every 48 months

Replace check valves

Check valves are wear parts and must thus be replaced every 48 months, even if no damage is visible.

- ▶ Release pressure from dryer and shut down the unit (see page 31).
- ▶ Remove the securing screws at the rear of the check valve plate.
- ▶ Insert new balls and new springs and ensure that they are not jammed.
- ▶ Replace the seals at the securing screws and tighten the screws.

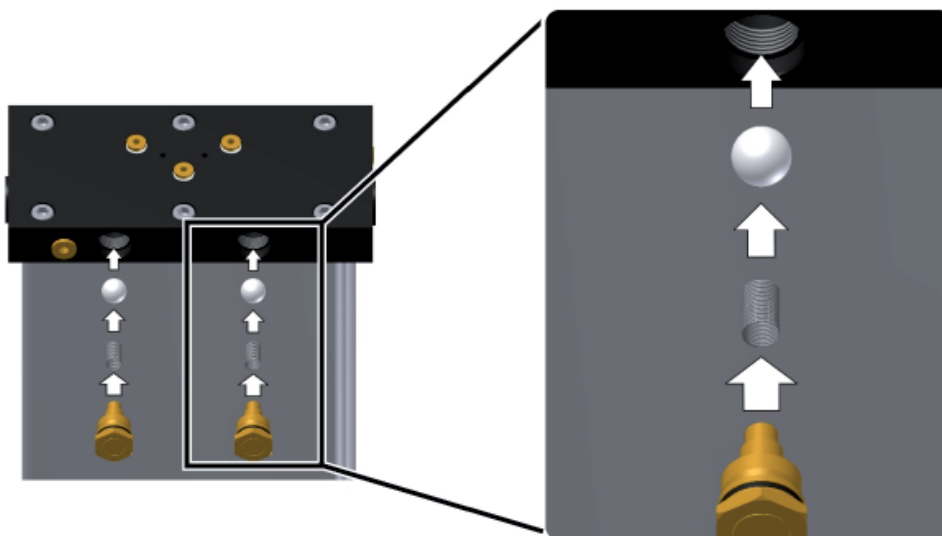

- ▶ With regeneration gas return (optional):
Also replace the two additional check valves, following the above instructions.
- ▶ If no other maintenance work is to be carried out: Restart the dryer (see page 32).

Replace solenoid valves

Solenoid valves are wear parts and must thus be replaced every 48 months, even if no damage is visible.

► Release pressure from dryer and shut down the unit (see page 31).

Preparation for the replacement of all four solenoid valves:

- Check the specifications of the valves:
 - The rated voltage of the solenoids (1) must correspond to that indicated on the type plate of the dryer.
 - Solenoid valves Y1/Y2 at the dryer rear must be open when not energised (valve piston without notch, 2).
 - Solenoid valves Y3/Y4 at the dryer front must be closed when not energised (valve piston with notch, 2).
- Position the new solenoid valves at the points at which they are to be mounted in order to prevent any confusion at a later stage.

For each solenoid valve, proceed as follows:

- Remove solenoid valve from the holder (3). Remove the valve together with the solenoid and the diaphragm (4).
- Insert new diaphragm with guide (4) and secure it to the holder (3).
- Position new solenoid (1) onto the armature and secure it to the spring bracket (5).

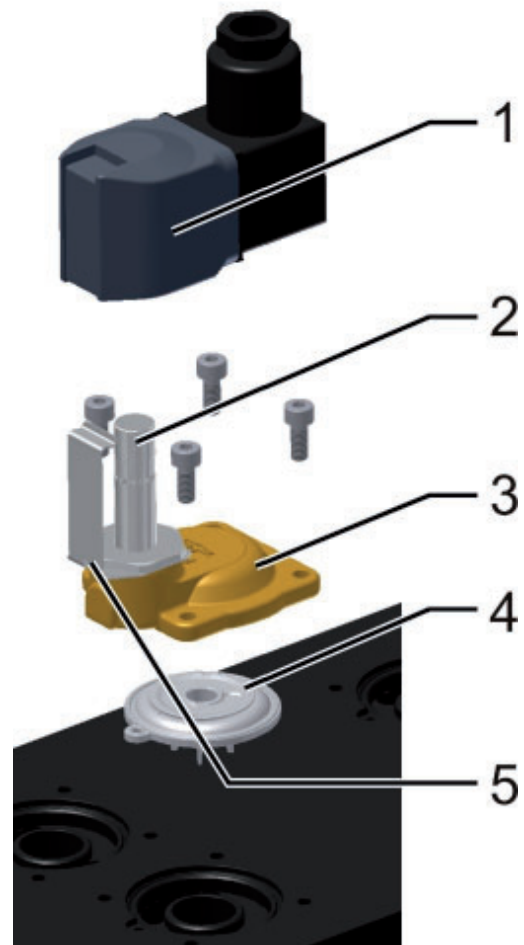

Solenoid valve

- If no other maintenance work is to be carried out: Restart the dryer (see page 32).

Replace perforated plates, demisters and drying agent

To complete the following maintenance tasks, you must dismantle the plates and the vessels. We therefore recommend that you carry out these tasks together.

Replace upper perforated plates

Perforated plates are fitted under the check valve plate and over the solenoid valve plate; these retain the drying agent. If these perforated plates become blocked, a dam pressure is generated which can cause compressed air fluctuations in the compressed air system. In order to remove the upper perforated plates, the check valve plate must be removed.



Risk of falls!

The dryer must not be misused as a climbing aid! The components have not been designed for such loads and could fracture.

Only use approved climbing aids when disassembling the check valve plate.

- ▶ Depressurise the dryer and shut it down (see page 31).
 - ▶ Loosen the screws at the check valve plate and lift off the plate.
 - ▶ Removing and replacing, perforated plate and pressure springs.
- Before reassembling the check valve plate, you should replace the drying agent.

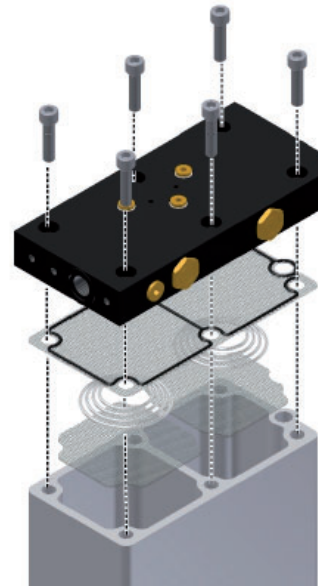

Removing the check valve plate

Replace drying agent

The service life of the drying agent is usually approx. 3 to 5 years. However, in favourable installation conditions, the change of drying agent may be carried out at a substantially later date (for notes on the installation site, see also page 10). The change interval is determined by the degree of contamination of the compressed air (which can be minimised by regularly replacing upstream filter elements). Oil, dust, and dirt particles cover the drying agent surface and reduce its effective surface, in part quite irreversibly. If in doubt, have a sample of your drying agent assessed by specialists.

Comply with the following safety notes when changing the drying agent:



Wear eye protection and dust mask due to increased dust generation!
When emptying the drying agent, increased dust generation may occur.



In order to avoid any eye irritations, wear protective goggles!
In order to avoid any dust inhalation, wear dust mask!



Risk of skidding!

If drying agent has been spilt on the floor, there is a risk of skidding caused by the drying agent beads. Therefore, spilt drying agent must always be taken up immediately.

Remove used drying agent

- ▶ Use an industrial vacuum cleaner to Hoover up carefully the drying agent out of the chambers.

Warning!



If the dryer is not used within specifications, the drying agent can be contaminated with pollutants. Always take this into account for the environmentally safe disposal of the drying agent. The waste code numbers of the drying agent can be obtained from the manufacturer.

- ▶ Dispose of the used drying agent in accordance with all applicable regulations.

Replacing the lower perforated plate

- ▶ Loosen the screws on the solenoid valve plate.
- ▶ Remove and replace perforated plate and demisters.

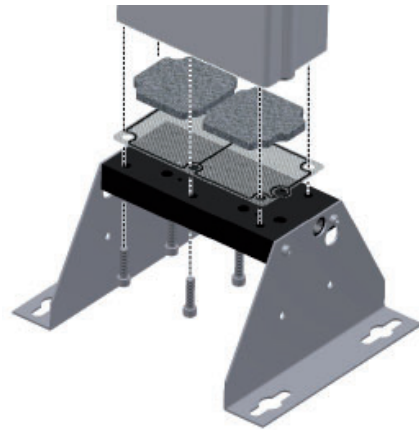

Loosen the solenoid valve plate

Reaffix the solenoid valve plate:

- ▶ Use a dynamometric key to tighten the screws, and take care to observe the following torques:
 - 25 Nm in the case of K-MT 1-4
 - 50 Nm in the case of K-MT 6-8
 - ▶ Tighten the screws crosswise in accordance with the sequence shown on the right.
 - ▶ Repeat the process once.
- Next the new drying agent should fill up.

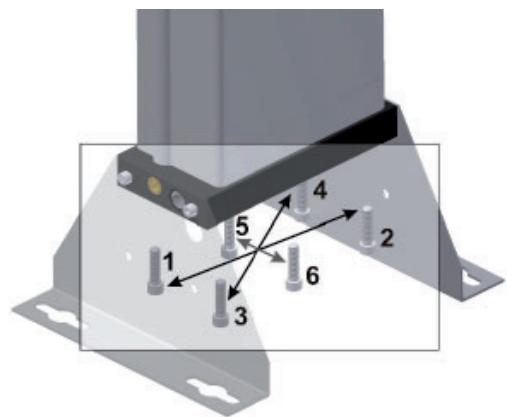

Correctly affixing the solenoid valve plate

Fill with new drying agent and remount check valve plate



Risk of falls!

The dryer must not be misused as a climbing aid. The components have not been designed for such loads and could fracture.

Only use approved climbing aids when filling the chambers.

- ▶ Slowly fill up with new drying agent in the chamber. If necessary, use a funnel. Take special note of the next step.
- ▶ Ensure that the drying agent is filled into the chambers with a high bulk density.

Note:

To achieve an optimum bulk density, we recommend using a „snowstorm“ filling pipe available from the manufacturer.

► Subsequently, position the perforated plate onto the check valve plate, align them properly and secure them.

Reaffix the check valve plate:

► Use a dynamometric key to tighten the screws, and take care to observe the following torques:

- 25 Nm in the case of K-MT 1-4
- 50 Nm in the case of K-MT 6-8

► Tighten the screws crosswise in accordance with the sequence shown on the right.

► Repeat the process once.

► Restart the dryer (see page 32). Check that the connection is leak tight.

► Operate the dryer for two cycles, then shut it down again.

Replace sound absorber as described on page 36

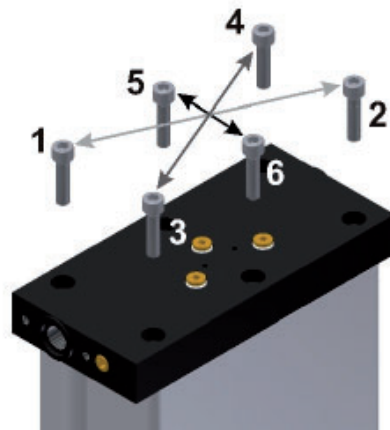

Correctly affixing the check valve plate

Identify and eliminate faults

The following table provides information on what designatory abbreviations are to be used for the various components. These designations are also found in the technical documentation.

Used abbreviation	Component
PDI	Differential pressure gauge (only K-MT 6–8)
V1–V2 (Y2–Y1)	Main valves (solenoid valves)
V3–V4 (Y3–Y4)	Expansion valves (solenoid valves)
RV1–RV2	Check valves
RV3–RV4	Check valves of regeneration gas return line (optional)

Summary of faults

There are different fault types. In the case of most electrically caused faults (e.g. short circuit, defective fuse, etc.) the expansion valve closes and the regeneration is interrupted. In the case of some process faults, the dryer will continue to operate for some time. Other faults on the dryer become noticeable e.g. due to unusual noises and ran pressures.

The following table shows who is allowed to remedy a fault: the owner's specialist personnel or the manufacturer's service engineer.

Table of possible faults

Fault	Possible cause	Remedy	Specialised personnel	Service technician
No pressure build-up	The compressed pressure system upstream from the dryer is not pressurised.	Check whether the compressed pressure system upstream from the dryer is pressurised. Eliminate any faults in the compressed air system.	•	
Excessive compressed air consumption	Leakage	Check condensate trap at the upstream filter; clean, if necessary.	•	•

Fault	Possible cause	Remedy	Specialised personnel	Service technician
Dryer cannot be switched over	Solenoid valve Y1/Y2 cannot be opened.	Check supply voltage, cable, contacts and solenoid; replace, if necessary.	•	•
	Solenoid valve Y1/Y2 cannot be opened properly (audible humming sound or valve flapping).	Check supply voltage. Check spring and solenoid; replace, if necessary.	•	•
	Control board defective.	Check fuse in supply line and in the switchbox; replace, if necessary.	•	•
	Power supply interrupted, cable broken.	Reconnect the unit to the power supply.	•	•
	Compressor might be off.	Check compressor synchronisation circuit.	•	
	Error in control programme.	Restart programme.		•
No expansion	Solenoid valve Y3/Y4 cannot be opened.	Check supply voltage, cable, contacts and solenoid; replace, if necessary.	•	•
	Solenoid valve Y3/Y4 cannot be opened properly (audible humming sound or valve flapping).	Check supply voltage. Check spring and solenoid; replace, if necessary. Check solenoid valve for contamination; clean or replace, if necessary.	•	•
Dryer is continuously bled	Solenoid valve Y3/Y4 cannot be closed properly (audible humming sound or valve flapping).	Check supply voltage. Check spring and solenoid; replace, if necessary. Check diaphragm; replace, if necessary.	•	•
Dryer is excessively bled	Solenoid valve Y1/Y2 cannot be closed	Check solenoid and diaphragm; replace, if necessary.	•	•

With dewpoint-sensing control (optional)

Fault code	Description of fault	Possible cause	Remedy	Specialised personnel	Service technician
+20	Upper measuring range limit exceeded	Drying capacity exceeded.	See instructions for commissioning. If the drying agent is wet, replace it.	•	
		Error in programme.	Restart programme.		
999	Dewpoint sensor defective	Sensor defective or irreversibly contaminated.	Replace sensor.	•	•
sens o -999	Sensor not powered, or cable or sensor defective	Sensor, sensor cable or sensor adapter defective.	Visual inspection; check power supply (24 V to terminals 4 and 6). Replace defective component(s).	•	•
SEr	Display for service interval. Regular maintenance tasks must be carried out.	The display appears after every 8000 operating hours.	Inform the manufacturer's service staff and order the appropriate service kit. The package includes a dongle with which you can reset the operating hours counter after maintenance has been carried out. For instructions on how to use the dongle see the enclosed information sheet (in the service kit).	•	•

Annex with technical documentation

This annex comprises the following information and technical documentation:

- ◇ Technical data
- ◇ Replacement and wear parts list
- ◇ Logic control diagram
- ◇ Flow diagram
- ◇ Dimensional drawing

Technical data

Operating Range

Site Selection	frost-free indoor installation in a non-hazardous environment
Ambient temperature	1,5 to 50 °C (24,7 to 122 °F)
Compressed air inlet temperature	25 to 50 °C (68 to 122 °F)
Max. operating pressure	16 bar _e
Min. operating pressure	5 bar _e
Medium	Compressed air and gaseous nitrogen
Fluid group	2

Electrical connection

Mains voltage, standard	230 V, 50-60 Hz
Alternative voltage	115 V, 50-60 Hz and 24 V DC
Protection class	IP65

Please note type plate and attached electrical circuit diagram!

Performance details

Type	Volumetric flow ¹ in m ³ /h	Nominal ² pipe size	Upstream filter	Downstream filter	Nominal Pressure in bar _e	Nominal temperatur. °C
K-MT 1	8	1/4	AAPX010AGFX	AOPX010AGMX	16	50
K-MT 2	15	1/4	AAPX010AGFX	AOPX010AGMX	16	50
K-MT 3	25	1/4	AAPX010AGFX	AOPX010AGMX	16	50
K-MT 4	35	1/4	AAPX010AGFX	AOPX010AGMX	16	50
K-MT 6	56	1/2	AAPX015AGFX	AOPX015AGMX	16	50
K-MT 7	72	1/2	AAPX015AGFX	AOPX015AGMX	16	50
K-MT 8	86	3/4	AAPX020AGFX	AOPX020AGMX	16	50

¹ . m³/h, relating to 1 bar_e and 20°C at the compressor suction capacity. Subsequently compressed to 7 bar_e and 35°C inlet ..temperature to the dryer at 100% relative humidity – for pressure dewpoints of -25°C and -40°C.

² In accordance with DIN ISO 228 (BSP-P); alternatively ANSI B 1.20.1 (NPT-F).

Noise emission

Noise level : +3 dB (A) ¹	65 – 86 dB(A)
--------------------------------------	---------------

¹.. relative to free field measurement, 1 m surr. field

Dimensions

Please heed to the dimensional drawings and the according table containing dimensions and weight on page 52.

Drying agent

Chamber 1	100 % molecular sieve
Chamber 2	100 % molecular sieve

Replacement and wear part list

Note:

When exchange or replacement parts are ordered, always state the dryer type and the build no. of the dryer. These data are found on the type plate.

Service-kits

For model	Maintenance-interval	Mains-voltage	Order-ID.	Scope of delivery
K-MT 1 to K-MT 4	12 and 36 months	115V, 230V	SKK1-K4/D3/12	Reset-module, muffler and filter elements
K-MT 1 to K-MT 4	24 months	115V, 230V	SKK1-K4/D3/24	Reset- module, valve membranes, muffler and filter elements
K-MT 1 to K-MT 4	48 months	230V	SKK1-K4/D3/48	Reset- module, valve membranes, solenoid coils, check valves, demisters, perforated plates, muffler and filter elements
		115V	SKK1-K4/D3/48/115	
K-MT 6 to K-MT 7	12 and 36 months	115V, 230V	SKK6-K7/D3/12	Reset-module, muffler and filter elements
K-MT 6 to K-MT 7	24 months	115V, 230V	SKK6-K7/D3/24	Reset- module, valve membranes, muffler and filter elements
K-MT 6 to K-MT 7	48 months	230V	SKK6-K7/D3/48	Reset- module, valve membranes, solenoid coils, check valves, demisters, perforated plates, muffler and filter elements
			SKK6-K7/D3/48/115	
K-MT 8	12 and 36 months	115V, 230V	SKK8/D3/12	Reset-module, muffler and filter elements
K-MT 8	24 months	115V, 230V	SKK8/D3/24	Reset- module, valve membranes, muffler and filter elements
K-MT 8	48 months	230V	SKK8/D3/48	Reset- module, valve membranes, solenoid coils, check valves, demisters, perforated plates, muffler and filter elements
			SKK8/D3/48/115	

Desiccant packs (complete dryer)

Order-ID.	K-MT 1	K-MT 2	K-MT 3	K-MT 4	K-MT 6	K-MT 7	K-MT 8
DESPAC1MS	1X		1X			2X	1X
DESPAC4MS		1X	1X	2X			1X
DESPAC15MS					1X	1X	1X

Replacement Element filter : P - TYPE - GRADE

Sample: Filter AAP010AGFI (Element P010AA)

Filter AOP020AGMI (Element P020AO)

Logic control diagram

Adsorption in B1 and regeneration in B2

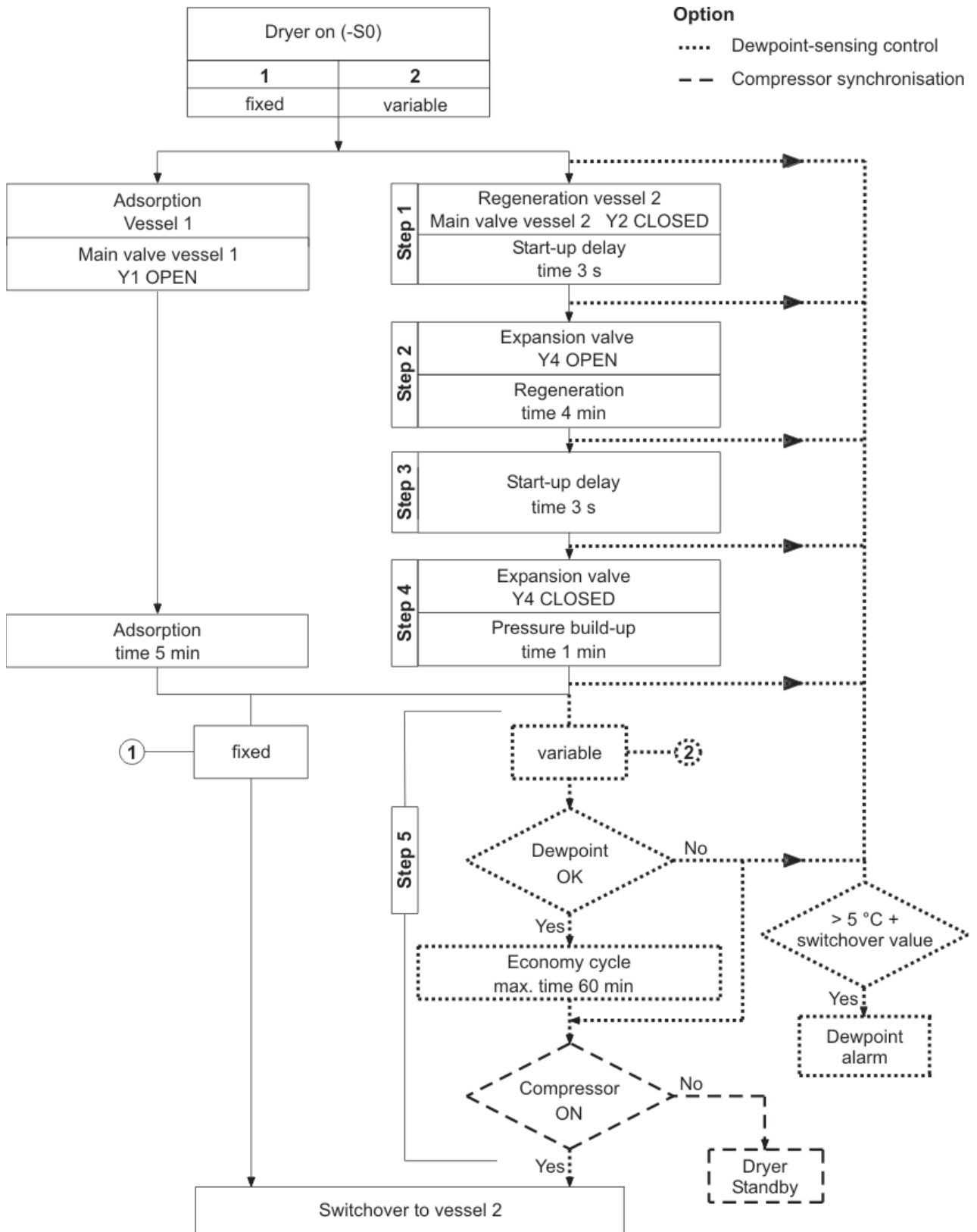

Regeneration in B1 and adsorption in B2

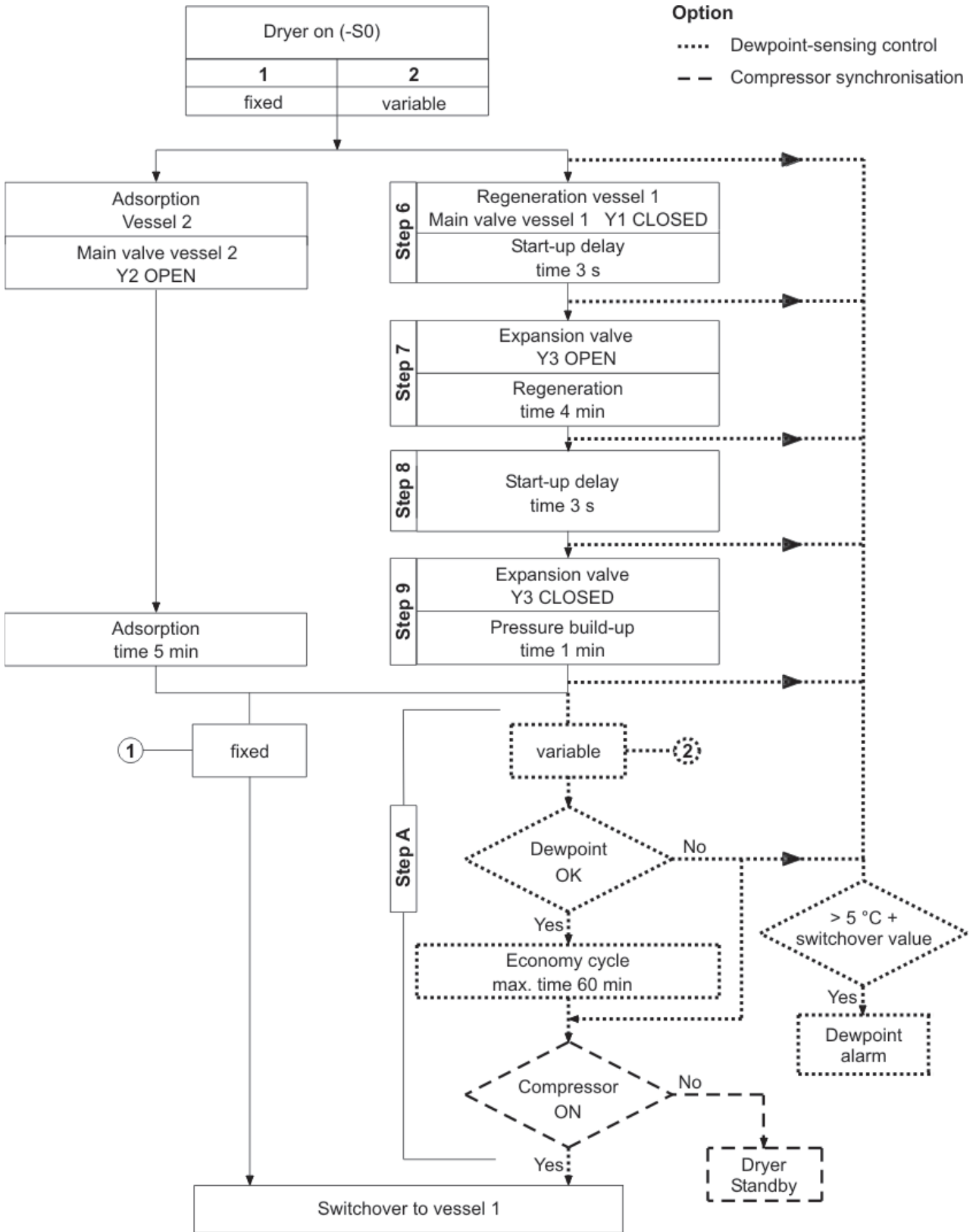

Flow diagram

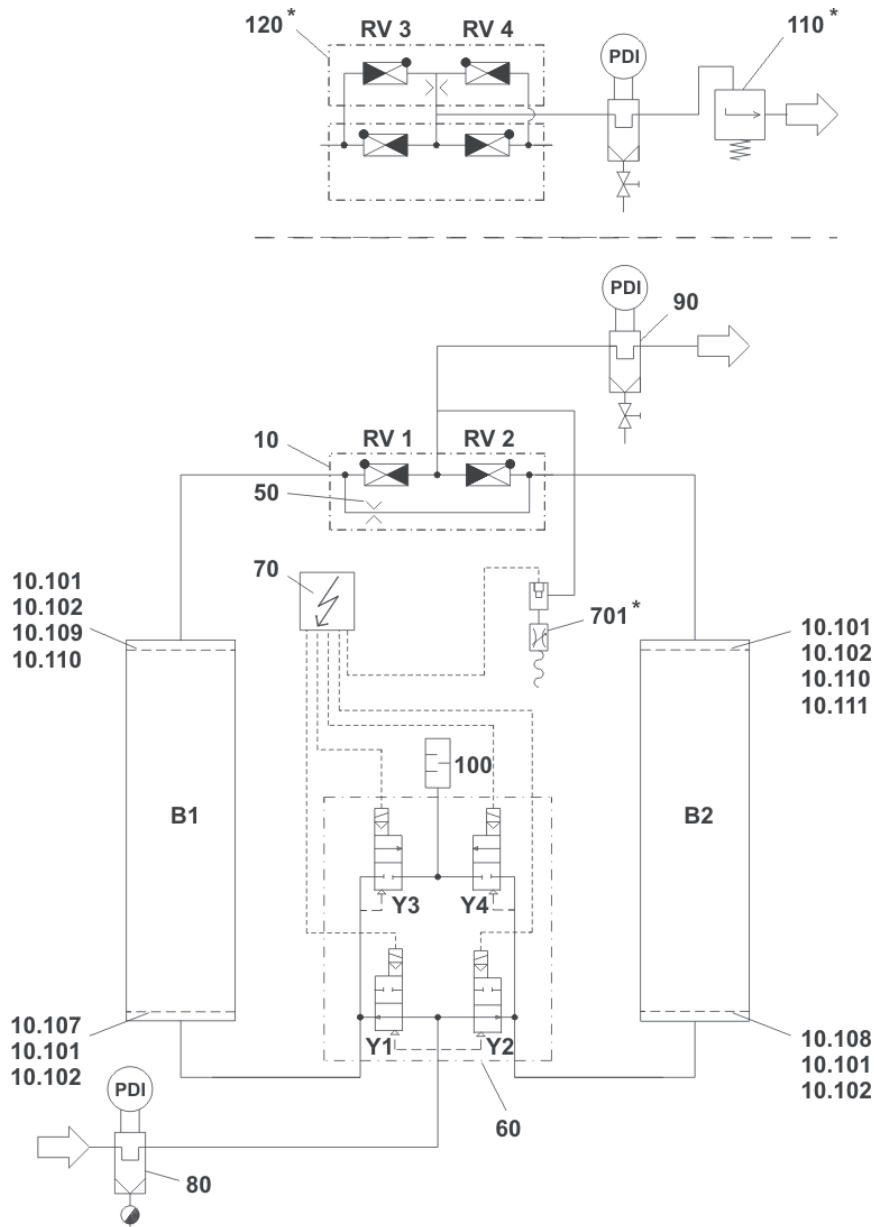

Item	Designation
10	Check valve plate
10.101	Seal
10.102	Perforated plate
10.107	Demister, left
10.108	Demister, right
10.109	Left perforated plate
10.110	Conical pressure spring
10.111	Right perforated plate
50	Regeneration gas orifice plate

Item	Designation
60	Control unit
70	Control system
80	Upstream filter
90	Downstream filter
100	Muffler
*	Optional devices:
110	Start-up device
120	Regeneration gas return line
701	Dewpoint-sensing unit

Dimensional drawing

Installation on floor

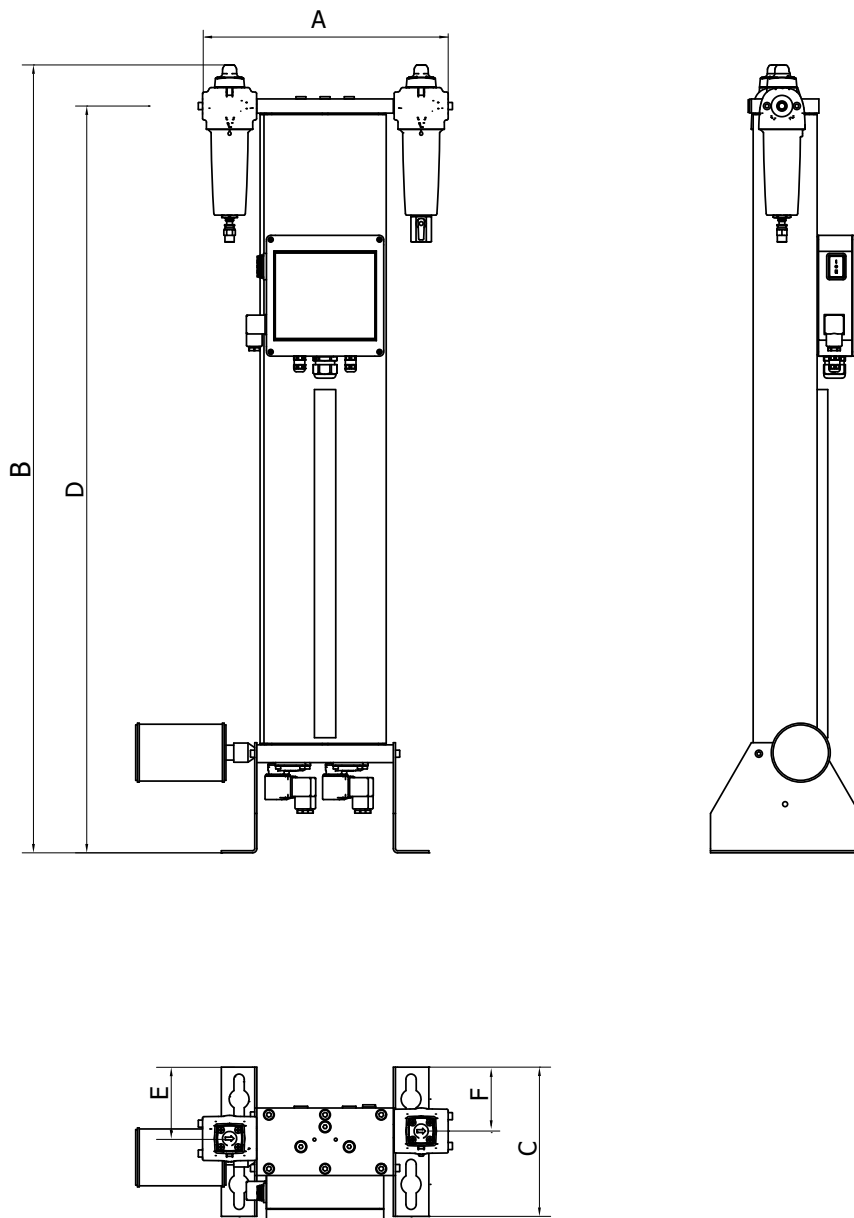

Type	BSP-P/ NPT	Dimensions [mm]						Weight [kg]
		A	B	C	D	E	F	
K-MT 1	1/4"	326	400	216	376	101	90	11,5
K-MT 2	1/4"	326	575	216	551	101	90	15,5
K-MT 3	1/4"	326	825	216	801	101	90	20,0
K-MT 4	1/4"	326	1075	216	1051	101	90	25,0
K-MT 6	1/2"	493	1203	300	1097	132	134	48,0
K-MT 7	1/2"	493	1428	300	1322	132	134	56,5
K-MT 8	3/4"	493	1628	300	1522	132	134	62,5



A division of Parker Hannifin Corporation

Parker Hannifin Manufacturing S.r.l.

Sede Legale:

Via Sebastiano Caboto 1, Palazzina "A" 20094 Corsico (MI) Italy

Sede Operativa:

Gas Separation and Filtration Division EMEA - Strada Zona Industriale, 4

35020 S. Angelo di Piove (PD) Italy

tel +39 049 971 2111- fax +39 049 9701911

Web-site: www.parker.com