

# Clean, Dry Compressed Air

## KA-MT 1 - 8

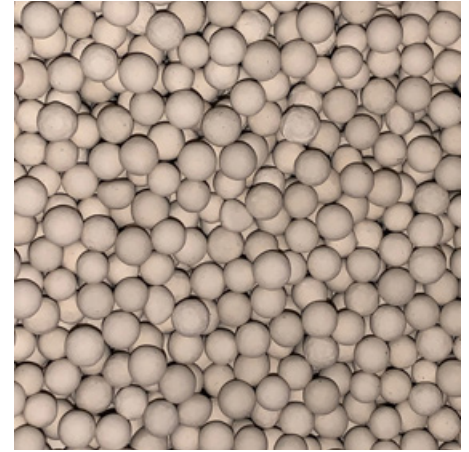

### Adsorption Dryers

Whether a compressed air user wants to control the growth of micro-organisms (essential for direct and in-direct contact applications in the food, beverage & pharmaceutical industries), ensure air used for critical applications / instrumentation is free from water contamination or has external piping where low ambient temperature can cause condensation, adsorption dryers are the go to dryer technology.

There are many different adsorption dryer technologies available and whilst they all reduce water from the compressed air in the same way, they differ in the way they regenerate the desiccant material.

### Heatless Adsorption Dryers

The simplest and most common method used to regenerate the adsorbent desiccant material is the 'heatless' method (so called as it does not use heat for desiccant regeneration).

Using a proportion of the clean, dry process air for regeneration, heatless dryers typically have the lowest capital costs of all adsorption dryer types (due to the simplicity of the heatless design).

Being very robust and having fewer components, they typically have the lowest maintenance cost of all the adsorption technologies.

Heatless dryers are available to suit all compressed air flow rates from small to large, whereas the more complicated regeneration methods are often only available for higher flow rates due to cost and complexity of the designs.



### Advantages

- Parker KA-MT dryers provide a constant outlet dewpoint in accordance with ISO8573-1 classes 1, 2 or 3 for water vapour
- Parker KA-MT dryers provide an outlet dewpoint which inhibits the growth of micro-organisms (allowing their efficient reduction using filtration)
- Parker KA-MT dryers use clean, dry purge air for regeneration, eliminating any risk of damage to the adsorption bed or re-contamination of the downstream compressed air
- No heat is used for regeneration; therefore, no insulation is required and loss of dewpoint on column changeover due to inefficient cool down is eliminated
- Parker KA-MT dryers include Parker OIL-X High Efficiency Coalescing pre-filtration, Oil Vapour Reduction Stage and General Purpose Dry Particulate post filtration as standard
- Fitted with Parker Multitronic electronic control with the option of dewpoint display and dewpoint switching Energy Saving Technology



ENGINEERING YOUR SUCCESS.

## Dryer Performance

Dryer Models	Dewpoint (Standard)		ISO8573-1:2010 Classification (Standard)	Dewpoint (Option 1)		ISO8573-1:2010 Classification (Option 1)	Dewpoint (Option 2)		ISO8573-1:2010 Classification (Option 2)
	°C	°F		°C	°F		°C	°F	
KA-MT 1 - 8	-40	-40	Class 2.2.1	-70	-100	Class 2.1.1	-25	-13	Class 2.3.1

## Technical Data

Dryer Models	Minimum Operating Pressure		Maximum Operating Pressure		Minimum Operating Temperature		Maximum Operating Temperature		Maximum Ambient Temperature		Electrical Supply (Standard)	Electrical Supply (Optional)	Thread Type	Noise Level dB(A)
	bar g	psi g	bar g	psi g	°C	°F	°C	°F	°C	°F				
KA-MT 1 - 8	4	58	16	232	5	41	50	122	50	122	230V 1ph 50/60Hz	115V 1ph 50/60Hz or 24V DC	BSPP	65-86

## Flow Rates

Model	Pipe Size BSP	Inlet Flow Rate			
		L/s	m³/min	m³/hr	cfm
KA-MT 1	G 1/4	2	0.13	8	5
KA-MT 2	G 1/4	4	0.25	15	9
KA-MT 3	G 1/4	7	0.42	25	15
KA-MT 4	G 1/4	10	0.58	35	21
KA-MT 6	G 1/2	16	0.93	56	33
KA-MT 7	G 1/2	20	1.2	72	42
KA-MT 8	G 3/4	24	1.43	86	51

Inlet flow rate relating to 1 bar(a) and 20 °C; relating to the suction performance of the compressor, compression at 7 bar(g) and 35 °C dryer inlet temperature, at 25 °C ambient temperature, 60 % relative humidity.

## Product Selection & Correction Factors

For correct operation, compressed air dryers must be sized using for the maximum (summer) inlet temperature, maximum (summer) ambient temperature, minimum inlet pressure, required outlet dewpoint and maximum flow rate of the installation.

To select a dryer, first calculate the MDC (Minimum Drying Capacity) using the formula below then select a dryer from the flow rate table above with a flow rate equal to or above the MDC.

$$\text{Minimum Drying Capacity} = \text{System Flow} \times \text{CFIT} \times \text{CFAT} \times \text{CFMIP} \times \text{CFOD}$$

### CFIT - Correction Factor Maximum Inlet Temperature

Maximum Inlet Temperature	°C	25	30	35	40	45	50
	°F	77	86	95	104	113	122
Correction Factor		0.94	0.95	1.00	1.15	1.22	1.28

### CFAT - Correction Factor Maximum Ambient Temperature

Maximum Ambient Temperature	°C	25	30	35	40	45	50
	°F	77	86	95	104	113	122
Correction Factor		1.00	1.00	1.00	1.00	1.00	1.00

### CFMIP - Correction Factor Minimum Inlet Pressure

Minimum Inlet Pressure	bar g	4	5	6	7	8	9	10	11	12	13	14	15	16
	psi g	58	73	87	100	116	131	145	160	174	189	203	218	232
Correction Factor		1.60	1.33	1.12	1.00	0.88	0.79	0.76	0.74	0.67	0.62	0.59	0.56	0.53

### CFOD - Correction Factor Outlet Dewpoint

Outlet Dewpoint	°C	-25	-40	-70
	°F	-13	-40	-100
Correction Factor		1.00	1.00	2.00

## Controller Functions

Dryer Models	Controller Function							
	Power On Indication	Visual Fault Indication	Dewpoint Display	DDS - Energy Saving Technology	Filter Service Indicator	Dryer Service Indicator	Fault Relay: Power Loss Dewpoint Alarm Sensor Failure	4-20mA Dewpoint Re-transmission
KA-MT 1 - 8	•					•		
Optional Dewpoint Sensor	•		•	•		•	•	Optional

## Included Filtration

Model	Dryer Inlet	Dryer Outlet	
	High Efficiency Filter	General Purpose Dry Particulate Filter	High Efficiency Dry Particulate Filter (Option)
KA-MT 1	AAPX010A	AOPX010A	AAPX010A
KA-MT 2	AAPX010A	AOPX010A	AAPX010A
KA-MT 3	AAPX010A	AOPX010A	AAPX010A
KA-MT 4	AAPX010A	AOPX010A	AAPX010A
KA-MT 6	AAPX015C	AOPX015C	AAPX015C
KA-MT 7	AAPX015C	AOPX015C	AAPX015C
KA-MT 8	AAPX020D	AOPX020D	AAPX020D

Included in standard scope of supply:  
 Prefilter (AA) including float drain.  
 Afterfilter (AO) including manual drain.

Optional: (Delivered separately):  
 Oil vapour reduction filter (ACS)  
 High efficiency dry particulate filter (AA) including manual drain

## Filtration Performance

	High Efficiency Filter	General Purpose Dry Particulate Filter	Oil Vapour Reduction Filter	High Efficiency Dry Particulate Filter
Filtration Grade	Grade AA	Grade AO	AKM	Grade AA
Filtration Type	Coalescing	Dry Particulate	Adsorption	Dry Particulate
Particle Reduction (inc water & oil aerosols)	Down to 0.01 micron	Down to 1 micron	N/A	Down to 0.01 micron
Maximum Remaining Oil Aerosol Content at 21°C	≤0.01 mg/m <sup>3</sup> (≤0.01 ppm(w))	N/A	≤0.003 mg/m <sup>3</sup> (≤0.003 ppm(w))	N/A
Maximum Remaining Oil Vapour Content at System Temperature	N/A	N/A	N/A	N/A
Filtration Efficiency	99.9999%	99.925%	N/A	99.9999%

## Weights & Dimensions

Model	Pipe Size BSPP or NPT	Dimensions						Weight	
		Height (H)		Width (W)		Depth (D)		kg	lbs
		mm	ins	mm	ins	mm	ins		
KA-MT 1	¼"	434	17	486	19	210	8	15	33
KA-MT 2	¼"	609	24	477	19	210	8	20	44
KA-MT 3	¼"	859	34	577	23	210	8	28	62
KA-MT 4	¼"	1109	44	577	23	210	8	35	77
KA-MT 6	½"	1164	55	692	27	300	12	68	150
KA-MT 7	½"	1389	55	692	27	300	12	81	179
KA-MT 8	¾"	1589	63	692	27	300	12	92	203

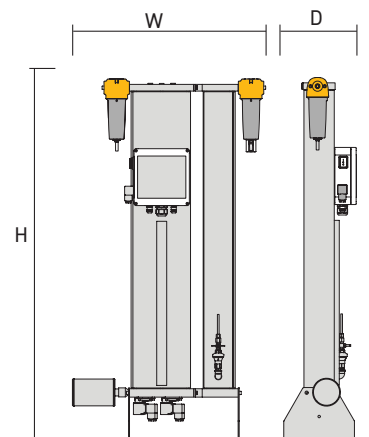

## Quality Assurance / IP Rating / Pressure Vessel Approvals

Development / Manufacture	ISO 9001 / ISO 14001
Ingress Protection Rating	IP65 Indoor and frost free installation only
EU	Pressure vessel approved for fluid group 2 in accordance with the Pressure Equipment Directive 2014/68/EU
USA	Approval to ASME VIII Div. 1 not required
AUS	Approval to AS1210 not required
Russia	TR (formerly GOST-R)
<b>For use with Compressed Air Only</b>	

# Parker Worldwide

## Europe, Middle East, Africa

### AE – United Arab Emirates,

Dubai

Tel: +971 4 8127100

### AT – Austria, St. Florian

Tel: +43 (0)7224 66201

### AZ – Azerbaijan, Baku

Tel: +994 50 2233 458

### BE/NL/LU – Benelux,

Hendrik Ido Ambacht

Tel: +31 (0)541 585 000

### BY – Belarus, Minsk

Tel: +48 (0)22 573 24 00

### CH – Switzerland, Etoy

Tel: +41 (0)21 821 87 00

### CZ – Czech Republic,

Prague

Tel: +420 284 083 111

### DE – Germany, Kaarst

Tel: +49 (0)2131 4016 0

### DK – Denmark, Ballerup

Tel: +45 43 56 04 00

### ES – Spain, Madrid

Tel: +34 902 330 001

### FI – Finland, Vantaa

Tel: +358 (0)20 753 2500

### FR – France, Contamine s/Arve

Tel: +33 (0)4 50 25 80 25

### GR – Greece

Tel: +30 69 44 52 78 25

### HU – Hungary, Budaörs

Tel: +36 23 885 470

### IE – Ireland, Dublin

Tel: +353 (0)1 466 6370

### IL – Israel

Tel: +39 02 45 19 21

### IT – Italy, Corsico (MI)

Tel: +39 02 45 19 21

### KZ – Kazakhstan, Almaty

Tel: +7 7273 561 000

### NO – Norway, Asker

Tel: +47 66 75 34 00

### PL – Poland, Warsaw

Tel: +48 (0)22 573 24 00

### PT – Portugal

Tel: +351 22 999 7360

### RO – Romania, Bucharest

Tel: +40 21 252 1382

### RU – Russia, Moscow

Tel: +7 495 645-2156

### SE – Sweden, Borås

Tel: +46 (0)8 59 79 50 00

### SL – Slovenia, Novo Mesto

Tel: +386 7 337 6650

### TR – Turkey, Istanbul

Tel: +90 216 4997081

### UK – United Kingdom, Warwick

Tel: +44 (0)1926 317 878

### ZA – South Africa, Kempton Park

Tel: +27 (0)11 961 0700

## North America

### CA – Canada, Milton, Ontario

Tel: +1 905 693 3000

### US – USA, Cleveland

Tel: +1 216 896 3000

## Asia Pacific

### AU – Australia, Castle Hill

Tel: +61 (0)2-9634 7777

### CN – China, Shanghai

Tel: +86 21 2899 5000

### HK – Hong Kong

Tel: +852 2428 8008

### IN – India, Mumbai

Tel: +91 22 6513 7081-85

### JP – Japan, Tokyo

Tel: +81 (0)3 6408 3901

### KR – South Korea, Seoul

Tel: +82 2 559 0400

### MY – Malaysia, Shah Alam

Tel: +60 3 7849 0800

### NZ – New Zealand, Mt Wellington

Tel: +64 9 574 1744

### SG – Singapore

Tel: +65 6887 6300

### TH – Thailand, Bangkok

Tel: +662 186 7000

### TW – Taiwan, Taipei

Tel: +886 2 2298 8987

## South America

### AR – Argentina, Buenos Aires

Tel: +54 3327 44 4129

### BR – Brazil, Sao Jose dos Campos

Tel: +55 080 0727 5374

### CL – Chile, Santiago

Tel: +56 22 303 9640

### MX – Mexico, Toluca

Tel: +52 72 2275 4200



### EMEA Product Information Centre

Free phone: 00 800 27 27 5374

(from AT, BE, CH, CZ, DE, DK, EE, ES, FI, FR, IE, IL, IS, IT, LU, MT, NL, NO, PL, PT, RU, SE, SK, UK, ZA)

### US Product Information Centre

Toll-free number: 1-800-27 27 537

[www.parker.com/gsf](http://www.parker.com/gsf)