

NITROSource COMPACT PSA Nitrogen Gas Generator

NITROSource Compact nitrogen gas generators from Parker produce a totally on-demand nitrogen gas supply from a standard factory compressed air supply. A safe and reliable alternative to delivered gas options, the compact and lightweight modular design provides a consistent and easy to maintain solution for low to medium flow rate on-site gas requirements.

When maintained in-line with Parker's recommendations, NITROSource Compact will offer in excess of 10 years service life its Carbon Molecular Sieve (CMS), the material which it uses to separate nitrogen from compressed air.

NITROSource Compact has been designed to meet multiple industry compliance including CU TR (EAC), CE, UL, CRN and has third party verified FDA Article 21 and European Food and Pharmaceutical approval. NITROSource Compact is also exempt from annual PED pressure vessel inspection resulting in minimum disruption to production.

NITROSource Compact is the ideal replacement to delivered nitrogen gas, eliminating the issues of administration, logistics and the potential risk of running out of gas associated with high pressure cylinders, liquid mini tanks or bulk storage vessels.

Key Features and Benefits

■ Lower cost maintenance, extensive working life

Carbon Molecular Sieve, the 'engine' of the generator delivers nitrogen more efficiently, leading to a very long working life – and major savings on maintenance.

■ Gas quality control

- **Mass Flow Controller** - ensuring correct set pressure and flow.
- **Integral Oxygen Analyser** - constantly measures gas purity.
- **Off-Gas-By-Pass** - automatically vents off out-of-specification gas ensuring product quality by ensuring gas quality.
- **Outlet Pressure Regulation** - to ensure correct pressure to the application.
- **Electronic Control System** - 100% management of all critical generator functions.

■ Remote monitoring

Enabling connection to proprietary remote management and the generator control systems to control and track gas parameters from a central location.

■ Industry compliance

Food and pharmaceutical safe, in line with European statute (EIGA) and the USA Food & Drugs Administration (FDA Article 21) and Pharmacopeia compliance.

■ Five year warranty

Free through Parker extended warranty, offering the assurance of no unexpected maintenance costs and maximised factory up-time*.

* Subject to terms and conditions. Please contact your local authorised Parker distributor.



Technical Specifications

Flow Rates Stated flows are for operation at 7 bar g (100 psi g / 0.7 MPa g) with reference to 25 °C

Model	Purity (Remaining Oxygen Content) vs Nitrogen Outlet Flow Rate (m³/hr)											
	10ppm	50ppm	100ppm	250ppm	500ppm	0.1%	0.5%	1.0%	2.0%	3.0%	4.0%	5.0%
N2C-02	0.8	1.2	1.5	1.8	2.1	2.5	3.7	4.4	6.1	7.7	9.1	10.3
N2C-04	1.7	2.4	2.9	3.5	4.2	5.0	7.6	9.1	13.0	15.9	18.4	20.6
N2C-06	2.4	3.9	4.5	5.7	6.5	7.6	11.1	13.3	18.6	22.7	26.1	29.0
N2C-08	3.4	5.0	5.9	7.4	8.7	10.2	14.9	18.0	24.0	29.3	33.9	37.8
N2C-10	4.2	6.2	7.3	9.1	10.8	12.8	18.6	22.5	30.0	36.6	42.4	47.2

Weights & Dimensions

Model	Height (H)		Width (W)		Depth (D)		Weight	
	mm	ins	mm	ins	mm	ins	kg	lbs
N2C-02	1040	40.9	450	17.7	458	18.0	136	299.8
N2C-04	1040	40.9	450	17.7	628	24.7	188	414.4
N2C-06	1040	40.9	450	17.7	796	31.3	246	542.3
N2C-08	1040	40.9	450	17.7	965	37.9	303	667.9
N2C-10	1040	40.9	450	17.7	1134	44.6	360	793.6

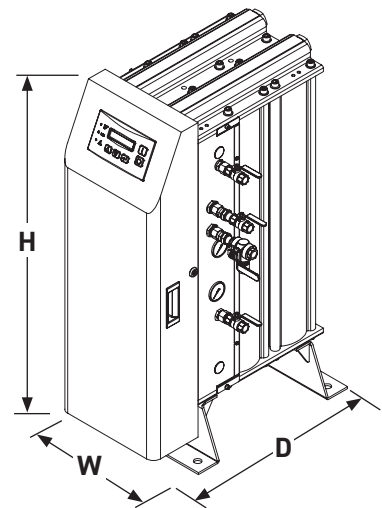

Operating Parameters

Minimum Inlet Air Quality	ISO 8573-1: 2010 Class 2.4.1	
Minimum Operating Pressure	6.0 bar(g)	87.0 psi(g)
Maximum Operating Pressure	10.0 bar(g)	145.0 psi(g)
Design Pressure	10.0 bar(g)	145.0 psi(g)
Minimum Operating Temp.	5.0°C	41.0°F
Maximum Operating Temp.	50.0°C	122.0°F
Supply Voltage	100-240V AC (±10%) 50/60Hz	
IP Rating	IP20	NEMA 1
Average Noise @ 7.0bar(g)	~80 dB (A)	

Pipe Connections

Compressed Air Inlet	½" BSPP
To Buffer Vessel	½" BSPP
From Buffer Vessel	½" BSPP
Nitrogen Outlet	½" BSPP

Part Number Configurator

Configurator	N	2	C	-	<input type="text"/>	<input type="text"/>	-	<input type="text"/>	<input type="text"/>	-	0	0	A
--------------	---	---	---	---	----------------------	----------------------	---	----------------------	----------------------	---	---	---	---

Model	Prefix	Purity	Prefix	Oxygen Analyser Technology	Prefix
N2C-02	0 2	10ppm / 50ppm	U	Electrochemical	E
N2C-04	0 4	100ppm / 250ppm / 500ppm / 0.1%	H	Zirconia	Z
N2C-06	0 6	0.5% / 1.0% / 2.0% / 3.0% / 4.0% / 5.0%	L		
N2C-08	0 8				
N2C-10	1 0				

Minimum Buffer Vessel Size

Outlet Flow Rate m³/hr	Capacity	
≤3.0	50 Litres	13 Gallon
3.1 - 7.5	150 Litres	39 Gallon
7.6 - 12.3	250 Litres	66 Gallon
12.4 - 24.0	500 Litres	132 Gallon
24.1 - 45.0	750 Litres	198 Gallon
>45.0	1000 Litres	264 Gallon

Recommended minimum buffer vessel size to guarantee maximum outlet pressure.

Utilisation of smaller buffer vessels may result in lower outlet pressures and fluctuations in purity.

Parker Hannifin Corporation
Gas Separation and Filtration Division EMEA
 Dukesway, Team Valley Trading Estate
 Gateshead, Tyne & Wear, United Kingdom

www.parker.com/gsf

Reference: PISNITROSOURCEC-02-EN

© 2025 Parker Hannifin Corporation

