



DNS3-201

## DNS/VNS

### Pressure switches and vacuum switches with stainless steel sensors (1.4571)

Pressure switches of the DNS series are suitable for monitoring and controlling pressures in chemical plants, process engineering and any situation where the pressure of aggressive liquids and gases must be monitored.

All components of the sensor system are made of high quality stainless steel (1.4571) and welded using the latest methods without filler metals. The pressure sensor is gasket free plasma welded.

SIL 2 according IEC 61508-2



#### Technical data

##### Pressure connection

External thread G 1/2 (pressure gauge connection) according to DIN 16 288 and internal thread G 1/4 according to ISO 228 Part 1.

##### Switching device

Robust housing (200) made of seawater resistant die cast aluminium GD Al Si 12.

##### Protection class

IP 54, in vertical position.

##### Pressure sensor materials

Pressure bellows and all parts in contact with medium. X 6 Cr Ni Mo Ti 17122 Material no. 1.4571

##### Mounting position

Vertically upright and horizontal.

##### Max. ambient temperature at switching device

-25...+70 °C.

##### Max. medium temperature

The maximum medium temperature at the pressure sensor must not exceed the permitted ambient temperature at the switching device. Temperatures may reach 85°C for short periods.

Higher medium temperatures are possible provided the above limit values for the switching device are ensured by suitable measures (e.g. siphon).

##### Mounting

Directly on the pressure line (pressure gauge connection) or on a flat surface with two 4 mm Ø screws.

##### Switching pressure

Adjustable from outside with screw driver.

##### Switching differential

For values see Product Summary.

##### Contact arrangement

Single pole change over switch.

Switching capacity	250 VAC		250 VDC	24 VDC
	(ohm)	(ind)	(ohm)	(ohm)
Normal	8 A	5 A	0.3 A	8 A

##### Plastic coating

The diecast aluminium housing in GD Al Si is chromated and stove enamelled with resistant plastic. Corrosion tests with 3% saline solution and 30 temperature changes from +10 to +80°C showed no surface changes after 20 days.

#### Product Summary

Type	Setting range	Switching differential (mean values)	Max. permissible pressure	Dimensioned drawing
<b>Switching differential not adjustable</b>				<b>page 25 + 26</b>
VNS301-201	-250...+100 mbar	45 mbar	3 bar	
VNS111-201	-1*...+0.1 bar	50 mbar	6 bar	
DNS025-201	0.04...0.25 bar	30 mbar	6 bar	1 + 15
DNS06-201	0.1...0.6 bar	40 mbar	6 bar	
DNS3-201	0.2...2.5 bar	0.1 bar	16 bar	
DNS6-201	0.5...6 bar	0.15 bar	16 bar	1 + 18
DNS10-201	1...10 bar	0.3 bar	16 bar	
DNS16-201	3...16 bar	0.5 bar	25 bar	1 + 16
<b>Switching differential adjustable</b>				
VNS111-203	-1*...+0.1 bar	90 -550 mbar	6 bar	
DNS025-203	0.04...0.25 bar	60 -300 mbar	6 bar	1 + 15
DNS06-203	0.1...0.6 bar	80 -400 mbar	6 bar	
DNS3-203	0.2...2.5 bar	0.15- 1.5 bar	16 bar	
DNS6-203	0.5...6 bar	0.25- 2.0 bar	16 bar	1 + 18
DNS10-203	1...10 bar	0.45- 2.5 bar	16 bar	
DNS16-203	3...16 bar	0.8- 3.5 bar	25 bar	1 + 16

\* At very high vacuums, close to the theoretical maximum of -1 bar, the switch may not be usable in view of the special conditions of vacuum engineering. However, the pressure switch itself will not be damaged at maximum vacuum.

#### Calibration

The DNS and VNS series are calibrated for falling pressure. This means that the adjustable switching pressure on the scale corresponds to the switching point at falling pressure. The reset point is higher by the amount of the switching differential. (See also page 27, 1. Calibration at lower switching point).

-DNS/VNS  
see page 66



DNS6-351

## DNS/VNS

### Pressure and vacuum switches with stainless steel sensors (1.4571)

#### Chemical version (switching housing with surface protection)

Pressure switches of the DNS series are suitable for monitoring and controlling pressures in chemical plants, process engineering and any situation where the pressure of aggressive

liquids and gases must be monitored. All components of the sensor system are made from highquality stainless steel (1.4571) and welded using the latest methods without filler metals. The pressure sensor is gasket free plasma welded.



SIL 2 according IEC 61508-2

#### Technical data

<b>Pressure connection</b>	External thread G 1/2" (pressure gauge connection) according to DIN 16 288 and internal thread G 1/4" according to ISO 228 Part 1
<b>Switching device</b>	Robust housing (300) made of seawater-resistant die cast aluminium GD Al Si 12
<b>Protection class</b>	IP 65, in vertical position
<b>Pressure sensor materials</b>	Pressure bellows and all parts in contact with medium X 6 Cr Ni Mo Ti 17122 Material no. 1.4571
<b>Mounting position</b>	Vertically upright and horizontal
<b>Max. ambient temperature at switching device</b>	-25 to +70 °C
<b>Max. medium temperature</b>	The maximum medium temperature at the pressure sensor must not exceed the permitted ambient temperature at the switching device. Temperatures may reach 85 °C for short periods. Higher medium temperatures are possible provided the upper limit at the switching device is ensured by suitable measures (e.g. siphon).
<b>Plastic coating</b>	The die cast aluminium housing in GD Al Si is chromated and stove-enamelled with resistant plastic. Corrosion tests with 3% saline solution and 30 temperature changes from +10 to +80°C showed no surface changes after 20 days
<b>Contact arrangement</b>	Single pole change over switch

Switching capacity	250 VAC (ohm)   (ind)	250 VDC (ohm)	24 VDC (ohm)
Normal	8 A	5 A	0.3 A

Type	Setting range	Switching differential (mean value)	Max. permissible pressure	Dimensioned drawing
<b>Hysteresis not adjustable</b>				<b>page 25 + 26</b>
<b>VNS301-351</b>	-250...+100 mbar	45 mbar	3 bar	
<b>VNS111-351</b>	-1*...+0,1 bar	50 mbar	6 bar	
<b>DNS025-351</b>	0,04...0,25 bar	30 mbar	6 bar	2 + 15
<b>DNS06-351</b>	0,1...0,6 bar	40 mbar	6 bar	
<b>DNS1-351</b>	0,2...1,6 bar	60 mbar	6 bar	
<b>DNS3-351</b>	0,2...2,5 bar	0,1 bar	16 bar	2 + 18
<b>DNS6-351</b>	0,5...6 bar	0,15 bar	16 bar	
<b>DNS10-351</b>	1...10 bar	0,3 bar	16 bar	2 + 16
<b>DNS16-351</b>	3...16 bar	0,5 bar	25 bar	

\* At very high vacuums, close to the theoretical maximum of -1 bar, the switch may not be usable in view of the special conditions of vacuum engineering. However, the pressure switch itself will not be damaged at maximum vacuum.

#### Calibration

The **DNS** and **VNS** series are calibrated for falling pressure. This means that the adjustable switching pressure on the scale corresponds to the switching point at falling pressure. The reset point is higher by the amount of the switching differential. (See also page 27, 1. Calibration at lower switching point).

 DNS/VNS  
see page 66

# Mechanical pressure switches

Technical features / Advantages

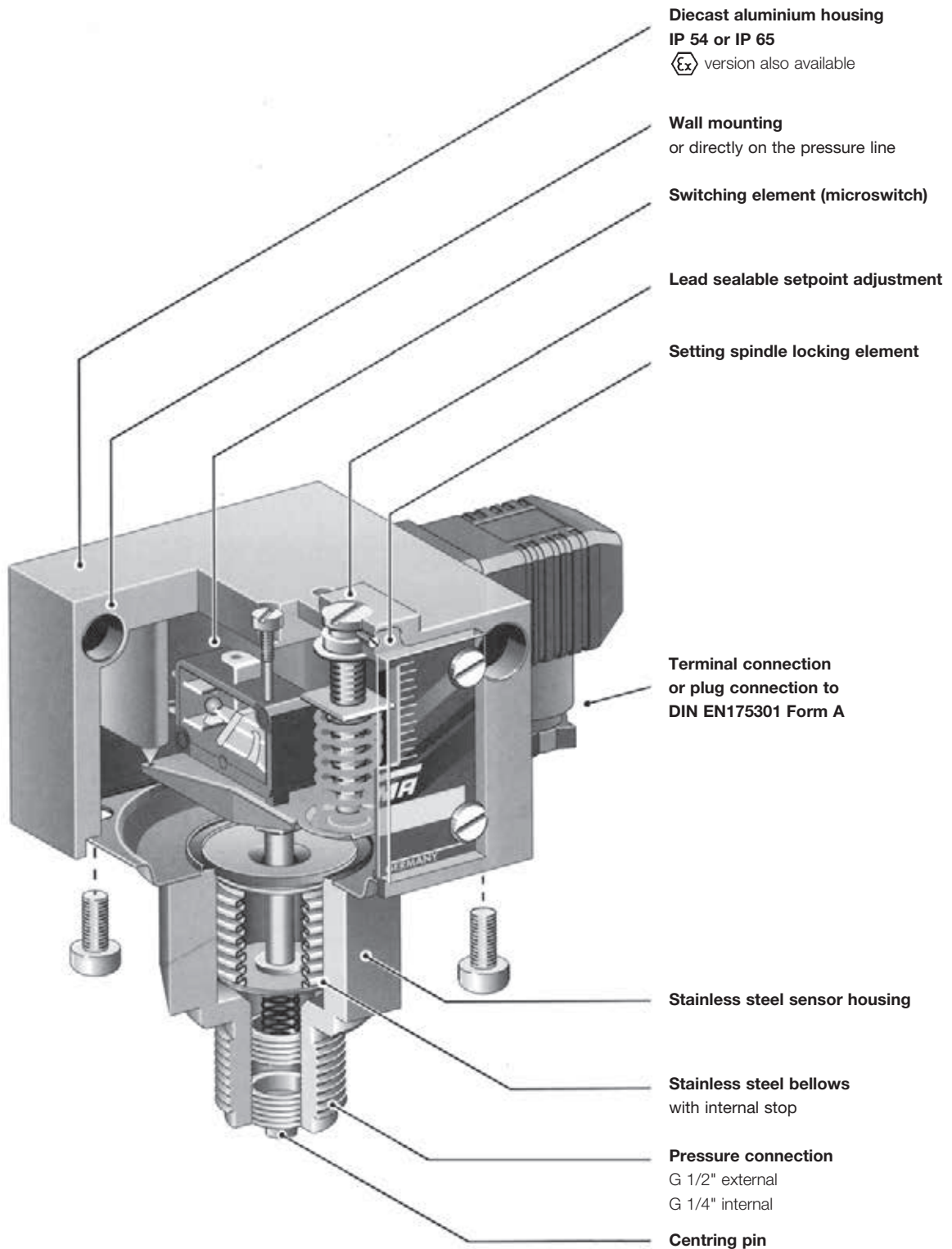

## Definitions

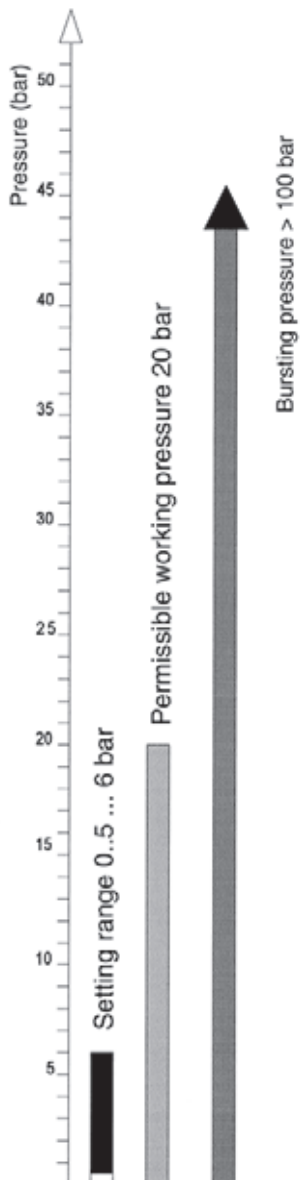
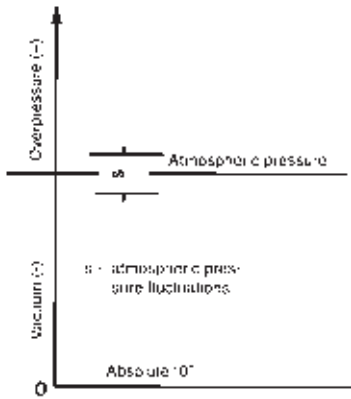

### Pressure data for a pressure switch based on the example of DWR625:

Setting range: 0.5-6 bar  
Perm. working pressure: 20 bar  
Bursting pressure: >100 bar

### Pressure data

- Overpressure** Pressure **over** the relevant atmospheric pressure. The reference point is atmospheric pressure.
- Vacuum** Pressure **under** the relevant atmospheric pressure. The reference point is atmospheric pressure.
- Absolute pressure** Overpressure relative to absolute vacuum.
- Differential pressure** Difference in pressure between 2 pressure measuring points.
- Relative pressure** Overpressure or vacuum relative to atmospheric pressure.

### Pressure data in all FEMA documents refers to relative pressure.

That is to say, it concerns pressure differentials relative to atmospheric pressure. Overpressures have a positive sign, vacuums a negative sign.

#### Permissible working pressure (maximum permissible pressure)

The maximum working pressure is defined as the upper limit at which the operation, switching reliability and water tightness are in no way impaired (for values see Product summary).

#### Bursting pressure (test pressure)

Type-tested products undergo a pressure test certified by TÜV affirming that the bursting pressure reaches at least the values mentioned in the Product summary. During the pressure tests the measuring bellows are permanently deformed, but the pressurized parts do not leak or burst. The bursting pressure is usually a multiple of the permissible working pressure.

#### Setting range

Pressure range in which the cutoff pressure can be set with the setting spindle.

#### Pressure units

Unit	bar	mbar	Pa	kPa	MPa	(psi) lb/m <sup>2</sup>
<b>1 bar</b>	1	1000	10 <sup>5</sup>	100	0.1	14.5
<b>1 mbar</b>	0.001	1	100	0.1	10 <sup>-4</sup>	0.0145
<b>1 Pa</b>	10 <sup>-5</sup>	0.01	1	0.001	10 <sup>-6</sup>	1.45 · 10 <sup>-4</sup>
<b>1 kPa</b>	0,01	10	1000	1	0.001	0,145
<b>1 MPa</b>	10	10 <sup>4</sup>	10 <sup>6</sup>	1000	1	145

In FEMA documents pressures are stated in **bar** or **mbar**.

#### Important:

**All pressure data refers to overpressures or vacuums relative to atmospheric pressure. Overpressures have a positive sign, vacuums a negative sign.**

# Definitions

## Maximum pressure monitoring

$RSP = SP - xd$

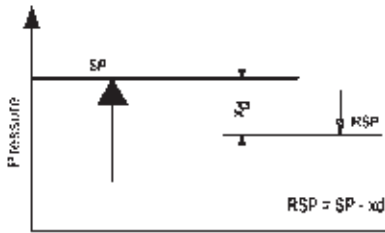

SP = switching point RSP = reset point  
xd = switching differential (hysteresis)

## Minimum pressure monitoring

$RSP = SP + xd$

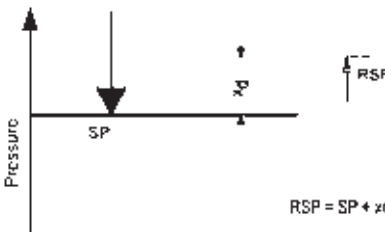

SP = switching point RSP = reset point  
xd = switching differential (hysteresis)

## Switching differential

The switching differential (hysteresis) is the difference in pressure between the **switching point (SP)** and the **reset point (RSP)** of a pressure switch. Switching differential tolerances occur due to tolerances in the microswitches, springs and pressure bellows. Therefore the data in the product summaries always refers to average values. In the case of limiter functions the switching differential has no significance, as one is only interested in the switching point at which cutoff occurs, not the reset point. For a **controller function**, i. e. in the case of pressure switches used to switch a burner, pump etc. **on and off**, a pressure switch with an **adjustable switching differential** should be chosen. The switching frequency of the burner or pump can be varied by changing the switching differential.

## Adjustable switching differential/ calibration

In the case of pressure switches with adjustable switching differential, the hysteresis can be set within the specified limits. The switching point (SP) and reset point (RSP) are precisely definable. When setting the pressure switch, the switching differential situation and the type of factory calibration must be taken into account. Some pressure switches (e.g. minimum pressure monitors of the DCM series) are calibrated under "falling" pressure, i.e. switching under falling pressure takes place at the scale value with the switching differential being above it. The device switches back at scale value + switching differential. If the pressure switch is calibrated under rising pressure, switching takes place at the scale value and the device switches back at scale value - switching differential (see direction of action). The calibration method is indicated in the data sheets.

## Direction of action

In principle, any pressure switch can be used for both maximum pressure and minimum pressure monitoring. This excludes pressure limiters, whose direction of action (maximum or minimum) is predefined. The only thing to remember is that the scale reading may deviate by the amount of the switching differential. See example at bottom left: The scale value is 2.8 bar.

## Maximum pressure monitoring

**With rising pressure**, switching takes place once the preset switching pressure is reached (SP). The reset point (RSP) is lower by the amount of the switching differential.

## Minimum pressure monitoring

**With falling pressure**, switching takes place once the preset switching pressure is reached (SP). The reset point (RSP) is higher by the amount of the switching differential.

## Direction of action in vacuum range

It is particularly important to define the direction of action in the vacuum range. Rising does not mean a rising vacuum, but rising pressure (as viewed from absolute "0"). "Falling" pressure means a rising vacuum. For example: Vacuum switch set to -0.6 bar falling means: Switching (SP) takes place under falling pressure (rising vacuum) at -0.6 bar. The reset point is higher by the amount of the switching differential (e.g. at -0.55 bar).

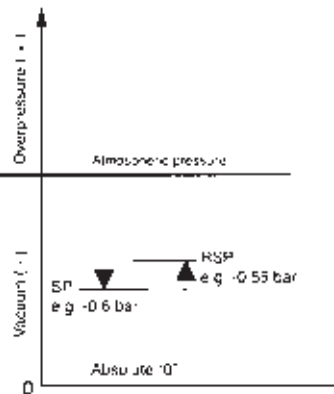

## Setting a pressure switch

To define the switching point of a pressure switch exactly, it is necessary to determine the direction of action in addition to the pressure. "Rising" means that switching takes place at the set value when the pressure rises. The reset point is then lower by the amount of the switching differential. "Falling" means exactly the opposite.

## Please note when specifying the setting of a pressure switch:

In addition to the switching point it is also necessary to specify the direction of action (falling or rising).

## Example for selection of a pressure switch:

A pump is to be turned on at 2.8 bar and off again at 4.2 bar.  
Chosen type: DCMV6 according to data sheet DCM. Setting: Scale pointer to 2.8 bar (lower switching point). Switching differential to 1.4 bar (set according to pressure gauge).  
Cutoff point: 2.8 bar + 1.4 bar = 4.2 bar.

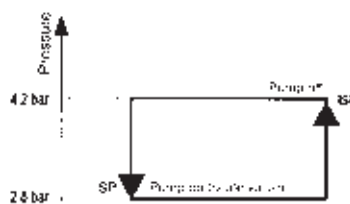

SP = switching point RSP = reset point

### Operating mode

The pressure prevailing in the sensor housing (1) acts on the measuring bellows (2). Changes in pressure lead to movements of the measuring bellows (2) which are transmitted via a thrust pin (4) to the connecting bridge (5). The connecting bridge is frictionlessly mounted on hardened points (6). When the pressure rises the connecting bridge (5) moves upwards and operates the microswitch (7). A counter-force is provided by the spring (8), whose pre-tension can be modified by the adjusting screw (9) (switching point adjustment). Turning the setting spindle (9) moves the running nut (10) and modifies the pre-tension of the spring (8). The screw (11) is used to calibrate the microswitch in the factory. The counter pressure spring (12) ensures stable switching behaviour, even at low setting values.

- 1 = Pressure connection
- 2 = Measuring bellows
- 3 = Sensor housing
- 4 = Thrust pin
- 5 = Connecting bridge
- 6 = Pivot points
- 7 = Microswitch or other switching elements
- 8 = Setting spring
- 9 = Setting spindle (switching point adjustment)
- 10 = Running nut (switching point indicator)
- 11 = Microswitch calibration screw (factory calibration)
- 12 = Counter pressure spring

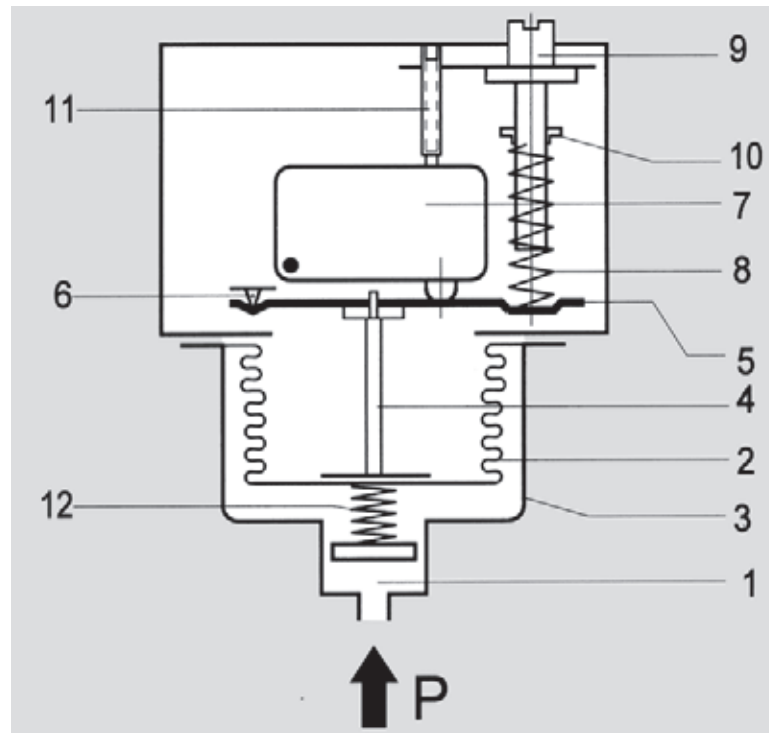

### Pressure sensors

Apart from a few exceptions in the low-pressure range, all pressure sensors have measuring bellows, some made of copper alloy, but the majority of high-quality stainless steel. Measured on the basis of permitted values, the measuring bellows are exposed to a minimal load and perform only a small lifting movement. This results in a long service life with little switching point drift and high operating reliability. Furthermore, the stroke of the bellows is limited by an internal stop so that the forces resulting from the overpressure cannot be transmitted to the switching device. The parts of the sensor in contact with the medium are welded together without filler metals. The sensors contain no seals. Copper bellows, which are used only for low pressure ranges, are soldered to the sensor housing. The sensor housing and all parts of the sensor in contact with the medium can also be made entirely from stainless steel 1.4571 (DNS series). Precise material data can be found in the individual data sheets.

### Pressure connection

The pressure connection on all pressure switches is executed in accordance with DIN 16288 (pressure gauge connection G 1/2A). If desired, the connection can also be made with a G 1/4 internal thread in accordance with ISO 228 Part 1.

Maximum screw-in depth on the G 1/4 internal thread = 9 mm.

### Centring pin

In the case of connection to the G 1/2 external thread with seal in the thread (i.e. without the usual stationary seal on the pressure gauge connection), the accompanying centring pin is not needed. Differential pressure switches have 2 pressure connections (max. and min.), each of which are to be connected to a G 1/4 internal thread.

## Principal technical data

Valid for all pressure switches of the DCM, DNM, DWAM, DWAMV, SDBAM, VCM, VNM, DNM, DWR, DGM, DNS and DDCM series that have a microswitch. The technical data of type tested units may differ slightly (please refer to particular type sheet).

Standard version  
Plug connection



Terminal connection



<b>Switch housing</b>	Die cast aluminium GDAISI 12	Die cast aluminium GDAISI 12
<b>Pressure connection</b>	G 1/2" external thread (pressure gauge connection) and G 1/4" internal thread. 1/4" internal thread for DDCM differential pressure switches	G 1/2" external thread (pressure gauge connection) and G 1/4" internal thread. 1/4" internal thread for DDCM differential pressure switches
<b>Switching function and connection scheme</b> (applies only to version with microswitch)	Floating changeover contact. With rising pressure single pole switching from 3-1 to 3-2.	Floating changeover contact. With rising pressure single pole switching from 3-1 to 3-2.
<b>Switching capacity</b> (for microswitches with a silver contact)	8 A at 250 VAC 5 A at 250 VAC inductive 8 A at 24 VDC 0.3 A at 250 VDC min. 10 mA, 12 VDC	8 A at 250 VAC 5 A at 250 VAC inductive 8 A at 24 VDC 0.3 A at 250 VDC min. 10 mA, 12 VDC
<b>Mounting position</b>	Preferably vertical (see technical data sheet)	Vertical
<b>Protection class</b> (in vertical position)	IP 54	IP 65
<b>Electrical connection</b>	Plug connection	Terminal connection
<b>Cabel entry</b>	Pg 11	M 16 x 1.5
<b>Ambient temperature</b>	-25 to +70 °C (exceptions: DWAM, DWAMV, SDBAM series -20 to +70 °C DGM and FD series: -25 to +60 °C DCM4016, 4025, 1000, VCM4156: -15 to +60 °C)	-25 to +70 °C (exceptions: DWAM, DWAMV, SDBAM series -20 to +70 °C DGM and FD series: -25 to +60 °C DCM4016, 4025, 1000, VCM4156: -15 to +60 °C)
<b>Switching point</b>	Adjustable using the setting spindle	Adjustable using the setting spindle once the switch housing cover is removed
<b>Hysteresis</b>	Adjustable or not adjustable (see Product Summary)	Adjustable or not adjustable (see Product Summary)
<b>Medium temperature</b>	Max. 70 °C, briefly 85 °C	Max. 70 °C, briefly 85 °C
<b>Relative humidity</b>	15 to 95 % (non-condensing)	15 to 95 % (non-condensing)
<b>Vacuum</b>	Higher medium temperatures are possible provided the above limits for the switching device are ensured by suitable measures (e.g. siphon). All pressure switches can operate under vacuum. This will not damage the device (exception DCM1000).	
<b>Repetition accuracy of switching points</b>	< 1 % of the working range (for pressure ranges > 1 bar).	
<b>Vibration resistance</b>	No significant deviations up to 4 g.	
<b>Mechanical durability</b> (pressure sensor)	With sinusoidal pressure application and room temperature, 10 x 10 <sup>6</sup> switching cycles. The expected life depends to a very large extent on the type of pressure application, therefore this figure can serve only as a rough estimate. With pulsating pressure or pressure impacts in hydraulic systems, pressure surge reduction is recommended.	
<b>Electronical durability</b> (microswitch)	100.000 switching cycles at nominal current 8 A, 250 VAC. A reduced contact load increases the number of possible switching cycles.	
<b>Isolation values</b>	Overvoltage category III, contamination class 3, reference surge voltage 4000 V. Conformity to DIN VDE 0110 is confirmed.	
<b>Oil and grease-free</b>	The parts of all pressure switches in contact with the medium are oil and grease free (except the HCD...and DPS...series). The sensors are hermetically sealed and contain no seals (also see ZF1979, special packing).	

## Principal technical data

Valid for all pressure of the DCM, VCM, VNM, DNM, DWR, DGM, DNS, DWAM, DWAMV and DDCM series that have a microswitch. The technical data of type-tested units may differ slightly (please refer to particular type sheet).

Ex-i-version



Ex version (Ex-d)



<b>Switch housing</b>	Die cast aluminium GDAISi 12	Die cast aluminium GDAISi 12
<b>Pressure connection</b>	G 1/2" external thread (pressure gauge connection) and G 1/4" internal thread. 1/4" internal thread for DDCM differential pressure switches	G 1/2" external thread (pressure gauge connection) and G 1/4" internal thread. 1/4" internal thread for DDCM differential pressure switches
<b>Switching function and connection scheme</b> (applies only to version with microswitch)	Floating changeover contact. With rising pressure single pole switching from 3-1 to 3-2	Floating changeover contact. With rising pressure single pole switching from 3-1 to 3-2
<b>Switching capacity</b>	max.: 100mA, 24VDC min.: 2mA, 5VDC	3 A at 250 VAC 2 A at 250 VAC inductive 3 A at 24 VDC 0.1 A at 250 VDC min. 2 mA, 24 VDC
<b>Mounting position</b>	Vertical	Vertical
<b>Protection class</b> (in vertical position)	IP 65	IP 65
<b>Explosion protection Code</b>	Ex II 1/2G Ex ia IIC T6 Ga/Gb Ex II 1/2D Ex ia IIIC T80 °C	Ex II 2G Ex d e IIC T6 Gb Ex II 1/2D Ex ta/tb IIIC T80 °C Da/Db
<b>EC Type Examination Certificate Number</b>	IBExU12ATEX1040	IBExU12ATEX1040
<b>Electrical connection</b>	Terminal connection	Terminal connection
<b>Cabel entry</b>	M 16 x 1.5	M 16 x 1.5
<b>Ambient temperature</b>	-25 to +60 °C (exceptions: DWAM series -20 to +60 °C DGM and FD series: -25 to +60 °C DCM4016, 4025, 1000, VCM4156: -15 to +60 °C)	-20 to +60 °C
<b>Medium temperature</b>	Max. 60 °C	Max. 60 °C
<b>Relative humidity</b>	15 to 95 % (non-condensing)	15 to 95 % (non-condensing)
<b>Switching point</b>	After removing switch housing cover	After removing switch housing cover
<b>Hysteresis</b>	Not adjustable	Not adjustable
<b>Vacuum</b>	Higher medium temperatures are possible provided the above limits for the switching device are ensured by suitable measures (e.g. siphon). All pressure switches can operate under vacuum. This will not damage the device.	
<b>Repetition accuracy of switching points</b>	< 1 % of the working range (for pressure ranges > 1 bar).	
<b>Vibration resistance</b>	No significant deviations up to 4 g.	
<b>Mechanical durability</b> (pressure sensor)	With sinusoidal pressure application and room temperature, 10 x 10 <sup>6</sup> switching cycles. The expected life depends to a very large extent on the type of pressure application, therefore this figure can serve only as a rough estimate. With pulsating pressure or pressure impacts in hydraulic systems, pressure surge reduction is recommended.	
<b>Electronical durability</b> (microswitch)	100.000 switching cycles at nominal current 8 A, 250 VAC. A reduced contact load increases the number of possible switching cycles.	
<b>Isolation values</b>	Overvoltage category III, contamination class 3, reference surge voltage 4000 V. Conformity to DIN VDE 0110 is confirmed.	
<b>Oil and grease-free</b>	The parts of all pressure switches in contact with the medium are oil and grease free (except the HCD...and DPS...series). The sensors are hermetically sealed and contain no seals (also see ZF1979, special packing).	



## Dimensioned drawings of switch housings (mm)

1 Housing 200 (plug connection)

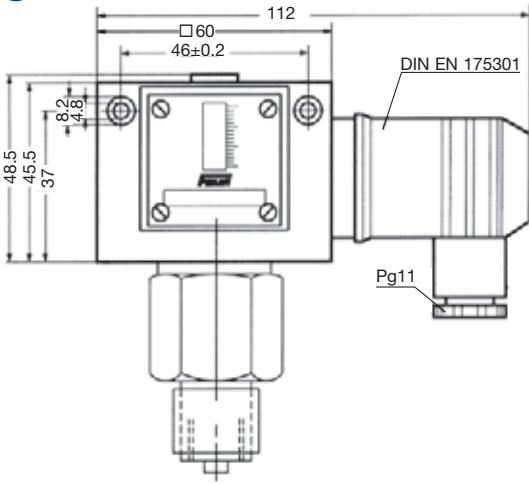

2 Housing 300 (terminal connection)

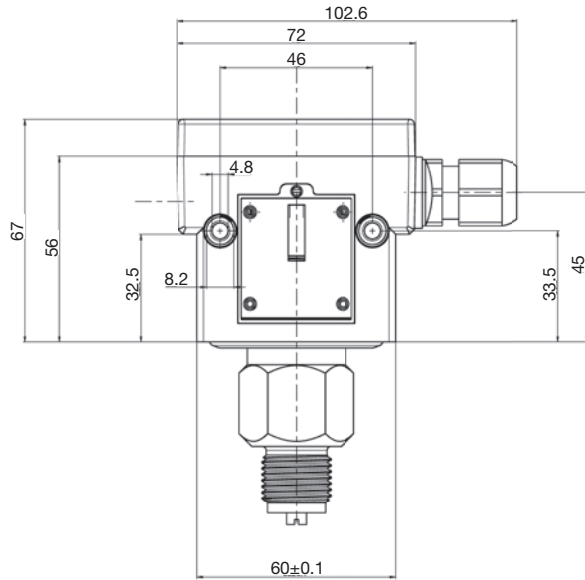

3 Housing 500 (terminal connection Ex-i)

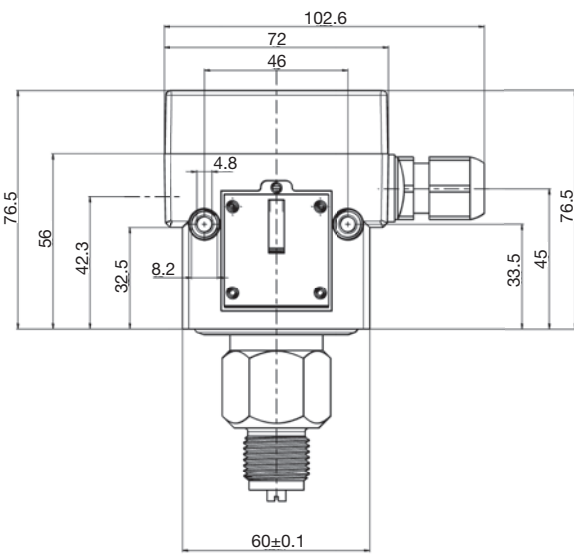

4 Housing 700 (terminal connection Ex-d)

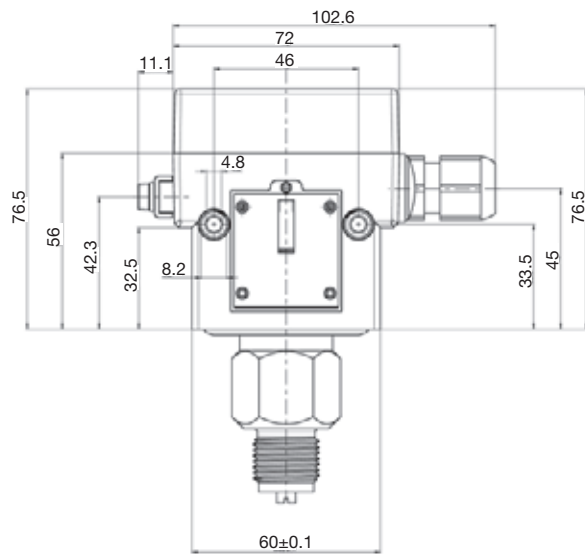

## Dimensioned drawings of pressure sensors (mm)

10

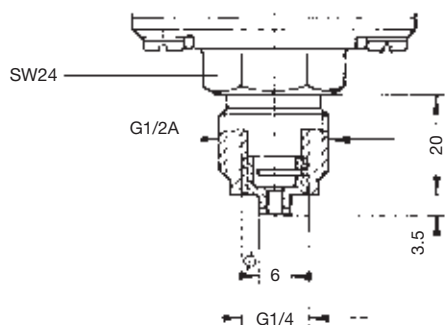

11

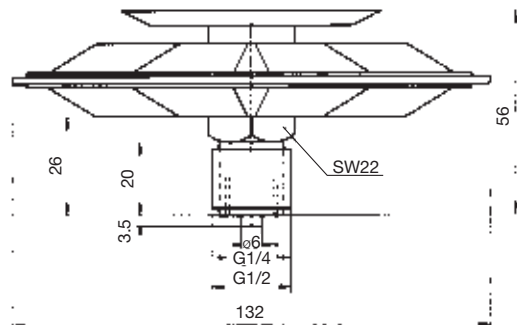

# Dimensioned drawings of pressure sensors (mm)

12

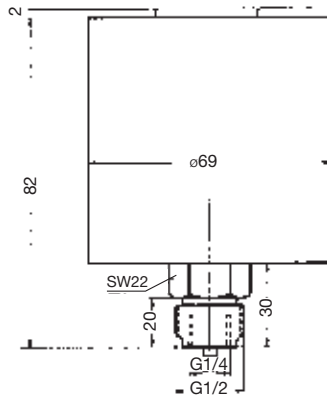

13

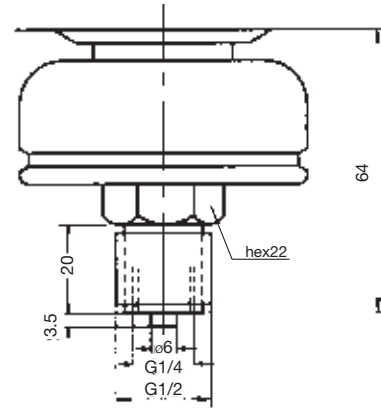

14

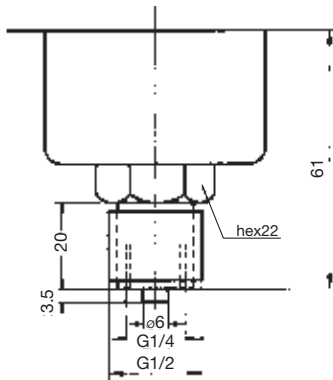

15

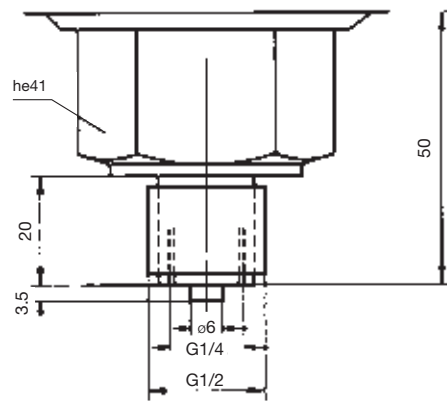

16-19

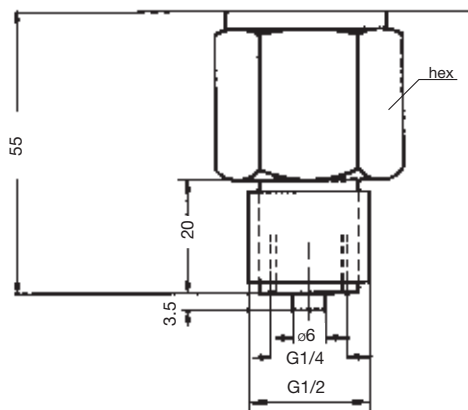

Dimensioned drawing	hex (mm)
16	22
17	24
18	30
19	32

20

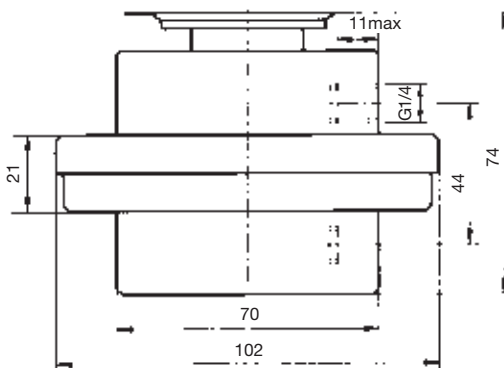

21

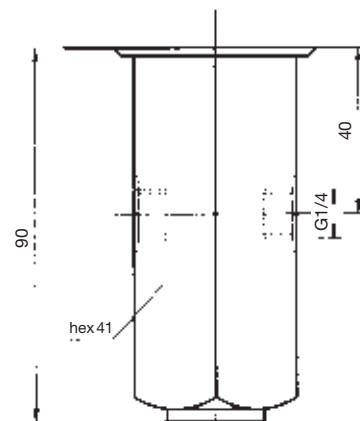

# Setting instructions

## Factory calibration of pressure switches

In view of tolerances in the characteristics of sensors and springs, and due to friction in the switching kinematics, slight discrepancies between the setting value and the switching point are unavoidable. The pressure switches are therefore calibrated in the factory in such a way that the setpoint adjustment and the actual switching pressure correspond as closely as possible in the middle of the range. Possible deviations are equally distributed on both sides.

The device is calibrated either for falling pressure (calibration at lower switching point) or for rising pressure (calibration at higher switching point), depending on the principal application of the type series in question.

Where the pressure switch is used at other than the basic calibration, the actual switching point moves relative to the set switching point by the value of the average switching differential. As FEMA pressure switches have very small switching differentials, the customer can ignore this where the switching pressure is set only roughly. If a very precise switching point is needed, this must be calibrated and checked in accordance with normal practice using a pressure gauge.

### 1. Calibration at lower switching point

Setpoint  $x_s$  corresponds to the lower switching point, the upper switching point  $x_u$  is higher by the amount of the switching differential  $x_d$ .

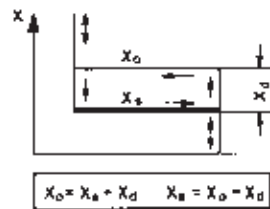

### 2. Calibration at upper switching point

Setpoint  $x_s$  corresponds to the upper switching point, the lower switching point  $x_u$  is lower by the amount of the switching differential  $x_d$ .

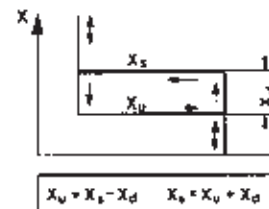

The chosen calibration type is indicated in the technical data for the relevant type series.

## Setting switching pressures

Prior to adjustment, the securing pin above the scale must be loosened by not more than 2 turns and retightened after setting. The switching pressure is set via the spindle. The set switching pressure is shown by the scale.

To set the switching points accurately it is necessary to use a pressure gauge.

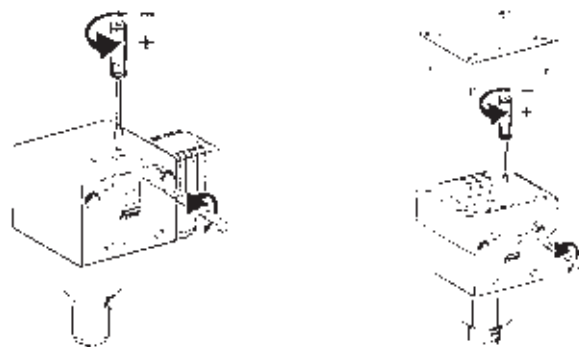

### Changing the switching differential (only for switching device with suffix "V", ZF203)

By means of setscrew within the spindle. The lower switching point is not changed by the differential adjustment; only the upper switching point is shifted by the differential. One turn of the differential screw changes the switching differential by about 1/4 of the total differential range. The switching differential is the hysteresis, i.e. the difference in pressure between the switching point and the reset point.

### Lead sealing of setting spindle (for plug connection housing 200 only)

The setting spindle for setting the desired value and switching differential can be covered and sealed with sealing parts available as accessories (type designation: P2) consisting of a seal plate and capstan screw. The sealing parts may be fitted subsequently. The painted calibration screws are likewise covered.



Clockwise:  
lower switching  
pressure

Anticlockwise:  
higher switching  
pressure

Direction of action of setting spindle

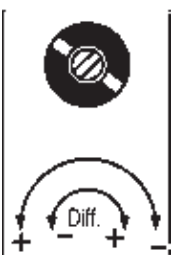

Clockwise:  
greater diffe-  
rence  
Anticlockwise:  
smaller diffe-  
rence

With pressure switches from the DWAMV and DWR...-203 series, the direction of action of the differential screw is reversed.



## Pressure switch with switching state locking (reclosing lock out)

In the case of limiter functions, the switching state must be retained and locked, and it may be unlocked and the system restarted only after the cause of the safety shutdown has been eliminated. There are two ways of doing this:

### 1. Mechanical locking inside the pressure switch

Instead of a microswitch with automatic reset, limiters contain a "bi-stable" microswitch. If the pressure reaches the value set on the scale, the microswitch trips over and remains in this position. The lock can be released by pressing the unlocking button (identified by a red dot on the scale side of the switching device). The lock can operate with rising or falling pressure, depending on the version. **The device can only be unlocked when the pressure has been reduced (or increased) by the amount of the predefined switching differential.** When selecting a pressure limiter, it is necessary to distinguish between maximum and minimum pressure monitoring. Ex-d versions cannot be equipped with internal locking.

#### Maximum pressure limitation

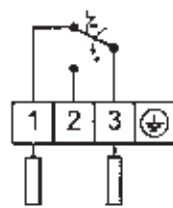

Switching and interlocking with rising pressure. Additional function ZF205.

Connection of control current circuit to terminals 1 and 3.

#### Minimum pressure limitation

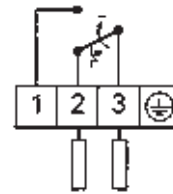

Switching and interlocking with falling pressure. Additional function ZF206.

Connection of control current circuit to terminals 2 and 3.

### 2. External electrical interlock in the control cabinet (suggested circuits)

A pressure monitor (microswitch with automatic reset) can also be used as a limiter if an electrical interlock is added. For pressure limitation in steam and hot water boilers, an external interlock is only permitted if it has been ascertained that the pressure monitor is "of special construction".

#### Maximum pressure limitation with external interlock

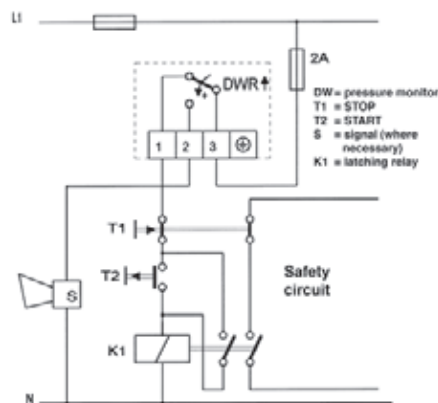

#### Minimum pressure limitation with external interlock

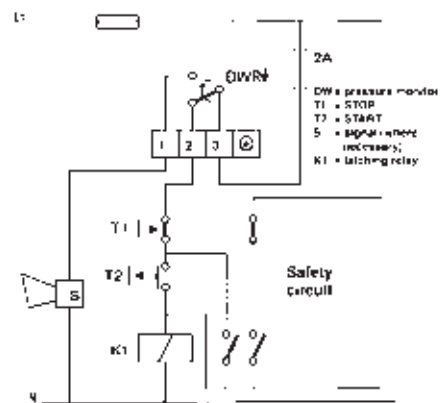

Where the above lock circuit is used, the requirements of DIN 57 116/VDE 0116 are met if the electrical equipment (such as contactors or relays) of the external interlock circuit satisfy VDE 0660 or VDE 0435.

## Explanation of type designations – type codes



The type designations of FEMA pressure switches consist of a combination of letters followed by a number denoting the setting range. Additional functions and version variants are indicated by an extra code which is separated from the basic type by a hyphen. Ex-versions (explosion protection Ex-d) are identified by the prefix "Ex" in front of the type designation.

Basic version (based on the example of DCM series) <b>DCMXXX</b>	With additional function <b>DCMXXX-YYY</b>	Ex-version <b>Ex-DCMXXX</b>
--	---	--------------------------------

DCM	→	Series code (e. g. DCM)
XXX	→	Codes for pressure range
YYY	→	Code for additional function
Ex	→	Code for Ex-version

Switch housing version	
DCMXXX	Basic version with plug connection housing
DCMXXX-2...	Basic version with plug connection housing
DCMXXX-3...	Terminal connection housing (300)
Ex-DCMXXX	Ex-d switching device (700)
DCMXXX-5...	Ex-i version (500)

### Which additional function fits with which pressure switch?

	Plug connection, 200 series  Additional function ZF			Terminal connection, 300/500 series  Additional function ZF				
	203	213	217	301 351	307	513	574 576	575 577
DCM/VCM	• <sup>1</sup>	•	• <sup>1</sup>	•	• <sup>1</sup>	•		
VNM/DNS/VNS	•	•	•	•	•	•		
DWAM		•		•		•	•	•
DDCM		•		•		•		
DWR	•	•		•		•	•	•
DGM		•		•		•	•	•

• available



<sup>1</sup> except DCM4016, DCM4025, VCM4156 and DCM1000

**Combination of several additional functions is not possible!**

**Ex-versions (Ex-d) can only be supplied in basic form.  
Additional functions are not possible.**

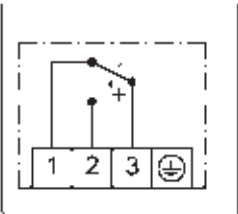
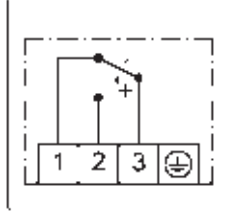
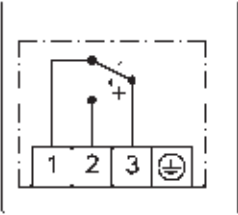
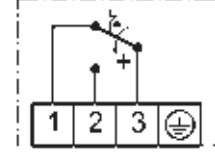
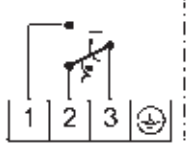

# Pressure switches and pressure monitors

## Additional functions / Connection schemes

	Plug connection, 200 series (IP 54)	Terminal connection, 300 series (IP 65)	Connection scheme
<b>Standard version (plug connection)</b> Micro switch, single pole switching, switching differential not adjustable			
<b>Terminal connection housing (300)</b>		ZF301	
<b>Unit with adjustable switching differential</b>	ZF203		
<b>Maximum pressure limiter with reclosing lockout</b> <b>Interlocking with rising pressure</b> see DWR series	ZF205		
<b>Minimum pressure limiter with reclosing lockout</b> <b>Interlocking with falling pressure</b> see DWR series	ZF206		

### Note to non-available items:

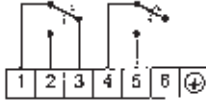
In our article master all the possible technical combinations are not created. Therefore we recommend the previous request for clarification and selection of an alternative solution.

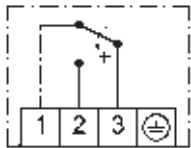
	Plug connection 200 series (IP 54)	Terminal connection 300 series (IP 65)	Connection scheme	
<p><b>Two micro switches</b>, switching in parallel or in succession. Fixed switching differential, only possible with terminal connection housing.</p> <p><b>State the switching differential</b> (not possible with all pressure switches).</p>		ZF307		
<p><b>Two micro switches, 1 plug</b> switching in succession, no adjustable switching differential.</p> <p><b>State the switching scheme *</b> (not possible with all pressure switches).</p>	ZF217 *		 <p>Connection scheme selection, see page 36</p>	
<p><b>Gold-plated silver contact</b>, single pole switching (not available with adjustable switching differential).</p> <p><b>Switching capacity:</b> max. 24 VDC, 100 mA, min. 5 VDC, 2 mA</p>	ZF213			
<p><b>Switch housing with surface protection</b> (chemical version)</p>		ZF351		

**Note to non-available items:**

In our article master all the possible technical combinations are not created. Therefore we recommend the previous request for clarification and selection of an alternative solution.

\* Connection schemes for switching schemes, see page 36.  
Please state interval when ordering!  
Example for ordering: DCM10-217A-S.  
Additional text: switching scheme A4

**Example for ordering:**

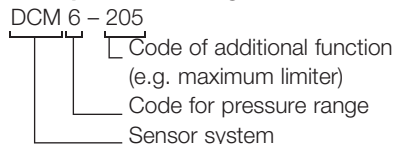

**How to order:**

Pressure switch  
DCM6-205  
or DCM6 with ZF205

# Pressure switches and pressure monitors

## Additional functions for Ex-i-equipment



DWAM6-576

- Housing (500) with terminal connection (IP 65), "blue" cable entry and terminals.
- Also available with resistor combination for line break and short-circuit monitoring (with isolating amplifier).

### ! Important:

All pressure switches with the ZF5... additional functions listed here can only be operated in combination with a suitable isolating amplifier.

### i Additional information:

Our pressure switches and thermostats are considered to be "simple electrical equipment" within the meaning of standard EN60079-11:2007. Testing is not mandatory for this type of equipment.

### i ATEX-Certificate: please see page 10–13

#### Additional functions for Ex-equipment

Ex II 1/2G Ex ia IIC T6 Ga/Gb

Ex II 1/2D Ex ia IIIC T80 °C

#### Connection scheme

#### Gold plated contact

single pole switching, fixed hysteresis,  
not adjustable

#### Switching capacity:

max. 24 VDC, 100 mA, min. 5 VDC, 2 mA

#### For the power supply circuit:

$U_i$  24 V DC       $C_i$  1 nF

$I_i$  100 mA       $L_i$  100  $\mu$ H

#### ZF513

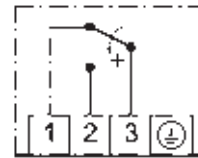

Versions with resistor combination for line break and short-circuit monitoring in control current circuit, see DBS series, pages 54–56:

#### For the power supply circuit:

$U_i$  14 V DC

$R_i$  1500 Ohm

$C_i$  1 nF

$L_i$  100  $\mu$ H

Normally closed contact with resistor combination, for **minimum pressure monitoring**, gold plated contact, plastic-coated housing (chemical version).

#### ZF574

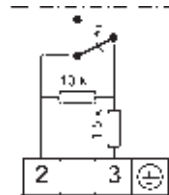

Normally closed contact **with reclosing lockout** and resistor combination, for **minimum pressure monitoring**, plastic coated housing (chemical version).

#### ZF575

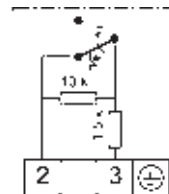

see

DBS series

pages 54–56

Normally closed contact with resistor combination, for **maximum pressure monitoring**, gold plated contact, plastic coated housing (chemical version).

#### ZF576

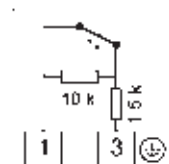

Normally closed contact **with reclosing lockout** and resistor combination, for **maximum pressure monitoring**, plastic-coated housing (chemical version).

#### ZF577

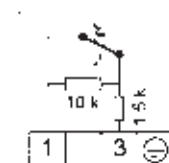

#### Note to non available items:

In our article master all the possible technical combinations are not created. Therefore we recommend the previous request for clarification and selection of an alternative solution.



## Service functions

Devices with service functions will be produced according to the customer's specifications.

The system requires that these product combinations are identified in such a way as to prevent any possibility of confusion. These combinations are characterised by a product code with the suffix "-S" on the packaging label as well as separate labels with barcodes for each service function.

Service functions	Plug connection	Terminal connection	Ex-i /
	200 series	300 series	Ex-d
<b>Adjustment according to customer's instruction:</b>			
- one switching point	ZF1970*	ZF1970*	ZF1970*
- two switching points or defined switching differential	ZF1972*	ZF1972*	-
<b>Adjustment and lead sealing according to customer's instruction:</b>			
- one switching point	ZF1971*	- -	
- two switching points or defined switching differential	ZF1973*	- -	
Labelling of units according to customer's instruction with sticker	ZF1978	ZF1978	ZF1978
Special packing for oil and grease-free storage	ZF1979	ZF1979	ZF1979
<b>Test reports according to EN 10 204</b>			
- Certificate 2.2 based on non specific specimen test	WZ2.2	WZ2.2	WZ2.2
- Inspection test certificate 3.1 based on specific test	AZ3.1B1	AZ3.1B1	AZ3.1B1
- Inspection test certificate for FV separating diaphragms	AZ3.1-V	AZ3.1-V	AZ3.1-V

\* **Switching point adjustment:** Please specify **switching point and direction of action** (rising or falling pressure).

Service functions are available for the following type series (including Ex-versions):

Pressure switches: DCM, DNM, DNS, VNS, VCM, VNM, DDCM, DWR, DWAM, DWAMV, SDBAM, DGM, FD

### Ordering devices with service functions

#### Example:

Ordering 1 DCM6, set at 4 bar rising, identified with code PSH008 as requested by the customer and acceptance test certificate 3.1.

The order confirmation contains:

- 1 DCM6-S ("S" is need for factory = following lines belong to this item)
- 1 ZF1970: set to 4 bar rising
- 1 ZF1978: PSH008
- 1 AZ3.1B1

Included items: Labels with barcodes on the packaging:  
DCM6-S  
ZF1970: set to 4 bar rising  
ZF1978: PSH008  
AZ3.1B1

Pack contents: 1 DCM6 (without "S" suffix) marked  
1 ZF1970: set to 4 bar rising  
1 ZF1978: PSH008  
1 AZ3.1 B1 will be sent by extra post  
1 Installation and operating instructions

## S2 type series

### Examples of use for two stage pressure switches

Pressure monitoring and controlling can be greatly simplified by using pressure monitors with two built-in microswitches which can be made to operate one after the other under rising or falling pressure. For example, minimum and maximum pressure monitoring can be achieved with only **one** pressure switch, doing away with the need for a second pressure switch (including the cost of installation). Step switching, e.g. pressure-dependent control of a two-stage pump, is of course also possible using this special series.

#### For pressure dependent control of automatic expansion valves and pressure holding devices

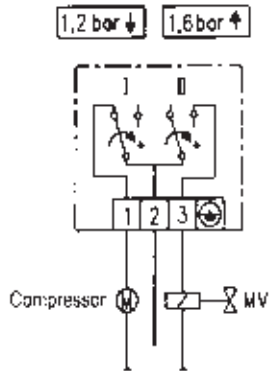

#### Example 1:

##### Requirement

Pressure holding devices and automatic expansion valves usually have a gas cushion whose pressure must be kept constant within a certain range. If the pressure is too low, a compressor is switched on. If the pressure is too high, a solenoid valve must be opened to vent the gas. Between these two levels is a neutral zone, in which the compressor and the solenoid valve are at rest.

##### Solution

All pressure switches of types DCM, DNS, each with additional function ZF217 and switching scheme A 2, are suitable. All pressure ranges listed in the technical documents are possible. Example for ordering: see page 24

##### Switching function / connection scheme

Switch I: With falling pressure, contact 1–2 closes (compressor on)  
With rising pressure, contact 1–2 opens (compressor off)

Switch II: With rising pressure, contact 2–3 closes (valve open)  
With falling pressure, contact 2–3 opens (valve closed).  
In between there is a neutral zone in which the compressor is not switched on and the solenoid coil is not energized (off position).

#### Minimum and maximum pressure monitoring in a nitrogen line

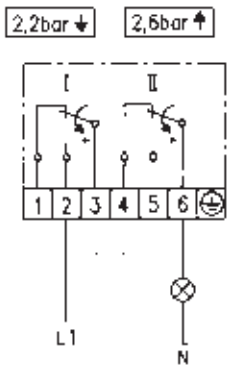

#### Example 2:

##### Requirement

In a process engineering system, the pressure in a nitrogen line has to be monitored. A green signal lamp indicates that the pressure in the line is between 2.2 and 2.6 bar. If the pressure goes below 2.2 bar or above 2.6 bar, the indicator lamp goes out and the system shuts down.

##### Solution

The first contact of a DCM3–307 pressure switch with 2 microswitches opens under falling pressure at 2.2 bar; the second microswitch opens under rising pressure at 2.6 bar. If the pressure is >2.2 bar or <2.6 bar, the circuit is closed via both microswitches and the signal lamp is lit.

## S2 type series

### Pressure switches with 2 microswitches - technical data

FEMA pressure switches of the **DCM** (except DCM1000, DCM4016 and DCM4025), **VCM** (except VCM4156), **VNM, DNS, VNS** series can be equipped with 2 microswitches.

**This is not possible with any other type series or with Ex-versions.**

#### Technical data

##### Standard equipment

The standard equipment of every two stage pressure switch includes a switching device with 2 microswitches, both single pole switching. Switch I monitors the low pressure, switch II the higher pressure. The setting ranges indicated in the data sheets for the basic types apply to the two stage pressure switches as well. It should be noted that the switching differentials of the individual microswitches may not be exactly the same due to component tolerances.

##### Switching difference (see table, page 35)

The switching interval of the two microswitches is the difference (in bar or mbar) between the switching points of the two micro switches.

##### Example for ZF307:

When the pressure rises (e.g. 2.8 bar), a two stage pressure switch turns on a warning light, and if the pressure continues to rise (e.g. 3.2 bar) the system shuts down. The switching interval is  $3.2 - 2.8 = 0.4$  bar. The following applies to all versions:

The switching interval remains constant over the whole setting range of the pressure switch. If the switching pressure setting is changed with the setting spindle, the switching interval does not change - the switching points are moved in parallel.

##### Switching differential (see table page 35)

The switching differential, i.e. the hysteresis of the individual micro switches, corresponds to the values of the relevant basic version referred to in the Product summary. In the case of two stage pressure switches, **the switching differential of the individual micro switches is not adjustable.**

##### Versions

Two stage pressure switches are available in three different versions, each identified by a ZF number. The versions differ in terms of their connection schemes and electrical connection types (terminal or plug connection).

The applicable data sheet for the basic types contains the technical data for the two stage pressure switches. This includes all limits of use, such as temperature, maximum pressure, mounting position, protection class, electrical data etc. The principal dimensions are the same as for single-stage pressure switches with comparable pressure ranges and design features.

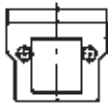
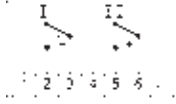
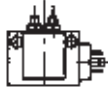
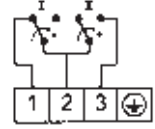
Additional function	Switching difference between the two micro switches	Electrical connection	Connection diagram	Ordering information required
<b>ZF307</b> 	<b>Factory setting</b> according to customer's instruction Switching difference fixed	<b>Terminal connection</b> (All terminals of both microswitches are accessible (6 terminals))	2 x single pole switching 	1. Basic type with ZF 307 2. Switching points I and II, with direction of action in each case (rising or falling pressure) Example: DCM16-307 Switching point I: 10 bar falling Switching point II: 12 bar falling or switching interval only.
<b>ZF217</b> 	<b>Adjustable</b> via adjustment knobs I and II in accordance with "Switching difference" table	<b>Plug connection</b> in accordance with DIN EN175301 (3-prong + earth conductor) Function-appropriate internal wiring in accordance with "Switching functions" table	Example selection in accordance with "Switching schemes" table, page 36. 	1. Basic type with ZF217 2. <b>Switching scheme</b> For example: DCM16-217/B 4 Since all values are adjustable within the specified limits, no further data is required.

#### Note on ordering additional function ZF217

Switching scheme	Switching device	Ordering position	Additional text
A1	A	DCM6-217A-S	Switching scheme A1
A2	C	DCM6-217C-S	Switching scheme A2
A3	C	DCM6-217C-S	Switching scheme A3
A4	A	DCM6-217A-S	Switching scheme A4
B1	B	DCM6-217B-S	Switching scheme B1
B2	D	DCM6-217D-S	Switching scheme B2
B3	D	DCM6-217D-S	Switching scheme B3
B4	B	DCM6-217B-S	Switching scheme B4
C1	B	DCM6-217B-S	Switching scheme C1
C2	D	DCM6-217D-S	Switching scheme C2
C3	D	DCM6-217D-S	Switching scheme C3
C4	B	DCM6-217B-S	Switching scheme C4
D1	A	DCM6-217A-S	Switching scheme D1
D2	C	DCM6-217C-S	Switching scheme D2
D3	C	DCM6-217C-S	Switching scheme D3
D4	A	DCM6-217A-S	Switching scheme D4

## S2 type series (selection)

ZF217 pressure switches with two microswitches and switching difference

### Switching difference of two stage pressure switches (ZF217, ZF307)

Type series S2 ZF217 ZF307	 Higher pressure      Lower pressure			
	min. switching difference (ZF217)	max. switching difference (mean values) ZF217, ZF307		
Type	Factory default (parallel) ZF307	switching scheme A1/A3/B2/B4 C1/C3/D2/D4 + ZF 307	switching scheme A2/A4/C2/C4	switching scheme B1/B3/D1/D3
DCM06	40 mbar	165 mbar	190 mbar	140 mbar
DCM025	20 mbar	140 mbar	160 mbar	120 mbar
DCM1	40 mbar	240 mbar	280 mbar	200 mbar
DCM3, DNS3-201	0,1 bar	0,65 bar	0,75 bar	0,55 bar
DCM6, DNS6-201	0,15 bar	0,95 bar	1,2 bar	0,8 bar
DCM10, DNS10-201	0,25 bar	1,6 bar	1,85 bar	1,35 bar
DCM16, DNS16-201	0,3 bar	2,0 bar	2,3 bar	1,7 bar
DCM25	0,6 bar	4,0 bar	4,6 bar	3,4 bar
DCM40	0,9 bar	6,0 bar	6,9 bar	5,1 bar
DCM63	1,3 bar	8,5 bar	9,8 bar	7,2 bar
DNM025, DNS025-201	35 mbar	215 mbar	240 mbar	180 mbar
VCM095	40 mbar	300 mbar	340 mbar	260 mbar
VCM101	40 mbar	260 mbar	300 mbar	220 mbar
VCM301	20 mbar	100 mbar	120 mbar	80 mbar
VNM111, VNSM111-201	50 mbar	310 mbar	360 mbar	260 mbar

### Switching devices with adjustable switching difference

#### Additional function ZF217

On switching devices with additional function ZF217, the switching difference is continuously adjustable via two adjustment knobs I and II accessible from outside. The maximum possible switching difference is stated in the "Switching difference" table.

Turning adjustment knob I clockwise produces a lower switching point for microswitch I

Turning adjustment knob II anticlockwise produces a higher switching point for microswitch II

Adjustment knobs I and II have an internal stop to prevent the micro switches from being adjusted beyond the effective range.

Adding together the adjustments on knobs I and II results in the switching difference between the two micro switches. Changes made with the setting spindle do not affect the switching difference. The switching difference remains constant over the whole setting range of the spindle. The two switching points are moved up or down in parallel.

#### Recommended adjustment method for switching devices with ZF217

- Set adjustment knobs I and II to their basic positions.  
Turn adjustment knob I anticlockwise as far as possible.  
Turn adjustment knob II clockwise as far as possible.
- Adjust the setting spindle **S** by the scale to a value midway between the desired upper and lower switching points.
- With pressure applied, set the lower switching point with adjustment knob I.
- In the same way as in step 3, set the upper switching point with adjustment knob II.
- If the desired upper and lower switching points cannot be reached, turn the setting spindle **S** in the appropriate direction and repeat steps 3 and 4.

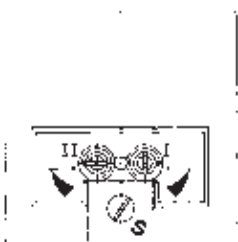

# S2 type series

## Two stage pressure switches, switching schemes for ZF217

Function appropriate internal configuration of microswitches I and II, switching scheme selection table. The switch position shown corresponds to the pressureless state. On the horizontal axis is the switching function of microswitch I (A-D); on the vertical axis is the switching function of microswitch II (1-4). At the intersection is the switching scheme which satisfies both conditions (e.g. A 2).

		Microswitch I (lower switching point)			
		A falling, close	B rising, close	C falling, open	D rising, open
Microswitch II (upper switching point)	1 falling, close				
	2 rising, close				
	3 falling, open				
	4 rising, open				

**Information required when ordering:**

As well as the basic type (e.g. DCM10) and the switching scheme (e.g. A 2), for factory setting it is also necessary to indicate the switching points and direction of action:

Example: DCM10-217C-S, switching scheme: A2, Switch I: 6.5 bar falling, Switch II: 7.5 bar rising.