

S6065

Series S6065

Flow monitoring for liquid media

The flow monitors tested (according to notice "Flow 100") of series S6065A are particularly suitable for flow monitoring of coolants in

air-conditioning and refrigeration systems. Version V4A is also suitable for monitoring aggressive liquids.

Technical data

Switching capacity 15 (8) A, 24...250 VAC

Service life

50000 cycles at nominal load

Working temperature -40°C...+85°C

Electrical connection

Screw terminals for 1.5 mm²

Cable diameter 6...9 mm

Protection class I according to EN60730

Protection class IP65 according to EN60529

Housing material

ABS and corrosion-protected steel

Product characteristics

- Low-cost solution for flow monitoring in heating, ventilation and air-conditioning installations
- Fully encapsulated microswitch (single-pole changeover contact) with high current capacity
- Tested according to notice "Flow 100"

Switching point adjustment

The unit is preset to the lowest switching range. The desired switching range can be set by turning the adjusting screw in a clockwise direction (in the area of the connection terminals). Table of switching values 1 shows reset points (RP), switching points (SP) and paddle sizes for different pipe diameters.

Mounting

Flow monitors for liquid media S6065A1003 and S6065A2001 can be mounted in any position, but must be positioned far enough away from pipe angles, filters and valves. The arrow on the housing must point in the flow direction. When installing in vertical pipes, take care to ensure that the flow direction is from bottom to top. Readjustment of the switching point is also necessary, as the weight of the paddle in this position affects the cut-off range. To protect the internal bellow against dirt deposits, the unit must never be installed in the pipe with the housing pointing downwards.

Replacement paddle: PA2

Unit specifications

Models	S6065A1003	S6065A2001
Flow medium	non-aggressive liquids	aggressive liquids
Mounting	Rp 1" (ISO 7/1)	Rp 1" (ISO 7/1)
Max. temperature of medium	120°C	120°C
Pressure	11 bar	30 bar
Sensor housing material	Brass	1.4404
Paddle material	1.4401	1.4401
Paddle lever material	Brass	1.4401
Housing dimensions	113 x 70 x 65 mm	113 x 70 x 65 mm
Weight	850 g	850 g
Approvals	Flow 100	Flow 100
Replacement paddle, stainless steel PA2		

Table of switching values 1

Pipe DN	Length of paddle	Reset and switching points (m ³ /h)			
		min. flow rate		max. flow rate.	
		RP	SP	RP	SP
1"	1"	0.6	1.0	2.0	2.1
1 1/4"	1"	0.8	1.3	2.8	3.0
1 1/2"	1"	1.1	1.7	3.7	4.0
2"	1" + 2"	2.2	3.1	5.7	6.1
2 1/2"	1" + 2"	2.7	4.0	6.5	7.0
3"	1" + 2" + 3"	4.3	6.2	10.7	11.4
4"	1" + 2" + 3"	11.4	14.7	27.7	29.0
4"	1" + 2" + 3" + Z*	6.1	8.0	17.3	18.4
5"	1" + 2" + 3"	22.9	28.4	53.3	55.6
5"	1" + 2" + 3" + Z*	9.3	12.9	25.2	26.8
6"	1" + 2" + 3"	35.9	43.1	81.7	85.1
6"	1" + 2" + 3" + Z*	12.3	16.8	30.6	32.7
8"	1" + 2" + 3"	72.6	85.1	165.7	172.5
8"	1" + 2" + 3" + Z*	38.6	46.5	90.8	94.2

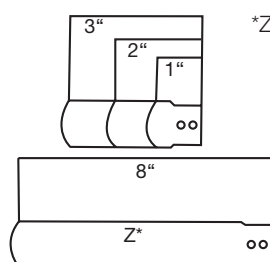

*Z: 8" paddle must be shortened according to the pipe diameter. The installed paddle must not touch the pipe walls.

Wiring diagram:

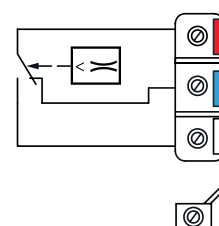

At falling flow switching from red – white to red – blue at rising flow switching from red – blue to red – white.

Series S6065/SLF15/SWF62/SWF62L

S6065A1003 / S6065A2001

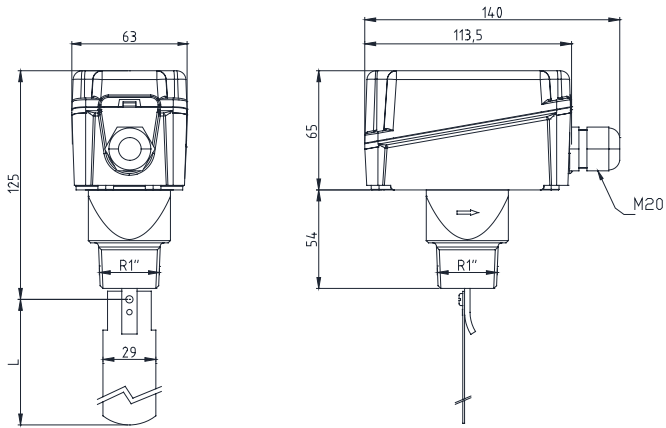

SLF15

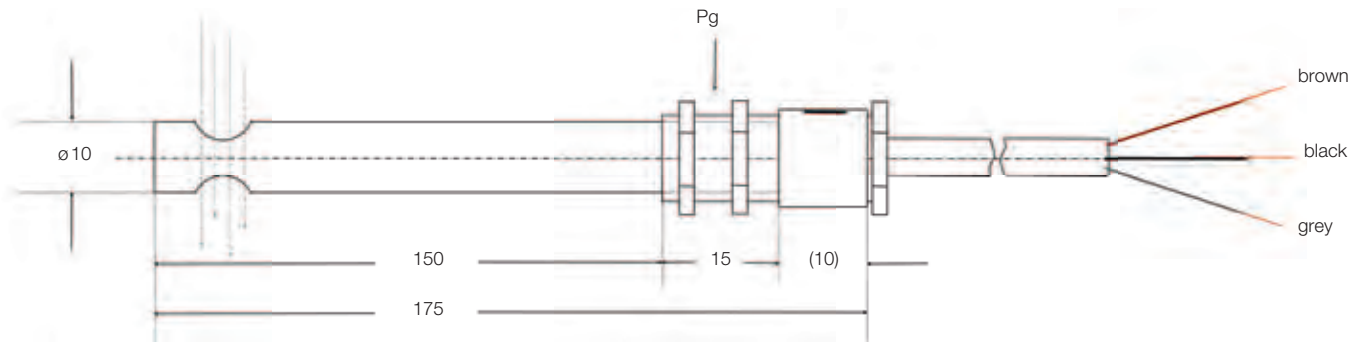

SWF62

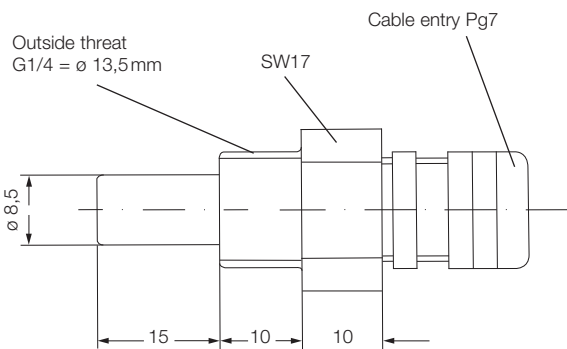

SWF62L

