



HSA⊕ Filter Housing

- sanitary air / gas

- Sanitary range of air / gas housing
- Available in 4 different housing classes: Atex, CE, High Pressure and Oxygen Service
- Both beverage and pharmaceutical surface finishes available
- A choice of easy to use sanitary vent and drain options



Specification

Materials of Construction

- Housing: 316L Stainless Steel
- Seals: EPDM FDA
PTFE FDA
Silicone FDA
Viton FDA

Surface Finish

- Beverage Finish
 - Internal: Polished 0.4 µm Ra
 - External: Polished 0.25 µm Ra
- Pharmaceutical Finish
 - Internal: Polished 0.4 µm Ra and Electropolished
 - External: Polished 0.25 µm Ra

Welding

All assembly welds are full penetration. All welds are crevice and undercut free. Weld finish & detail drawings available upon request.

Design Code

Housings designed in accordance with the European Council Pressure Equipment Directive (PED) 97/23/EC and the UK statutory Pressure Equipment Regulations (PER) 1999 N° 2001.

Design Basis

ASME VIII Division 1.
ATEX 94/9/EC (where applicable)

ATEX Working Condition PED 97/23/EC			Maximum Pressure				
Fluid Group	State	Temperature	01K	011	012	013	014
Non Dangerous	Gas / Vapour	135 °C [275 °F]	10.00 barg (145.03 psig)	10.00 barg (145.03 psig)	10.00 barg (145.03 psig)	10.00 barg (145.03 psig)	10.00 barg (145.03 psig)
Dangerous	Gas / Vapour	135 °C [275 °F]	8.00 barg (116.03 psig)	8.00 barg (116.03 psig)	8.00 barg (116.03 psig)	7.20 barg (104.42 psig)	5.60 barg (81.22 psig)
PED Conformity Assessment Category			SEP	SEP	CAT I	CAT I	CAT I
Volume (litres)			1.9	3.1	5.0	6.9	8.8

CE Working Condition PED 97/23/EC			Maximum Pressure				
Fluid Group	State	Temperature	01K	011	012	013	014
Non Dangerous	Gas / Vapour	150 °C [302 °F]	10.00 barg (145.03 psig)	10.00 barg (145.03 psig)	10.00 barg (145.03 psig)	10.00 barg (145.03 psig)	10.00 barg (145.03 psig)
Dangerous	Gas / Vapour	150 °C [302 °F]	8.00 barg (116.03 psig)	8.00 barg (116.03 psig)	8.00 barg (116.03 psig)	7.20 barg (104.42 psig)	5.60 barg (81.22 psig)
PED Conformity Assessment Category			SEP	SEP	CAT I	CAT I	CAT I
Volume (litres)			1.9	3.1	5.0	6.9	8.8

High Pressure Working Condition PED 97/23/EC			Maximum Pressure				
Fluid Group	State	Temperature	01K	011	012	013	014
Non Dangerous	Gas / Vapour	205 °C [401 °F]	16.00 barg (232.06 psig)	16.00 barg (232.06 psig)	16.00 barg (232.06 psig)	16.00 barg (232.06 psig)	16.00 barg (232.06 psig)
PED Conformity Assessment Category			SEP	SEP	CAT I	CAT I	CAT I
Volume (litres)			1.9	3.1	5.0	6.9	8.8

Oxygen Service Working Condition PED 97/23/EC			Maximum Pressure				
Fluid Group	State	Temperature	01K	011	012	013	014
Dangerous	Gas / Vapour	150 °C [302 °F]	8.00 barg (116.03 psig)	8.00 barg (116.03 psig)	8.00 barg (116.03 psig)	7.20 barg (104.42 psig)	5.60 barg (81.22 psig)
PED Conformity Assessment Category			SEP	SEP	CAT I	CAT I	CAT I
Volume (litres)			1.9	3.1	5.0	6.9	8.8

Physical Characteristics

Bowl Height	Dimensions (mm)	Dimensions (mm)			Typical Weight (Kg)		
		'A'	'B'	'C'	Bowl	Head	Total
5" (125 mm)	229 337 205	0.9	1.9	3.3			
10" (250 mm)	229 487 324	1.5	1.9	3.9			
20" (500 mm)	229 737 572	2.5	1.9	4.9			
30" (750 mm)	229 982 820	3.5	1.9	5.9			
40" (1000 mm)	229 1232 1068	4.5	1.9	6.9			

Dimensions shown are for a vessel with 2" tri-clamp ports, sample port and drain valve. For other formats, please contact Parker domnick hunter.

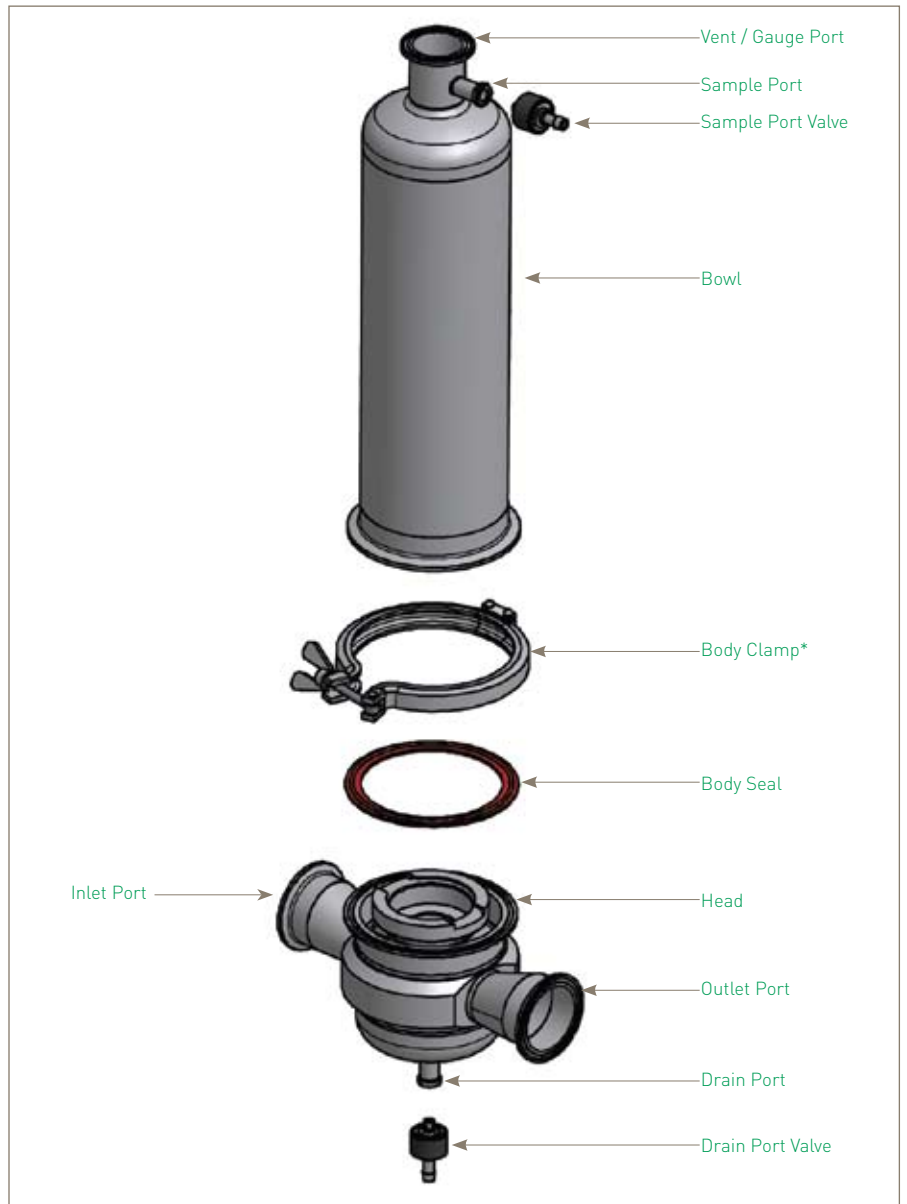
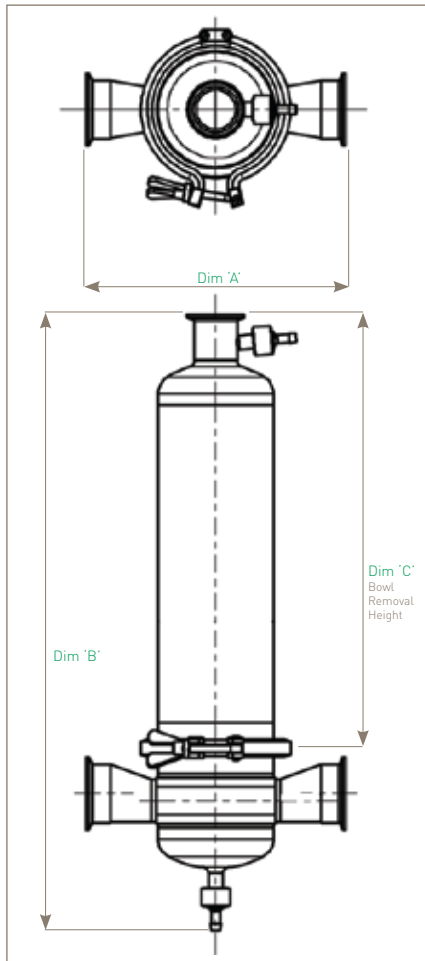

*Double bolted clamp required for HP and PTFE seal options

Ordering Information



Code Vessel Class		Code Length (Nominal)		Code Connection Size		Code Standard		Code Cartridge		Code Seal		Code Vent		Code Drain	
AT	ATEX	K	5" (125 mm)	Y	1 1/2" (38.1 mm)	T	Tri-Clamp	C	226	E	EPDM	C	Rectus 21 Vertical	H	Hosebarb
CE	Standard	1	10" (250 mm)	C	2" (50.8 mm)					P*	PTFE	H	1 1/2" TCF & Hosebarb	R	Rectus 21
HP*	High Pressure	2	20" (500 mm)							S	Silicone	I	1 1/2" TCF & Staubli RBE03	S	Staubli RBE03
OX	Oxygen Service	3	30" (750 mm)							V	Viton	M	1 1/2" TCF & 1/2" TCF	T	RBE03
		4	40" (1000 mm)									R	1 1/2" TCF & Rectus 21		1/2" TCF
												S	Staubli RBE03 Vertical		
												T	1 1/2" TCF Only		

* Supplied complete with a double bolted clamp

* Double bolted clamp required

Code Surface Finish		Internal	External
B	Beverage	0.4 µm	0.25 µm
P	Pharmaceutical	0.4 µm EP	0.25 µm

Code Tagged	
T	Yes
X	No

For Tagged Options customer identification numbers required at time of ordering

Parker domnick hunter has a continuous policy of product development and although the Company reserves the right to change specifications, it attempts to keep customers informed of any alterations. This publication is for general information only and customers are requested to contact our Process Filtration Sales Department for detailed information and advice on a products suitability for specific applications. All products are sold subject to the company's Standard conditions of sale.